

# Grinding efficiency improvement of hydraulic cylinders parts for mining equipment

*Aleksandr Korotkov*<sup>1,\*</sup>, *Vitaliy Korotkov*<sup>1</sup>, *Leonid Mametyev*<sup>2</sup>, *Lidia Korotkova*<sup>1</sup> and *Tatiana Terjaeva*<sup>3</sup>

<sup>1</sup>T.F. Gorbachev Kuzbass State Technical University, Department of Metal-cutting machines and tools, 28 Vesennya st., Kemerovo, Russian Federation, 650000

<sup>2</sup>T.F. Gorbachev Kuzbass State Technical University, Department of Mining machines and complexes, 28 Vesennya st., Kemerovo, Russian Federation, 650000

<sup>3</sup>T.F. Gorbachev Kuzbass State Technical University, Department of Coal, Engineering Plastics and Environmental Protection, 28 Vesennya st., Kemerovo, Russian Federation, 650000

**Abstract.** The aim of the article is to find out ways to improve parts treatment and components of mining equipment on the example of hydraulic cylinders parts, used as pillars for mine roof supports, and other actuator mechanisms. In the course of the research work methods of machine retaining devices design were used, the scientific approaches for the selection of progressive grinding schemes were applied; theoretical and practical experience in the design and production of new constructions of grinding tools was used. As a result of this work it became possible to create a progressive construction of a machine retaining device for grinding of large parts of hydraulic cylinders, to apply an effective scheme of rotary abrasive treatment, to create and implement new design of grinding tools by means of grains with controllable shape and orientation. Implementation of the results obtained in practice will improve the quality and performance of repairing and manufacturing of mining equipment.

## 1 Introduction

Hydraulic cylinders are widely used in mining industry as hydraulic pillars for mine roof supports, as well as actuators for different mining equipments. Hard working conditions of hydraulic cylinders (heavy loads, high humidity, coal dust, and coal and rock fragments as active abrasive elements) lead to their intensive wear, damage or malfunction.

As a result, a problem of repairing often occurs, reconstruction of individual parts of cylinders or their complete replacement. As half of the main components of the hydraulic cylinder is made with high accuracy and low surface roughness and it has a "mirrored" surface, so parts treatment is closely connected with grinding and with grinding tools.

Analysis of ways to enhance the effectiveness of the grinding process of essential parts of hydraulic cylinders shows that there are significant and vacant reserves of potential opportunities in this problem [1]. They can be divided into two groups – technological ways to improve grinding efficiency and instrumental ones. The first group includes the

---

\* Corresponding author: [korotkov.a.n@mail.ru](mailto:korotkov.a.n@mail.ru)

development of advanced methods of grinding and construction of machine tools for their implementation. The second group includes design, manufacture and application of new high-performance constructions of grinding tools.

## 2 Materials and Methods

When plunger of hydraulic cylinders is being grinding, having large dimension (length and diameter, respectively, over 1000 mm and 400 mm) and weight, there is a problem with their run-out during rotation in the centers of a machine cutting tool (turning or grinding tool). Elimination of these run-outs, reaching  $\Delta = 5 \div 10$  mm per side by means of mobile or stationary lunettes, does not always produce the desired effect – outruns are reduced but are not completely eliminated. Such situation becomes dangerous when plungers (or rods) are treated when a grinding disk is used as a grinding tool and a work piece is treated by a scheme of cylindrical grinding. If there are great run-outs a disk may fail during operation due to irregular allowance and large cyclic loads, and a part can get waste of the grinding surface.

Removal of such negative consequences under grinding is achieved by implementing of quite costly measures – increasing the fixity of the machine construction (for example, through the purchase of a new machine), which is under repairing is not quite cost-effective, or it can be done due to the replacement of tools and grinding scheme [2, 3, 4, 5]. Thus often under run-outs of machine parts, hard grinding disk is replaced by a grinding belt or a flap grinding disk, and the cylindrical grinding scheme is changed into the scheme of belt and flap grinding [6,7]. However, in this case, there is a disadvantage in treatment performance and increased consumption of tools, which are rapidly worn.

As an alternative variant of treatment of mentioned machine parts the KuzSTU department of "Metal-cutting machines and tools" proposed grinding with the help of a developed machine tool, which is schematically shown in Fig. 1.

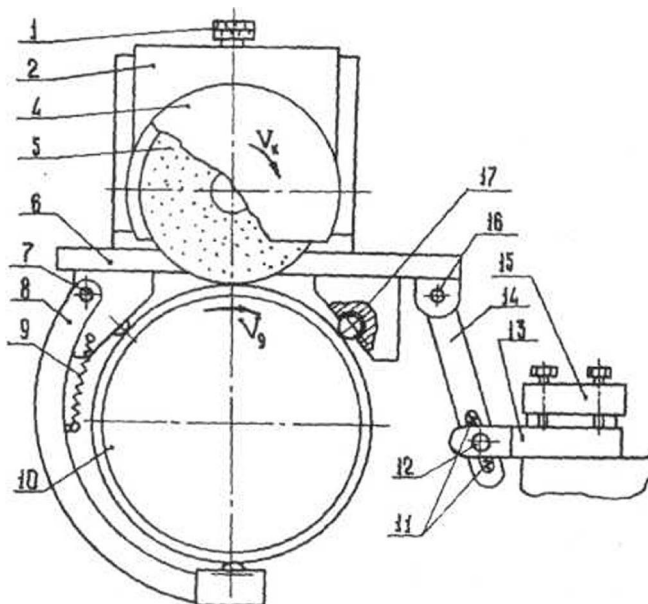

**Fig 1.** Machining device for grinding of hydraulic cylinders parts of large size

In the device by means of a micro screw 1 of vertical feed, a bed carriage 2 with attached to the carriage an electric motor 3 with a protective cap 4 and with a grinding disk 5, it is possible to set the vertical disk movement towards a platform 6, which by means of a pin 7, a bracket 8 and a spring 9 is fixed on a work piece 10. The platform together with the grinding disk can be moved towards a machine part by means of springs 11, a trunnion block 12, a pull-rod 13 and a crank arm 14 by means of a cutter holder 15, fixed on a bed carriage of a turning (or grinding) machine.

Parts 11,12,13,14 provide flexible joint of the bed carriage and the cutter holder with the platform 6 and compensate their mutual movement towards to each other.

The platform 6 is install on the machine part on the four upper bearing parts 17 and is supported by two same bearing parts at the bottom.

The device operating principle is that the platform 6 with a grinding disk 5 and its electric drive are placed on the top of the machine part 10, and are held down by the bracket 8 and by means of the pull-rod 13 is connected with the cutter holder 15. The machine tool is turned on and the desired speed of part rotation is set up; then the grinding disk is driven to rotate, it is approached to the machine part by vertical feed and is plunged into the part to the desired cut depth. The longitudinal feed of a bed carriage of the machine tool is turned on and cylindrical grinding process of parts along its length is carried out.

For the device roll off from the treated part the special adapter is installed between the back center of the machine and the work piece. The diameter of the adapter corresponds to the diameter of the treated work piece, and its length is equal to the required length of overrun beyond the part edges.

The grinding disk is located behind the bearing parts 17, so it eliminates the possible violations of the treated surface by the trunnion ball 17.

Another progressive method of parts treatment of hydraulic cylinders is the introduction of rotational-abrasive grinding (circular plunge grinding) for cutting parts and grooving [8].

The scheme of such grinding method is shown in Fig. 2.

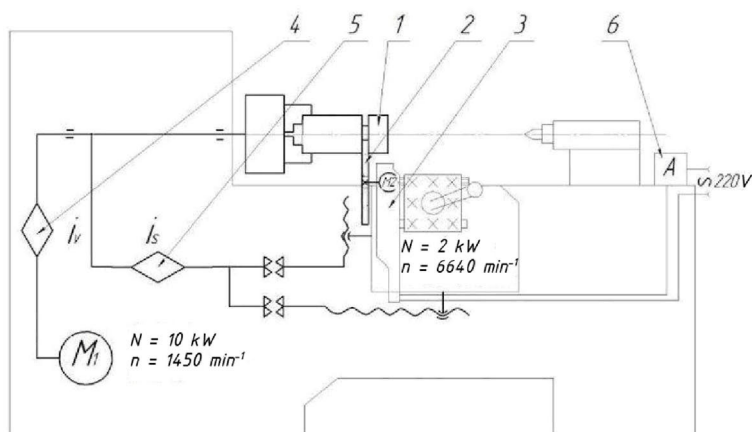

**Fig 2.** The scheme of rotational-abrasive grinding for cutting parts and grooving

To implement the method a turning machine is used, the model of which is chosen according to the size of work pieces.

The treated work piece 1 is fixed in the chuck of the machine tool and the treatment is done by a cutting grinding disk 2, which is installed on the main spindle of the angle grinder (AG) 3, which is fixed on the cutter holder of a machine tool. The part rotation frequency and the magnitude of cross-feed of a disk are regulated by the speed box 4 and

feed box 5 of a turning machine. The ammeter 6, built-in AG chain, serves for registration of grinding effective power.

Instrumental improving of the treatment efficiency of parts of hydraulic cylinders can be considered the way, associated with the design, manufacturing and application of new advanced constructions of grinding tools, consisting of grains of certain form, and oriented in the tool body in a given direction.

The fact is that the standard grinding tools are made from grains of optional form, randomly placed in the tool body [9, 10]. That is why, only a small portion of such grains of the tools randomly acquires favorable geometry for cutting and cut metal. Most of the grains are not taking part in the overall micro cutting process or participates in it in a minimum volume, deforming and heating the metal. The share of active grains, ensuring the removal of metal, according to the data of various researchers, is only 10-15% of their potential possibilities [11]. Thus, there is a substantial reserve of unused grains possibilities, determined by their relatively low physical and mechanical properties, and also by their unfavorable and uncollected geometry of cutting parts.

The geometry of the grains is determined by two factors – their form and location on the working surface of a grinding tool. Grains form, due to the specificity of their manufacturing technologies [12, 13] by abrasive ingot crush and subsequent sizing of obtained abrasive mass into fractions with different particle size, varies within a wide range from isometric to plastic types. More accurate quantitative classification of grains form can be given by so-called form coefficient ( $C_f$ ) equal to the ratio of diameters of inscribed and described spheres (in volume) or circulars (on the plane) into grains configuration. Developed the software that allows in automatic mode to determine the numerical values of the coefficients of the grains forms of various fractions according to the analysis of single grains in amount of at least 50-100 pieces.

To separate the original abrasive mass on the number of fractions with the grains of the same form the construction of the special vibratory separator was developed, which was patented and has a certificate for the invention of the Russian Federation (Patent 2248851 Russian Federation). To give a particular orientation to grains in a grinding disk, there was a method proposed, based on the usage of electric static effect, which is also patented (Patent 2369474 Russian Federation).

Thanks to the proposed methods to separate grains according to form and to give them a specific position in the tool body, it was possible to develop a technology to create new designs of grinding tools with controlled grains form and orientation. During the implementation of this technology the mixing machine was also developed to prepare the abrasive molding compounds. The remaining stages of the new technology don't fundamentally differ from the standard one and are completed by forming and heat treatment operations of grinding disks.

### **3 Results and Discussions**

The device was developed in the way that allows grinding of a part of the hydraulic cylinder with high-quality and productively, while the cylinder is being manufactured or repaired and reconstructed. The device exploitation at the factory confirmed its effective functioning and the ability to perform the given tasks.

The principle included in the design of this device (the combination of parts and tools bases), allows under hard radial run-outs of samples to polish not only the plungers of hydraulic cylinders, but other similar parts. For example, axle trees and large diameter pipes, cylinder containers and others.

Rotational abrasive cutting and grooving has a number of advantages in comparison with conventional forms of treatment [14]. Among them there are:

- reduction of grinding temperature and, as a consequence, the elimination of burns on the parts due to their rotation and continuous displacement of the contact area and the part (each local area of the part manages to cool until the next contact with the tool);
- the tool is less intensively heated and worn;
- there are no flash and sharpened edges on the part after such treatment.

Besides axisymmetric cylindrical parts the work pieces of other sections (square, rectangular, elliptical, etc.) may be subjected to this kind of treatment.

New constructions of grinding tools with controlled form and orientation of the grains with enhanced effectiveness were developed. Comparative tests of this tools with standard ones demonstrated their advantages in a number of operational parameters [15, 16]. The utilization of these tools for grinding of parts of hydraulic cylinders increases the productivity and quality of their production.

Discussion of the results described above is reflected in the previous section. The results of the developments according to paragraph 2 suggest that a differentiated and well-reasoned approach to the choice of the form and orientation of grains in grinding disks gives a significant increase in their performance. In particular, in the schemes of Fig. 3 – Fig. 4 it is shown that the cutting capacity ( $Q_m$ ) and surface roughness ( $R_a$ ) is directly dependent on the form of the grains in a disk ( $C_f$ ).

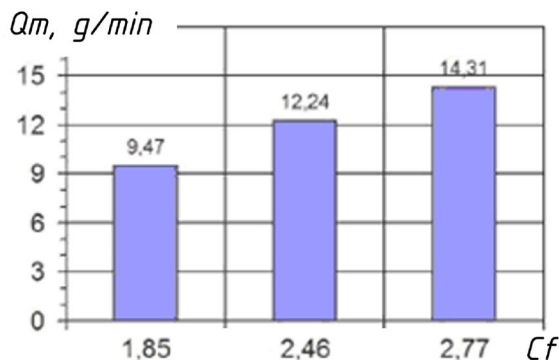

**Fig 3.** Cutting capability of disks with controlled form of grains

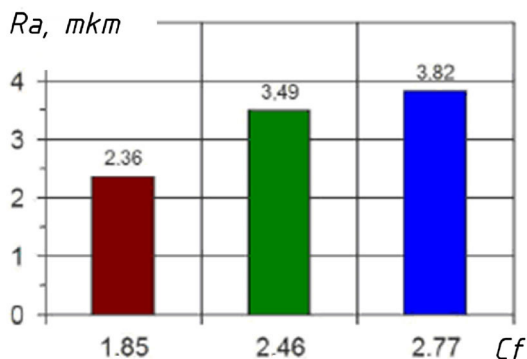

**Fig 4.** The roughness of the surface, treated by disks with controlled grains form

Specifically:

- with transition from isometric grains to grains of needed-plastic form the cutting capability of grinding disks, in dependence on the trade mark of abrasive and grinding scheme and condition increases in 1.51 times (Fig. 3);

- reduction ratio of grains form (transition to the isometric forms) can reduce the surface roughness in 1.6 times (Fig. 4);
- cutting capability of disks with grains oriented in the radial direction in 1.25-1.27 times higher than of conventional tools;
- application grains form with a tangential orientation in disks makes it possible to reduce the roughness of treated surfaces in 1.28-1.97 times.

## 4 Conclusion

The researches have confirmed the initial idea that parts of hydraulic cylinders used in mining engineering can be manufactured, repaired and reconstructed productively and efficiently by application of the proposed technological and instrumental approaches.

## References

1. V. Korotkov, S. Petrushin, *Applied Mechanics and Materials*, **682** (2014)
2. A. Hirsch, *Werkzeugmaschinen. Grundlagen, Viewegs Fachbuecher der Technik* (2000)
3. *Taschenbuch Maschinenbau* (Verlag Technik Berlin, 1978)
4. *DIN 69 651 Werkzeugmaschinen fuer die Metallbearbeitung*, (Verlag Berlin, 1982)
5. *Werkzeuge. Fachkatalog* (Verlag Berlin, 1992)
6. A. Korotkov, D. Shatko, *Applied Mechanics and Materials*, **788** (2015)
7. W. Koenig, *Fertigungsverfahren, Band 1 bis 5* (VDI-Verlag, Duesseldorf, 1990)
8. V. Korotkov, *IOP Conf. Series: Materials Science and Engineering*, **91**, 012041 (2015)
9. V. Lukshin, *Applied Mechanics and Materials*, **682** (2014)
10. G. Lal, M. Shaw, *Works of American union of engineers*, **97** (1975).
11. V. Lukshin, A. Barsuk, R. Fazleev, *IOP Conf. Series: Materials Science and Engineering* **91**, 012047 (2015)
12. A. Korotkov, A. Hirsch, *IDR*, **2** (2002)
13. W. Degner, H. Lutze, E. Smejkal, *Spanende Formung: Theorie, Berechnung, Richtwerte* (Carl Hanser Verlag Muenchen Wien, 1993)
14. *Verein Deutscher Werkzeugmaschinenfabriken e. V. (Hrsg.): Werkzeugmaschinen Bezugsquellenverzeichnis*, (Ausgabe, Frankfurt am Main, 1997)
15. *Development Methods and Application Experience of Parallel Kinematics* (Verlag Wissenschaftliche Scripten, 2002)
16. *Handbuch der Metallbearbeitung* (Verlag Europa-Lehrmittel, 2000)