

Increasing the Reliability of the Work of Artificial Filtering Arrays for the Purification of Quarry Waste Water

Maxim Tyulenev^{1,*}, Yury Lesin¹, Oleg Litvin¹, Elena Maliukhina², and Asmelash Abay³

¹ T.F. Gorbachev Kuzbass State Technical University, 28 Vesennyyaya st., Kemerovo, Russian Federation, 650000

² National Mineral Resources University (University of Mines), Faculty of Mining, Department of Surveying, 21 Line 2, St. Petersburg, Russian Federation, 199106

³ Department of Earth Science, College of Natural and Computational Sciences, P.O.Box.3066, Mekelle University, Mekelle, Ethiopia

Abstract. Features of geological structure of the Kuznetsk coal basin stipulate the application of a low-cost open technique of coal mining, which is more advantageous both from the economic standpoint, and by safety criteria of mining. However, open mining affects significantly the water resources of region. Intensive pollution of reservoirs and water courses, exhaustion of the underground water-bearing layers, violation of a hydrographic network, etc. be-long to the main disadvantages of an open technique of coal mining. Besides, the volume of the water coming into the mining producers exceeds significantly the needed quantity. According to the data of annual reports of ecology and natural resources department, 348.277 million m³ of water were taken away during production of soft coal, brown coal and lignum fossil from waters of Kemerovo region in 2013 (mostly from underground water objects (96,5%) when draining of mine openings). At the same time, only 87.018 million m³ of water (25%) has been used within a year.

1 Introduction

Industrial complexes concentrated in the most developed part of the biggest Russian coal basin – Kuzbass (Kemerovo Region, Western Siberia) – have the decisive influence on the ecological condition of environmental objects [1-2]. The decrease of production from the mid-1990s in the coal-mining areas of Kemerovo region has not led to the improvement of its environment. The negative effect made by coal-mining enterprises on the natural environment has complex origination. We observe an intensive pollution as a result of the influence of coal deposits open-pit mining on the atmosphere, water resources and landscape complexes. Complex processes of environmental anthropogenic changes caused by open pits' operations have brought to light the problem of surface water pollution near large mining segments. Currently, the volume of coal production in Kemerovo region amount to

* Corresponding author: tma.geolog@kuzstu.ru

more than 210 million tons per year. According to the report of supervisory environmental authorities in 2015, coal-mining enterprises of Kemerovo region disposed 1.239 billion m³ of wastewater, including inadequately treated – 228.8 million m³.

The main source of pollutants' transportation into the surface waters near the territories of open-pit mines is quarry water, resulting from massive extraction of groundwater of developed coal seams for draining purpose.

The issue of wastewater treatment in open pit mining of mineral deposits causes great ecological problems [3-5]. Due to the constant tightening of the requirements to the quality of discharged wastewater their treatment in settling basins and purifying ponds does not provide the parameters of maximum permissible concentration (MPC). Moreover these treatment facilities occupy large areas of land. Also it should be noted that usually there are several distanced weir wastes, which location is changed during development of mining. For example, JSC "KuzbassRazrezUgol" (Kuzbass, Western Siberia, Russia) has 32 places of water use, taking into consideration that the structure of this coal company consists of 7 large open pits.

2 Materials and methods

As an alternative coal enterprises may use expensive wastewater purifying equipment, which include different devices like hydroclassifiers, electrocoagulators, modules of water clarifying and sludge thickening, modules of sludge dewatering, finalizers, aerators and so on. Complex of such equipment for purifying highly voluminous quarry wastewater may totally cost up to several million dollars. So because of these large expenses at present time even prosperous Kuzbass coal open pits conduct wastewater treatment in artificial filter arrays made of waste coal. But the quality of purifying this way is quite low and does not match MPC.

Taking into account the upward trend in open pit mining of coal in Kuzbass, and as a consequence inevitable growth of the volume of discharged water by the coal enterprises, further study of improvement the environmental safety of mining operations is needed.

3 Results and Discussion

The technical solution to the problem of wastewater treatment from suspended solids in the filters of coarse rocks can be searched in two ways. The first of them is to use the discrete rocks arrays existing at enterprises as filters, after a preliminary examination. Such arrays include overburden rock arrays, refuse heaps and various technological dumps.

The second way is the purification of water in specially constructed filtering arrays of rocks and semi-rocks, which are, as a rule, the mining waste.

The filters' design depends on the terrain and the properties of the upper layers of the ground of the underlying surface, and the parameters are determined by the volume of water supply, its pollution density and filtration characteristics of the filtering material.

The main filter elements are the unit for supplying polluted water, filtering array, filter body, a device for collecting and draining the purified water. If there are any natural or artificial hollows (ravines, logs, river beds of dried-up rivers, trenches, ditches, abandoned mines and others) near the water disposal and low permeable rocks that lie at their sides and bottom, the latter can be the body of the filter, fig. 1. In this case, water may be supplied to the filter array by gravity on a surface or pipe and by pumping. The filter array is piled from rocks that meet the relevant requirements using trucks and bulldozers.

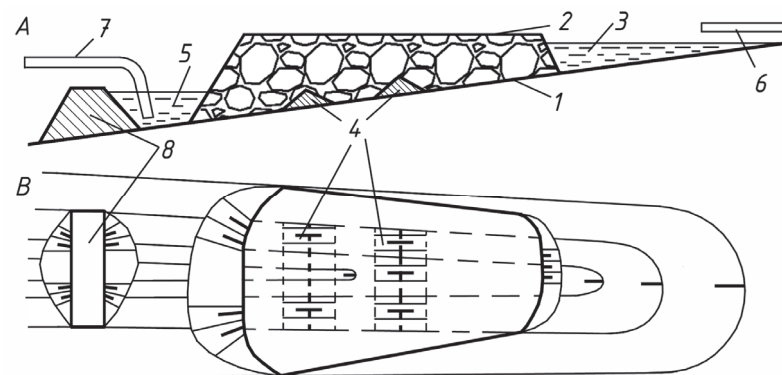

Fig. 1. Construction of the filtering array with waterproof stopping: A – longitudinal section; B – plan view; 1 – the bottom of the filter; 2 – filtering array; 3 – receiver for contaminated water; 4 – waterproof stopping; 5 – lodgment of purified water; 6 – conduit for feeding for contaminated water; 7 – conduit for purified water removing; 8 – water retention levee.

A pond appeared as the result of water infiltration becomes a device for supplying and routing water in the filter. The retaining dam for collection and turning out the purified water must be constructed of the rocks with low hydraulic permeability lower filter array. The disposal of pure water from water reservoir is produced by gravity in chutes or pipes in order to prevent the erosion of soil and new water pollution. When water discharge by gravity is impossible or there is a necessity of its subsequent use for enterprise needs pumping station should be installed.

If rocks of the sides and bottom of the hollows are characterized by high hydraulic permeability, to prevent infiltration of water into the ground and possible pollution of aquifers bottom filter forming is necessary. The bottom is arranged by dumping the low permeable rocks, followed by their layout and thickening by bulldozers. To prevent losses the water for cleaning must be supplied by chutes or pipeline.

Another method of supplying contaminated water to the filtering array is also proposed in this paper. In this case, water is supplied to the additional receiver for contaminated water 9 that created directly in the filtering array 2.

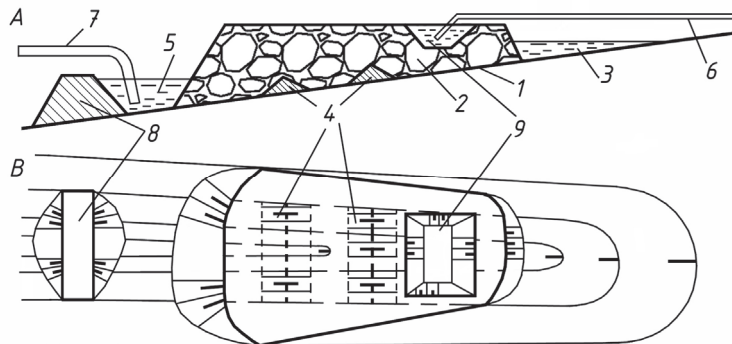

Fig. 2. Construction of the filtering array with waterproof stopping and additional receiver: A – longitudinal section; B – plan view; 1 – the bottom of the filter; 2 – filtering array; 3 – auxiliary receiver for contaminated water; 4 – waterproof stopping; 5 – lodgment of purified water; 6 – conduit for feeding for contaminated water; 7 – conduit for purified water removing; 8 – water retention levee, 9 – additional receiver for contaminated water.

The technology of such massive construction at the initial stage is no different from the previous method, but after the work is completed and the filter body is sealed, the backhoe with a small bucket capacity (and minimum mass, respectively) creates a recess at a safe distance from the top edge of the filter.

The depth and width of this additional receiver are determined in each case individually. This method has the following advantages:

- 1) the water entering the treatment is filtered through the upper small-lump layer of the massif, which increases the degree of its purification;
- 2) the water supplied to the purification is distributed more evenly through the array, which reduces the probability of its untimely siltation.

However, this method has limited application due to the fact that it is not always possible, firstly, to place equipment on the upper platform, and secondly, because of the peculiarities of the terrain that make it difficult to manage and maintain the pipeline of contaminated water.

As an example, Fig. 3 depicts a real array with a potential receiver shown on it.

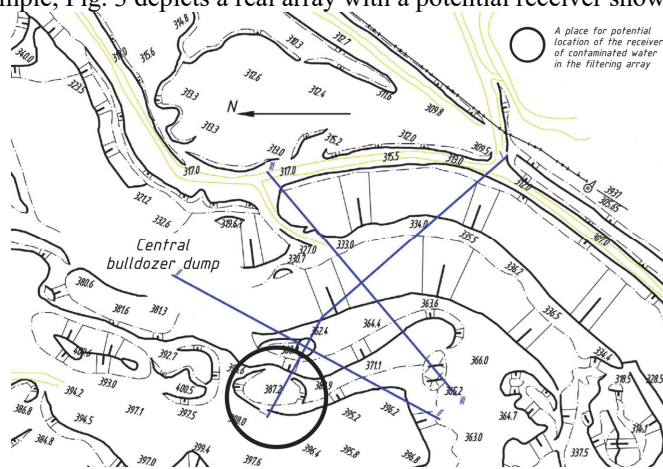

Fig. 3. Scheme of real filtering array with potential place for additional receiver.

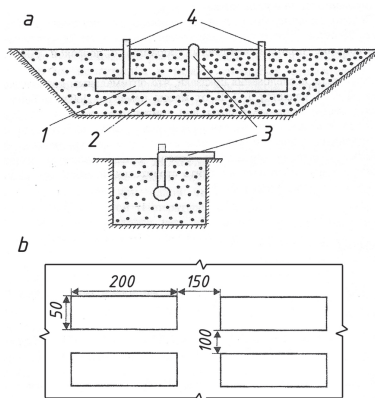

Fig. 4. Constructive scheme of filtering array.

There is also a method of supplying water to an array similar to the previous one, but without the construction of an additional receiver. In this case, water is supplied through pipes reinforced directly in the body of the massif (Fig. 4). Pipes are equipped with perforation for an even distribution of water, the depth of their laying is usually up to 5 meters.

Such a method guarantees continuous operation of the filter throughout the year and excludes the possibility of freezing the water intake point.

4 Conclusions

Development of effective quarry water purifying technology requires cooperation of technical universities, research organizations and mining enterprises for saving the environment in coal basins. Technology of forming and using filter arrays allows substituting expensive water treatment equipment what was proved by conducted research. In general high perspectives of the new technologies of quarry water treatment implementation at surface mining are expected to expand the limits of using mining machines.

References

1. T.V. Kiseleva, V.G. Mikhailov, V.A. Karasev, IOP Conf. Ser.: Earth Environ. Sci., **45:1**, 012013 (2016)
2. T.V. Galanina, M.I. Baumgarten, V.G. Mikhailov, T.G. Koroleva, G.S. Mikhailov, IOP Conf. Ser.: Earth Environ. Sci., **50:1**, 012030 (2017)
3. M. Tyulenev, Y. Lesin, E.Tyuleneva, E. Murko, E3S Web of Conf., **15**, 02003 (2017)
4. M. Cehlár, P. Varga, Z. Jurkasová, M. Pašková, Acta Montanistica Slovaca, **15:2**, 132-138 (2011)
5. M. Tyulenev, E. Garina, A. Khoreshok, O. Litvin, Y. Litvin, E. Maliukhina, IOP Conf. Ser.: Earth Environ. Sci., **50:1**, 012035 (2017)

