

Disk Rock Cutting Tool for the Implementation of Resource-Saving Technologies of Mining of Solid Minerals

*Leonid Mametyev*¹, *Aleksey Khoreshok*¹, *Alexander Tsekhin*¹, and *Andrey Borisov*^{1*}

¹ T.F. Gorbachev Kuzbass State Technical University, 650000, 28 Vesennaya St., Kemerovo, Russia

Abstract. The directions of a resource and energy saving when creating a boom-type effectors of roadheaders of selective action with disc rock cutting tools on a multi-faceted prisms for the destruction of formation of minerals and rocks pricemax are presented. Justified reversing the modes of the crowns and booms to improve the efficiency of mining works. Parameters of destruction of coal and rock faces by the disk tool of a biconical design with the unified fastening knots to many-sided prisms on effectors of extraction mining machines are determined. Parameters of tension of the interfaced elements of knots of fastening of the disk tool at static interaction with the destroyed face of rocks are set. The technical solutions containing the constructive and kinematic communications realizing counter and reverse mode of rotation of two radial crowns with the disk tool on trihedral prisms and cases of booms with the disk tool on tetrahedral prisms in internal space between two axial crowns with the cutter are proposed. Reserves of expansion of the front of loading outside a table of a feeder of the roadheader of selective action, including side zones in which loading corridors by blades of trihedral prisms in internal space between two radial crowns are created are revealed.

1 Introduction

In leading mining countries, the main means of mechanization of mining operations are roadheaders, shearers, plough system and drilling machines. Improvement of the effectors of roadheaders boom type by rational combination and the allocation of cutter and disk tool for the implementation of the principle of the destruction of coal and strong rocks major cleavage to resource and energy conservation is a topical scientific and technical problem.

2 Materials and methods

Modern mining machines is implemented by mechanical destruction method of coal and rock faces using the broad structural spectrum of mining tools. It is known that the destruction of rocks by cutting is an energetically favorable process [1]. However, in the abrasive rocks of medium and above medium strength, this method is not practically acceptable, in connection

* Corresponding author: borisovau@kuzstu.ru

with the intensive wear of the working tool, due to the inability to transfer a large power unit is required for destruction of the face. Therefore, the area of effective application of the destruction of rocks by cutting is limited to breed with a little abrasiveness (less than 15 mg) with a limit of compressive strength up to 60 MPa.

Studies in KuzSTU justified by the prospects of using the disk tools on the effectors of mining machines.

Working conditions mining tool for boom-type roadheaders necessitates the identification of functional possibilities of using the disk tools on the crown effectors.

The complex of requirements to the construction of the crowns boom-type roadheaders selective action is based on the interdependence of kinematic, power and design parameters of the attachment disc tool with the physico-mechanical properties and fracture parameters of faces and the provision of installation and dismantling operations.

To enhance the functionality of the effectors of roadheaders selective action via combining the processes of destruction, loading and crushing of rock mass proposed disk tools with the attachment to the triangular prisms in the construction of two reversible radial longitudinal axis of the crowns (fig. 1) [2].

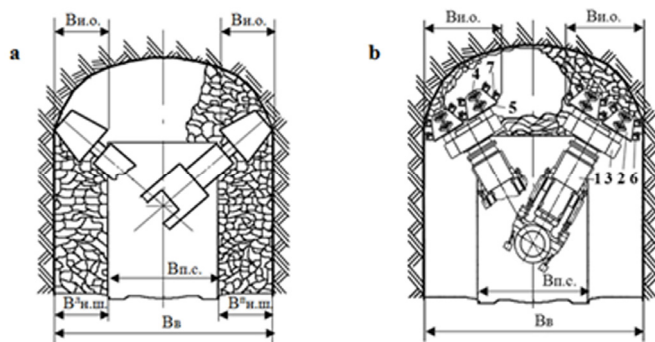

Fig. 1. Work boom-type effector with the radial crowns: a – prior to modernization; b – after modernization.

The effector of roadheader (fig. 1, b) contains an boom 1, which has two destructive loading of the crowns 2, kinematically connected through the transfer case gear 3. Each crown 2 consists of truncated cones or prisms with a small base 4 and a big base 5, a hub which is attached to the output shaft of the gearbox 3. To the outer surfaces of crowns attached triangular prism 6 with disc tools 7. Gear kinematic connection allows the triangular prisms 6 crowns 2 during rotation to create a spatial mazes and corridors, providing combination of the processes of destruction, crushing and loading within the project of the width B_B of the driven working. The process of loading zones in the cut off parts of tunnel production is characterized by the following parameters: $B_{н.о.}$ – working width of the effector along the sides; $B_{н.ш.}$ и $B_{н.ш.}^n$ – width is not shipped stacks of destruction products from the left and right sides; B_B – width of project development; $B_{п.с.}$ – the width of the delivery table of the feeder of the loading device, characterizing the width of the zone of the front loading.

The department of mining machines and complexes KuzSTU in cooperation with the department of mining equipment of YUTI (branch) of Tomsk Polytechnic University conducted studies of the stress-strain state of various designs of the cantilever attachment disk tool by the finite element method. One of the results of the study of the stress state of the mounting disk tool to a triangular prism with the nut shown in fig. 2 [2].

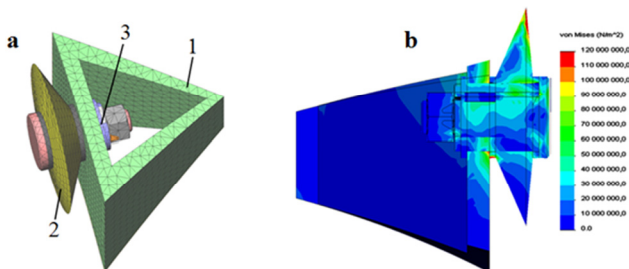

Fig. 2. Finite element model (a) and stress state (b) option of the mount of the disk tool are: 1 – triangular prism; 2 – disc; 3 – nut.

In three constructive variants of the attachment (strap, screw and nut) used biconical and conical disk tools. As an example, in fig. 2, b shows the distributions of the equivalent stress according to Mises for disk tool diameter $D = 0,16$ m.

The console variants of the attachment of the disk tool on the triangular prisms taking into account the results of modeling the stress-strain state in the destruction of coal and rock faces are recommended to equip their working bodies roadheaders, shearers and drilling machines.

The main disadvantage of many of the effectors of roadheaders cross-axial design is the low productivity of the process of the cutting to the presence of an indestructible block coal and rock faces in the space between the crowns (fig. 3) [3].

The department of mining machines and complexes KuzSTU to improve the efficiency of the process of the cutting of the effector roadheader of selective action with cross-axial crowns separated from each other by the casing of the distributing reducer proposed in the space between the crowns to place the disk tools on tetrahedral prisms.

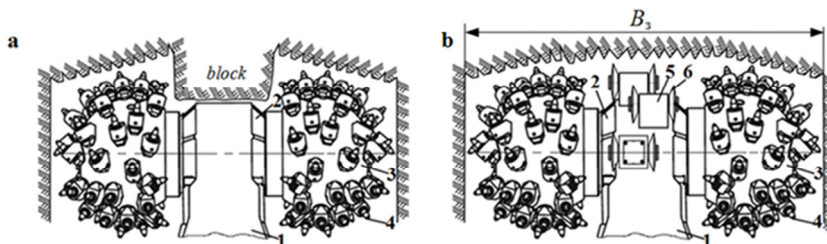

Fig. 3. Cutting effectors: a – analog; b – upgraded

In the process of the cutting (fig. 3) boom 1 the effector with the distributing gearbox 2, axial crowns 3, cutters 4, tetrahedral prisms 5 with disc tools 6 make a vertically rotatable planing motion with simultaneous telescopic effect on the face. In this block (fig. 3, a), which is formed by the standard of the effectors-analogues is destroyed in the space between the crowns of disk tools 6 on the tetrahedral prism 5 (fig. 3, b). Part of the body of the distributing gearbox 2 boom 1 turned to face and made in the form of a cylindrical sector, on the outer surface of which are mounted in a staggered tetrahedral prism 5 with the disk tools 6, fitting into the space gap between lines of cut formed by the outermost cutters 4 of side large grounds axial crowns 3. Thus the radial departure of V-cutting edges of the tool disk 6 does not exceed the radial departure of the extreme cutters 4 on large grounds axial crowns 3. It allows to be effectively cut to the width B_3 (fig. 3, b) due to movement of the boom 1 during the cutting in the vertical plane with a telescopic effect. In the case of step processing slaughtering axial crowns 3 is carried out the turning movement of the boom 1 in a horizontal plane to the right or left sides of the excavation.

Similarly, a procedure for the construction of finite element models and calculation efforts loadings P_z, P_y, P_x , disc tool with the attachment on tetrahedral prisms. In fig. 4, a finite element model of a tetrahedral prism with disc tools creating an additional fracture zone in the space

between the crowns effector of roadheader. For the initial conditions to calculate the parameters of the stress state was chosen ranges of the characteristics of the destructible faces: coal ($\sigma_{\text{сжк}} = 12,4; 13,5; 14,8$ MPa) and the rock ($\sigma_{\text{сжк}} = 51; 60,6; 78,9$ MPa). In the simulation used four possible designs of disk tool diameter $D = 0,16$ m (three biconical with pointed angles: $\varphi = \varphi_1 + \varphi_2 = 25^\circ + 5^\circ = 30^\circ; 20^\circ + 10^\circ = 30^\circ; 15^\circ + 15^\circ = 30^\circ$ and one conic $\varphi = 30^\circ$) [3].

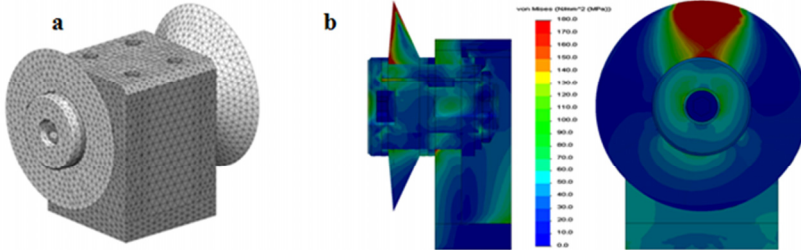

Fig. 4. Finite element model (a) and stress state (b) option of the mount separate disks ($\varphi = 25^\circ + 5^\circ = 30^\circ$) to the tetrahedral prism in the destruction of the rock mass $\sigma_{\text{сжк}} = 78,9$ MPa.

The calculation was performed in SolidWorks Simulation. Meshing was used parabolic finite elements in the form of tetrahedra. The size of the finite elements was chosen so that further increase in mesh density had no significant effect on the results of the calculations. Material details 35HGSA, steel 45. The cutting force P_z , penetration P_y and lateral force P_x on the disc tools are subject to design, operating parameters and characteristics of the destroyed face $\sigma_{\text{сжк}}$. Computational effort of loading P_z, P_y, P_x was applied to finite element models (fig. 4, a) disk tools the attachment in tetrahedral prisms to produce pictures of the stress-strain state for biconical and conical disc tools (fig. 4, b).

On the basis of the analysis of the basic constructive solutions [4-13] proposed the original technical solution, which includes tetrahedral prisms with dual disk tools (fig. 5), made as a single prefabricated structural unit with the joint possibility of free rotation relative to the fixed axle-bushings. Its implementation provides for joint rotation of the two disc tools on each tetrahedral prism with a decrease in the process of jamming and wear in the cut of the boom-type effector of roadheader in the massif [4].

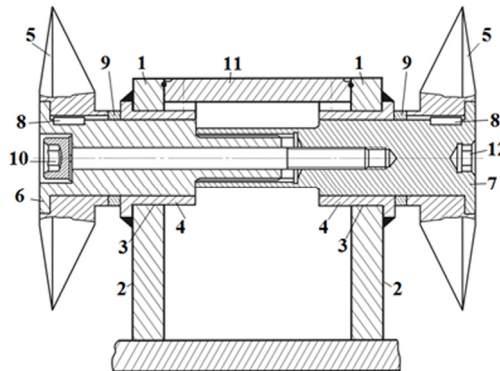

Fig. 5. Design tetrahedral prism with dual disk tools.

Tetrahedral prism 1 (fig. 5) consists of two working faces 2 with a through cylindrical holes 3 and two side faces. Inside each of the through cylindrical holes 3 is placed the axle-bushing 4. While paired disk tools 5 made as a single dismounted and mounted structural unit with the possibility of a joint free rotation about fixed axle-bushing 4. Each axle-bushing 4 consists of an end thrust collar rigidly attached to the outer surface of the working faces 2 tetrahedral prism 1 and the cylindrical surface of the console placed in a through cylindrical hole 3 of the working

face 2 in the internal space of the tetrahedral prism 1.

A single dismounted and mounted constructional unit made in the form rigidly attached to each other two axes 6, 7 from the with thrust ribs, one of which contains a slotted shank, and the other contains the spline hub. Axis 6, 7 have the zones providing connection of the disk tool 5 by means of dowel-pawl 8. Remote face of the washer 9 is placed between the end faces of each of the two disc tools 6 and the end faces of the thrust ribs of each of the two axle-bushings 4. The axle 6 is formed with a stepped through hole, inside which is placed remote the screw 10 for fastening a single dismounted and mounted structural unit. For protection of internal space of a tetrahedral prism 1 use a tetrahedral cover 11. From the free end of the axle 7 is made hexagonal recess 12 under the key for the implementation of installation and dismantling operations.

3 Results and discussion

Found that equivalent stress according to Mises all versions of the attachment disk tool radial crowns roadheaders is substantially below the yield strength for steel 35HGSA ($\sigma_T = 490$ MPa). With the transition from asymmetry to symmetry biconical disk tools can be traced to the reduction zone settings equivalent stresses in the attachment points with the general increase in maximum stress with the increase of rock strength in a wide range $\sigma_{\text{сжк}} = 50-120$ MPa.

It is revealed that, disk tools conical ($\varphi = 30^\circ$) and biconical performances ($\varphi = 25^\circ+5^\circ = 30^\circ$) implement the process of breaking larger areas of maximum equivalent stresses and displacements than alternatives biconical version ($\varphi = 20^\circ+10^\circ = 30^\circ$ and $\varphi = 15^\circ+15^\circ = 30^\circ$), and the minimum sizes of zones of equivalent stresses and displacements observed for the biconical design ($\varphi = 15^\circ+15^\circ = 30^\circ$).

Decrease in the sizes of zones of the maximum equivalent tension and movements on a bottomhole side of the trihedral prism turned to a face for option of knot of fastening of the disk tool by a nut, in comparison with fastening by the screw is noted that characterizes higher rigidity of fastening by a nut.

Technical solutions and test results were obtained within the base part of Ministry of Education and Science of Russia state order, project 632 "Investigation of technologies and techniques parameters for selecting and developing innovative designs to improve operating efficiency of multipurpose mining machines in Kuzbass".

4 Conclusion

1. One of the directions of energy saving in underground coal mining or mineral raw materials is to reduce the downtime of roadheaders and to increase the rate of penetration of preparatory workings by the extension of front loading before the cut off parts zones using the original boom-type effectors with two radial crowns and disk tool on the triangular prisms.

2. Proposed to reduce the energy intensity and time of cutting boom-type by the roadheaders of selective action using the disk tool in tetrahedral prisms in the inner space between the axial cutting units crowns.

3. Additional factors of resource-saving are to a significant increase in durability and service life of disc rock-destructive tools compared to cutters for reducing the cost of maintenance and repair in the face space.

References

1. A.A. Khoreshok, L.E. Mametev, A.Yu. Borisov, A.V. Vorobev, *Appl. Mech. Mater.* **770**, 429 (2015)

2. A.A. Khoreshok, L.E. Mametev, A.Yu. Borisov, A.V. Vorobev, *Applied Mechanics and Materials*, **770**, 434 (2015)
3. A.A. Khoreshok, L.E. Mametyev, A.Yu Borisov 2015 I Miner's Week – Reports Of The Xxiii International Scientific Symposium, 482 (2015)
4. B.L. Gerike, P.B. Gerike, V.I. Klishin, A.P. Filatov, *J. Min. Sci.* **44:5**, 497 (2008)
5. B.L. Gerike, P.B. Gerike, A.P. Filatov, V.I. Klishin, *J. Min. Sci.* **42:6**, 610 (2006)
6. P.B. Gerike, M.A. Belikov, *J. Min. Sci.* **39:2**, 162 (2003)
7. P.D. Krestovozdvizhensky, V.I. Klishin, S.M. Nikitenko, P.B. Gerike, *J. Min. Sci.* **51:2**, 323 (2015)
8. Y Zhang, X W Wang, H F Liu, *Appl. Mech. Mater.* **487**, 513 (2014)
9. K. Yang, Y. M. Xia, Y. S. Wu, *Appl. Mech. Mater.* **508**, 159 (2014)
10. A. N. Zhang, Z. F. Zhu, F. Zhu, *Adv. Mater. Res.* **791:793**, 742 (2013)
11. X H Li, W Du, Z L Huang, W L. Fu, *Appl. Mech. Mater.* **127**, 385 (2011)
12. G. Wittenberger, M. Cehlár, Z. Jurkasová, *Acta Montanistica Slovaca*, **17:4**, 241-246 (2012)