

# Transfer reservoir as a new solution for transfer of stormwater to water receivers

Robert Malmur<sup>1,\*</sup>

<sup>1</sup>Institute of Environmental Engineering, ul. Brzeźnicka 60a, 42-200 Częstochowa, Poland

**Abstract.** With frequent heavy rainfalls in summer in Poland and fast-melting snow in spring leading to flooding of sewage systems (due to excessive filling levels in water receivers or difficulties with temporary retention of the excess stormwater), a variety of systems are being developed to facilitate transfer of the stormwater to water receivers. Outflow of the excess stormwater is usually ensured by the use of gravitational outflow collectors that connect stormwater drains with waterways. The transfer occurs during intensive precipitation, when the excess wastewater overflows through stormwater drains and is transferred directly to water receivers in order to relieve wastewater treatment plants or to minimize diameters of sewers. These systems are useful wherever the filling levels in waterways are not very high or the sewerage system is located relatively high with respect to the water receiver i.e. outflow collector is located on a steep slope. In such cases, the stormwater that flows through a waterway cannot be returned to the outflow collector. If the gravitational flow is impossible e.g. due to the excessive filling level of water receiver, stormwater can be transferred by means of a variety of modern solutions, such as retention and transfer reservoirs. These reservoirs are supposed to ensure partial retention of the excess stormwater and transfer of this water to water receivers, either gravitationally or forced mechanically, depending on the filling level in the waterway. Furthermore, these reservoirs prevent wastewater from being returned to the system during suddenly rising levels. One of the solutions is offered by the reservoir presented in this paper. The transfer reservoir for the stormwater presented in this paper might be successfully used in modernization of current sewage systems, ensuring the reliability of operation and a more effective wastewater transfer than the systems used to date. All the reservoirs of this type are characterized by similar design and function and guarantee that the wastewater might be transferred regardless of the conditions in the water receiver. An essential feature of these reservoirs is the use of the effective method to control suction and pumping units.

---

\* Corresponding author: [rmalmur@is.pcz.czest.pl](mailto:rmalmur@is.pcz.czest.pl)

## 1 Introduction

Various countries all over the world use different solutions to the problem of wastewater transfer. There are plethora of solutions in the form of stationary pumping stations and portable pumping stations (e.g. in China). However, the outflow of excess wastewater from precipitation occurs gravitationally through outflow collectors that connect stormwater with waterways. Transfer of the wastewater directly to the water receiver during intensive precipitation occurs through stormwater drains. The aim of the use of stormwater drains is to relieve wastewater treatment plant and to avoid the necessity of the use of high diameters of sewers [1, 2]. These systems are useful wherever the filling levels in waterways are not very high or the sewerage system is located relatively high with respect to the water receiver. In such cases, the stormwater that flows through a waterway cannot be returned to the outflow collector.

A flap return valve is often installed at the outlet from the outflow collectors to prevent from flooding of the protected areas. Flap valves prevent from the backflow in the stormwater system caused by high levels of water in rivers [3]. However, in practice, these valves are not always used or are left without adequate supervision and maintenance. Consequently, poor state of repair usually limits efficient operation of these valves [4].

Unsecured outlets of outflow collectors or inefficiently operated flap valves have led in recent years to numerous instances of flooding in residential areas of many cities in Poland.

Another problem is observed in areas directly adjacent to rivers or artificial dams where raised water levels are much higher than land elevation. Such depressed areas with respect to constant filling on the other side of the embankment are deprived of natural conditions for water outflow from their drainage basin.

In such cases, building adequate stations for transfer of water from water receiver is critical. In practice, the pumping stations are located at the points of wastewater discharge.

In any case, if the surface water (also including stormwater from precipitation) is released directly to the water receiver (river), the protection in the form of flap valves installed on the river side of the embankment should be monitored and maintained at regular intervals. However, they become inaccessible in case of raised river levels [2].

The filling levels that make gravitational outflow impossible lead to the need for building a system of transfer of wastewater from the protected area to the water receiver.

The inefficient and often unreliable solutions of wastewater transfer have become the reason for starting the research on new and more efficient solutions to this problem.

Retention and transfer reservoirs for stormwater took over the function of the effective transfer of wastewater from precipitation to the water receiver. Wastewater transfer occurs if gravitational outflow is inhibited periodically or permanently.

Periodical inhibition of the transfer of wastewater from precipitation can be caused by high filling levels in the river, which are also observed in the period of intensive precipitation. Furthermore, permanent inhibition is observed if the dewatered areas are located in the depression with respect to the filling levels in the receiver due to the accumulation of water [5, 6].

Therefore, retention and transfer reservoirs can be used in the following cases [3]:

- in separated sewerage system at the outlets of main collectors in the stormwater system (Fig. 1a);
- in the combined sewer system at the stormwater channel outlets (Fig. 1b);
- in the combined sewer system at the stormwater channel outlets with simultaneous pumping of sanitary wastewater to wastewater treatment plant (Fig. 1c);
- in the case of collectors used to transfer wastewater from the treatment plant (Fig. 1d).

One of the most recent solutions of stormwater transfer to receivers is the use of the reservoir presented in this paper.

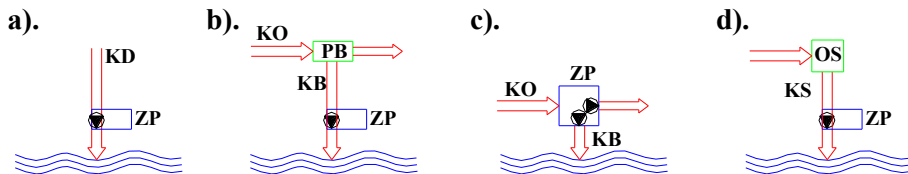

**Fig. 1.** Design of basic systems of reservoirs operated within different wastewater system arrangements. ZP – transfer reservoir; ZO – combined sewer channel; KB – stormwater channel; KD – stormwater collector; PB – stormwater drain; OS – wastewater treatment plant; KS – collector used to discharge wastewater after treatment.

## 2 Characteristics of the transfer reservoir

The transfer reservoir for stormwater discussed in this study can be built near channels of water receivers where the wastewater is supposed to be transferred to. The reservoir is supposed to be built near the flood embankment or embedded in the embankment [7, 8]. The reservoirs of this type can be used if the water receiver is located higher than the sewerage system and direct outflow of sewage to the receiver would be impossible.

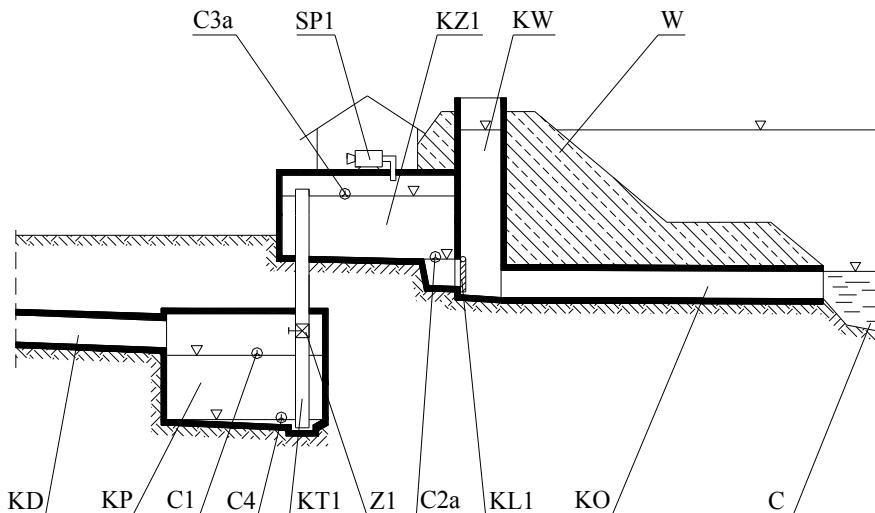

**Fig. 2.** Transfer reservoir of stormwater.

Principally, the reservoir is comprised of the following components: flow chamber, two pump chambers and tower chamber (Fig. 2 and 3). Wastewater to the reservoirs are transported to the flow chamber through outflow collector and discharged from the tower chamber to a water receiver through an outflow collector. The pump chambers are equipped in one-way flap valves, with the flow oriented towards the tower chamber. The flow chamber is connected with the pump chambers through pumping channels build in lower part of the flow chamber and in front part of pump chambers. Pump chambers contain cut-off valves that prevent from air access in particular cases. The reservoir is also equipped in electrical pump-compressor unit located over the pump chamber and controlled by means

of sewage level sensors build in the pump chambers and the flow chamber. The pumping units comprise of air-tight pump chamber and pump-compressor unit connected by means of suction and pumping channel through the roof to the pump chamber. The pump channels are connected to the hydraulic system between one-way flap valves build in the bottom zone with the flow oriented towards the tower chamber, whereas the pumping channels are connected with the flow chamber.

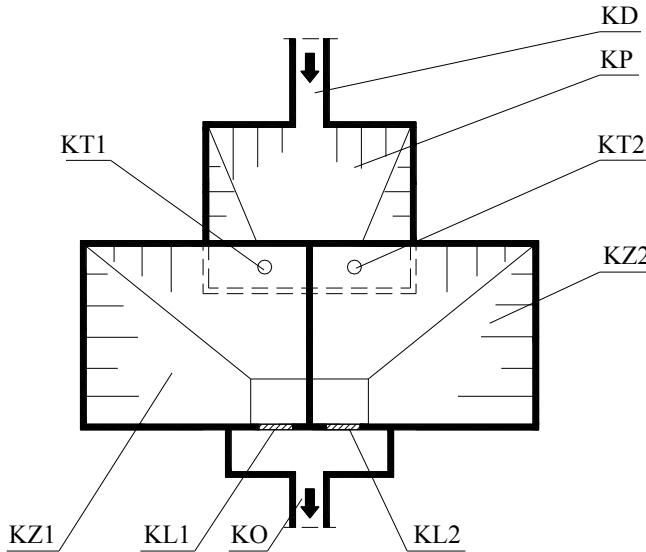

**Fig. 3.** Top view of the transfer reservoir.

An essential structural feature of the reservoir is that the flow chamber is built below the pump chambers. With this solution, sewage are transported to the flow chamber and then, through the pumping channels, to the pump chambers. Depending on the sewage level in the water receiver, sewage from pump chambers are transferred gravitationally or forced by pressure.

### 3 The design of transfer reservoir

Sewage flows to the reservoir through the inflow collector (KD) to the flow chamber (KP) (Fig. 2). There is a small cavity at the end of the flow chamber (KP), where pumping channels (KT1 and KT2) are connected. These channels are used to connect the flow chamber (KP) with pump chambers (KZ1, KZ2) (Fig. 3) through the wholes made in the front part of these chambers. The top of the pumping channels (KT1, KT2) reaches almost to the roof of the pump chambers (KZ1, KZ2). Pumping channels (KT1, KT2) have cut-off valves (Z1, Z2), build in the upper part of the flow chamber (KP). Pump chambers (KZ1, KZ2) are connected with the tower chamber (KW) through one-way flap valves (KL1, KL2) which operate automatically, oriented with the flow towards the tower chamber (KW).

The roof of the pump chamber (KZ1, KZ2) contains two pump-compressor units (SP1, SP2), connected through pipes with above-roof space of these chambers. The pump-compressor units (SP1, SP2) are of similar design and their flow rate equals at least the equivalent maximum inflow  $Q_{dopmax}$  present in a particular drainage basin. The pump chambers (KZ1, KZ2) are built as air-tight, they have similar volume and are designed next to each other.

The tower chamber (KW) is higher than the other chambers and reaches the height at least equal to the height of the crest of the flood embankment (W) of the waterway (C). Sewage from the tower chamber (KW) flows to the waterway (C) through an outflow collector (KO). The outflow collector (KO) runs along the bottom of the waterway (C) under the flood embankment (W), whereas the outlet of the collector is located under the water surface in the water receiver (C).

Sewage level sensors (C1, C2a, C2b, C3a, C3b, C4) that control operation of pump-compressor units (SP1, SP2) are built in pump chambers (KZ1, KZ2) and flow chamber (KP). The (C1) sensor is installed in the flow chamber (KP) at the height of several centimetres below the bottom of the inflow collector (KD), whereas the (C4) sensor is located at the bottom of the chamber, at the height of ca. 5 cm over the lower part of the pumping channels (KT1, KT2). Sensors (C2a, C2b, C3a and C3b) are built in the pumping chambers (KZ1, KZ2). Lower sensors (C2a, C2b) are located at the upper level of the flap chamber (KL1, KL2), whereas the upper sensors (C3a, C3b) are located at the height of ca. 5 cm below the upper part of the pumping channels (KT1, KT2).

## 4 The principle of operation of transfer reservoir

The sewage from sewage system flows through inflow collector (KD) to the flow chamber (KP), filling it up to the sensor level (C1) (Fig. 4). As soon as this level is reached, the pump-compressor unit (SP1) is actuated at the suction side. The pump-compressor unit (SP1) sucks the air out of the pump chamber (KZ1) and then, through a pumping channel (KT1), with the (Z1) cut-off valve open, starts sucking the sewage out of the flow chamber (KP). Flap valves (KL1, KL2) are closed as a result of the pressure from the water column in tower chamber (KW). The sewage pumped in the pumping channel (KT1) fills the pump chamber (KZ1) until the level of the (C3a) sensor (Fig. 5) is reached. With the signal from the C3a sensor, the pump-compressor unit (SP1) switches from suction into pumping and the cut-off valve (Z1) is closed in the pumping channel (KT1). The pressure in the below-roof space of the pump chamber (KZ1) rises, causing the flap valve (KL1) to open and sewage to be pumped to the tower chamber (KW). With low filling level in the waterway (C), the sewage opens the flap valve (KL1) with its own pressure force and flows through tower chamber (KW), outflow collector (KO) and finally gets into the water receiver (C). Furthermore, with elevated levels, pressure of the sewage is insufficient to open the flap valve (KL1). Therefore, the use of the pump-compressor unit (SP1) is needed (Fig. 6).

Capacity of the pump-compressor unit (SP1) was chosen so that emptying the pump chamber (KZ1) is possible with the outflow rate slightly higher than the measurable inflow. The pump-compressor unit (SP1) empties the pump chamber (KZ1) until the level of the C2a sensor is reached (Fig. 7).

Signal from the (C3a) sensor also causes the pump-compressor unit (SP2) to switch on at the suction side in the pump chamber (KZ2). When the pump chamber (KZ1) is being emptied, sludge from the flow chamber (KP) is sucked to the pump chamber (KZ2) through the pumping channel (KT2), with the cut-off valve open (Z2). Filling the pump chamber (KZ2) is continued until the time of reaching the level of the sensor (C3b), when the pump-compressor unit (SP2) switches into pumping. The cut-off valve (Z2) in the pumping channel (KT2) closes, preventing from unwanted air loss. At the same time, the pump chamber (KZ1) is emptied until the level reaches the sensor (C2a) and the sewage can be accepted again. The operation of the pump chambers (KZ1, KZ2) occurs alternately, which means that when one of them is filled, the other one is emptied. Pump-compressor units (SP1, SP2) operate until the sewage in the flow chamber (KP) reaches the level of the sensor (C4).



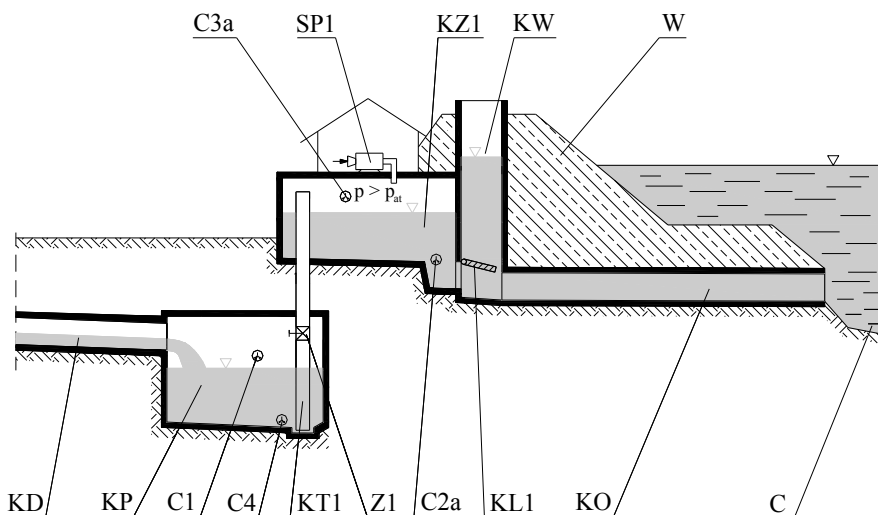

Fig. 6. Pneumatic flow of sewage in the transfer reservoir.

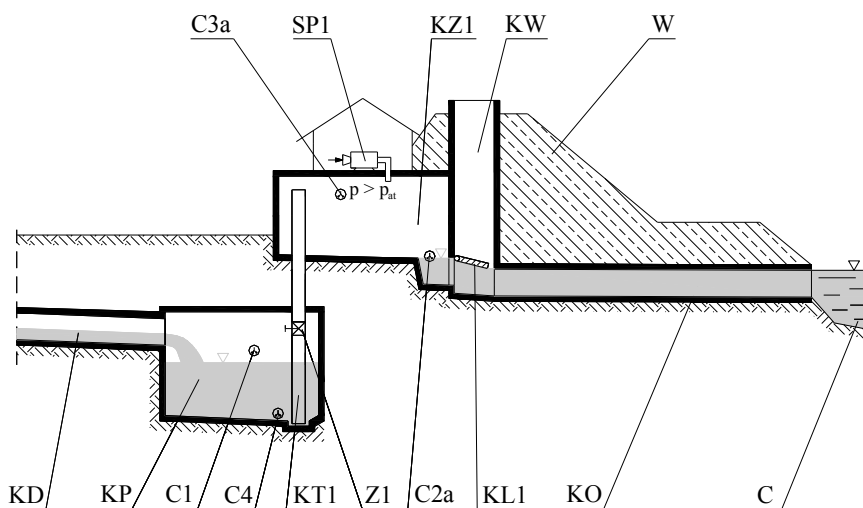

Fig. 7. Emptying the pump chamber (KZ1) to the level of the sensor (C2a) in the transfer reservoir.

## 5 Conclusions

Present solutions for stormwater transfer to water receivers used in the most of the cities of Poland are obsolete, unreliable and, apart from the extension, need urgent modernization. The unreliability of these systems is manifested primarily with frequent flooding in the sewage system in the case of elevated levels in water receivers.

With respect to the number of problems to be solved in the area of municipal investments connected with sewage disposal, it is very important and urgent that the methods of design and implementation of modern and safe solutions are developed.

Regardless of the size of the drainage basin and the used sewage system, transfer reservoirs should be viewed today as one of the most basic components in contemporary systems of the transfer of the stormwater to water receivers. Building such facilities involves considerable investments while proper operation is possible only if appropriate design and high-quality suction and pumping units are used as they consume considerable amounts of electricity to transfer the wastewater from lower to higher level or to transfer the wastewater up and to the location that ensures its gravitational outflow at the same time.

The transfer reservoir for the stormwater presented in this paper might be successfully used in modernization of current sewage systems, ensuring the reliability of operation and a more effective wastewater transfer than the systems used to date. All the reservoirs of this type are characterized by similar design and function and guarantee that the wastewater might be transferred regardless of the conditions in the water receiver. An essential feature of these reservoirs is the use of the effective method to control suction and pumping units.

Using the reservoir needs a thorough analysis of the data about the drainage basin, sewage system, equipment and facilities involved while taking into consideration minimum costs of implementation of a particular investment [9].

The design of retention and transfer reservoirs in the stormwater systems represents the basic solution in terms of the effective transport of stormwater. Adequate determination of the sufficient retention capacity is of key importance to the process of design with consideration of their effect on both reliability and costs of investment and operation. The analysis of the method of dimensioning of retention and transfer reservoirs demonstrated that the major effect on the required retention capacity is from the precipitation data used in the calculations.

Regardless of the method of dimensioning of retention and transfer reservoirs, their performance should be increased through application of the dynamic control of wastewater outflow intensity. Temporal and spatial irregularity of real precipitation offers many opportunities connected with adjustment of control equipment to the current hydraulic load of the system, both in the reservoir filling and discharge phases.

The retention and transfer reservoir presented in this study is one of the proposals for the solutions to the problem of periodical flooding of urban areas [8]. The system of air suction and pumping used in this reservoir ensures more reliable operation than the system of wastewater pumps installed since it does not go into direct contact with wastewater that contains mechanical pollutants and are often chemically aggressive. The reservoir of this type, after small adaptation, can represent the solution which is alternative to those used in the sanitary waste pumping stations.

Application of this type of the reservoirs requires an in-depth analysis of the data on drainage basin, sewage system, equipment and facilities involved so that minimization of costs of implementation of the investment is achieved.

The initial version of the design of the transfer reservoir assumed almost ideal conditions of its operation. The cycle of filling and emptying of transfer chambers necessitated maintaining balance between these processes. This involved maintaining constant value of flow rate at the inflow of wastewater to the currently filled chamber and ensuring the same or greater outflow from the emptied chamber. This was supposed to ensure that the cyclic operation of the reservoir remains undisturbed. With another approach to this problem, the times of filling and emptying the transfer chambers should be equal. Reaching such conditions in practice is impossible, thus the effect of non-cyclic operation of the chambers had to occur. With varied and lower than nominal values of rates of flow of wastewater to the reservoirs, only partial rather than complete filling of the second chamber occurs during emptying of the first one. Consequently, after decompression of the air contained in the first chamber, it is re-filled, while the other chamber remains filled partially. This is repeated until the second chamber in these stages is



filled entirely and switches in (by means of the sensor) the air compressor which empties the chamber. However, the real problem is the risk of locking the accumulation capacity of the transfer chambers. This might occur when the second chamber is filled with an insignificant volume while the process of emptying in the first chamber has already begun. In such cases, both chambers are being emptied and cannot receive wastewater to be retained. Consequently, the natural retention occurs in the reservoir inflow channel. If natural conditions allow for a safe yet short-term channel detention, causing raised filling level at the inflow, this operational mode of the transfer reservoir is acceptable.

The designed transfer reservoir can be also used to transfer the volume of wastewater from the drainage basin located higher to the basin situated at a lower level.

## Acknowledgement

This scientific study was financed within the research project BS-PB 401-306/11.

## References

1. M. Mrowiec, *Effective dimensioning and dynamic control of sewage reservoirs* (Monograph **171**, Published by University of Czestochowa, 2009) (in Polish)
2. W. Geiger, H. Dreiseitl, *New methods of draining storm water* (Projprzem, Warszawa 1999) (in Polish)
3. J. Łomotowski, *Rain water and extreme events* (Seidel-Przywecki, 2011) (in Polish)
4. W. Błaszczak, M. Roman, H. Stamatello, *Sewerage* (Arkady, Warszawa 1974) (in Polish)
5. R. Malmur, A. Kisiel, M. Mrowiec, J. Kisiel, CzT. **18**, 105, (2008)
6. M. Mrowiec, T. Kamizela, M. Kowalczyk, Environ. Prot. Eng. **35**, 2 (2009)
7. R. Malmur, Rocz. Ochr. Sr. **13** (2011)
8. R. Malmur, *The energy saving transfer reservoir in a drainage system Geminus-ET* (The Polish Patent Office, Patent No. 209453. Warszawa, 2011) (in Polish)
9. M. Mrowiec, A. Kisiel, R. Malmur, J. Kisiel, Pol. J. Environ. Stud. **16**, 2A, part III (2007)