

Obtaining sorbents from brown coals samples of Kharanorskoe coal deposit by way of electromagnetic microwave radiation exposure

Elena Vorsina^{1*}, *Tatiana Moskalenko*¹ and *Valerii Mikheev*¹

¹Mining Institute of the North, Siberian Branch, Russian Academy of Sciences, Yakutsk, Russia

Abstract. This article studies the possibility of intensification of Kharanorskoe deposit brown coal alkaline activation by way of electromagnetic microwave radiation (EMR) exposure in order to obtain sorbents. There is data that presents investigation of qualitative and adsorption properties of sorbents obtained from 0-2 mm brown coal samples impregnated with potassium hydroxide at a KOH / coal of 1 g / g weight ratio and subjected to thermolysis at 800 °C in the thermal shock mode. The authors carried out a detailed analysis of three options for thermal treatment of the coal-alkali mixture ahead of thermolysis: coal-alkali mixture drying to indistinct mass, EMR treatment and combination of ones. The design of a laboratory microwave oven for heat treatment of raw materials based on the use of EMR at a frequency of 2,450 MHz is presented. It was found out that the effect of electromagnetic microwave radiation with a frequency of 2.450 MHz makes it possible to increase the adsorption activity on iodine by 4-6%, reaching a value of 97%, to significantly shorten the time of preliminary heat treatment of the coal-alkali mixture and to shorten the thermolysis time when sorbents obtain. **Key words:** brown coal, alkaline activation, carbon sorbents, adsorption activity on iodine, electromagnetic microwave radiation.

1. Introduction

In the world practice, extensive experience in the production of sorbents from fossil coals has been accumulated. Structural peculiarity of brown coal characterized by increased voids content in comparison with hard coal and anthracites, as well as its significant explored reserves in Russia (103.11 billion tons) and a relatively low price, give priority to brown coal for its use as a precursor for the production of sorbents. Studies have shown that alkaline activation [1-7] is an effective method of obtaining sorbents from brown coal. In addition to the development of the porous structure, alkali provides a high proportion of micropores, a narrow pore size distribution and significantly reduces the ash content of the porous material through the reaction with mineral components of mineral raw materials [7].

* Corresponding author: e.worsina@yandex.ru

Experimental researches have shown that activation of brown coal from the Kharanorskoe deposit (Zabaikalsky Krai, Russia) with potassium hydroxide followed by thermolysis makes it possible to obtain carbon materials with high values on iodine adsorption activity (more than 85%) corresponding to the level of the best active carbons in the world [8, 9]. In this case, carrying out thermolysis in the thermal shock mode makes it possible to increase the adsorption activity on iodine on an average of 4% [10].

The use of electromagnetic microwave radiation (EMR) is a promising method of influencing on solid fossil fuels that allows to greatly intensify chemical-technological processes and in most cases to receive results that may not be achievable by traditional technologies [11, 12].

A lot of irrefutable advantages and unique possibilities of EMR processing in comparison with traditional heating (high process speed, volumetric heating, high coefficient of efficiency, possibility to carry out the process in the conditions of constant and pulsed energy supply, etc.) creates prerequisites for its using during process of sorbents obtaining.

There are a number of researches on the EMR influence on brown coal, including for the purpose to increase its adsorption properties [13] and technological qualities [14, 15], confirming the effectiveness of microwave radiation use. In this paper, we investigated the possibility of intensification by the EMR of the alkaline activation of brown coals from Kharanorskoe deposit in the production of sorbents.

2. Method of experimental research

As a raw material for the sorbents production, brown coal of the Kharanorskoe deposit (coal grade — B2 grade, size grade — 0-2 mm) with the following qualitative characteristics (%) was used: laboratory moisture of the sample (W_r) - 8.2; moisture of analysis sample (W^a) is 7.6; dry ash (A^d) - 7.9; volatile matter yield on dry ash free basis (V^{daf}) is 45.5; the adsorption activity on iodine (X) - 16.9.

Alkaline activation of Kharanor coal samples was carried out according to the following method. Potassium hydroxide (50% solution) was introduced into the coal by impregnation at a KOH / coal 1 g / g ratio, expressed in grams of KOH per 1 g of dry coal. The coal sample was treated with KOH, mixed manually into indiscrete mass, and held for 2 hours.

Three thermolysis preparation options of impregnated with potassium hydroxide coal (coal-alkaline mixture) were researched:

- 1 option. Drying to indiscrete mass;
- 2 option. EMR treatment without pre-drying;
- 3 option. EMR treatment with pre-drying to indiscrete mass.

The drying of the coal-alkaline mixture to a indiscrete (dry) mass was carried out in a drying chamber at a temperature profile of 105-110 °C.

Preliminary treatment of the coal-alkaline by EMR mixture was carried out in a laboratory microwave oven with a power of 900 W (Fig. 1).

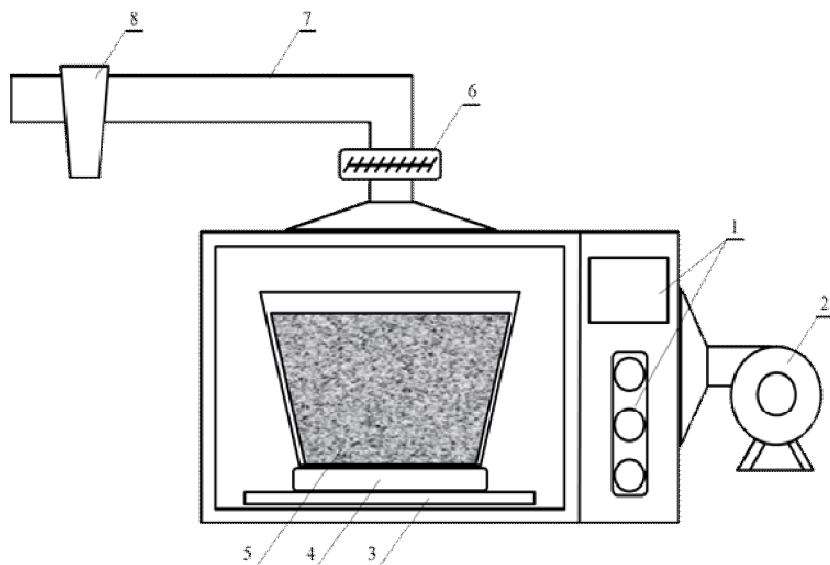

Fig. 1. Laboratory electromagnetic microwave oven scheme: 1 - operating modes indication and control unit; 2 – magnetron centrifugal cooling fan; 3 - rotary bottom; 4 - thermal insulating stand; 5 - heat-resistant glass tank for loading raw materials; 6 - gas heating main axial-flow fan; 7 - gas heating main; 8 - hydro seal

The microwave oven circuit scheme consists of an electromagnetic radiation generator (magnetron), a waveguide, a heating chamber, a magnetron ventilation and cooling system, an excess radiation protection system, a control unit [11]. A number of significant changes have been made to the design of a household in order to provide safe experimental researches using microwave oven. Installing of an additional fan strengthened magnetron ventilation and cooling system. An exhaust system consisting of a centrifugal fan and a gas heating main is installed in order to remove effectively gaseous products from the heating chamber. An additional hydro seal is installed on the gas heating main, that allows to catch the vaporous volatile matters that have produced as a result of raw materials' heat treatment.

The electromagnetic-microwave treatment of the coal-alkaline mixture was processed at a frequency of 2,450 MHz to the maximum possible temperature. In this paper, the maximum possible temperature is understood as the temperature of the coal-alkaline mixture when it reaches to an inflammation of the mixture without open fire, but with following abundant gas liberation. Put in an open laboratory glassware, a sample of the coal-alkaline mixture was placed in a microwave oven. In order to exclude the ignition of the mixture, the EMR treatment process was performed with a pulsed energy supply - 3 min for each of cycles, then the mixture was mixed, its temperature was measured and mixture was again subjected to EMR treatment.

After preliminary preparation of the coal-alkaline mixture in the above-mentioned three variants, the samples were subjected to a thermal shock at 800 °C in a muffle furnace. Isothermal aging time (t) in the investigated variants of obtaining sorbents was 15, 30 and 60 min. After the set time, the samples were taken out, cooled in air, washed from alkali using distilled water filters until a neutral washing water medium was obtained, dried to an air-dry state, and then a laboratory research of the qualitative and adsorption properties was carried out.

3. Results and discussion

The averaged schedule for the temperature set-up under the influence of EMR on the wet coal-alkaline mixture (option 2) and dried to indiscrete mass coal-alkaline mixture (option 3) is shown in Fig. 2.

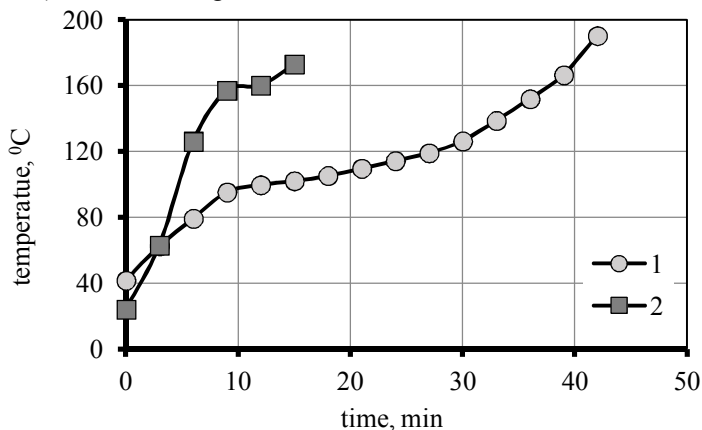

Fig. 2. Averaged schedule of temperature set-up under the influence of EMP on coal-alkaline mixture: 1 - without preliminary drying; 2 - with preliminary drying

According to Fig. 2 that in order to avoid the ignition of a wet coal-alkaline mixture, it is sufficient to apply EMR for 14 cycles (3 min each; total time - 42 min, given the time taken to mix the sample - 47 min) when the maximum possible temperature is 190-191 °C. When EMR is applied to the coal-alkaline mixture dried to indiscrete mass, its ignition begins at a temperature of 172-173 °C in 5 3-min heating cycles (15 min in total, given the mixing time - 17 min). The drying time of the sample (500 g) in the drying chamber at a temperature of 105 °C to indiscrete mass was 16-18 hours. Thus, the maximum time spent for the coal-alkaline mixture treatment was: 1 option - 18 hours; 2 option - 47 minutes (that is 23 times lower than in option 1); 3 option - 18 hours 17 minutes.

The values of the qualitative and adsorption properties, as well as the yield (Y , %) of the obtained sorbent samples are shown in Table. 1.

Analyzing the data of Table 1, it may be asserted that for all the investigated options of thermolysis preparation of samples, carbon samples with a developed porous structure were obtained, i.e. qualitative sorbents. The values of adsorption activity on iodine of the obtained sorbents samples $X > 80\%$, which corresponds to the requirements for the quality level of such active coal brands as UAF ($X \geq 70\%$) and KAD-ground ($X \geq 80\%$). In all cases the yield of the finished product was $Y > 50\%$. At the same time, the application of EMR treatment allowed to increase the sorbent yield by an average of 9.8% for all options with different isothermal aging times periods (in option 2 - by 3-21.7%, in option 3 - by 5.4-13.8%).

In the researched options of the thermolysis preparation of the coal-alkaline mixture depending on isothermal aging time, the adsorption activity by iodine scheme of the obtained sorbents is shown in Fig. 3.

Table 1. Common results of experiment

| Option | Coal-alkaline mixture thermolysis preparation | | t, min | Technical analysis rates, % | | | X, % | Y, % |
|--------|-----------------------------------------------|---------------|--------|-----------------------------|----------------|------------------|------|------|
| | Drying to indiscrete mass | EMR treatment | | W ^a | A ^d | V ^{daf} | | |
| yes | no | 15 | 11.2 | 9.6 | 59.39 | 82.2 | 59.4 | |
| | | 30 | 8.4 | 8.8 | 61.30 | 93.1 | 61.3 | |
| | | 60 | 3.6 | 8.8 | 50.06 | 90.1 | 50.1 | |
| yes | no | 15 | 4.5 | 7.5 | 55.78 | 87.0 | 61.2 | |
| | | 30 | 4.0 | 7.2 | 64.05 | 97.1 | 64.1 | |
| | | 60 | 3.5 | 9.1 | 61.01 | 95.8 | 61.0 | |
| yes | no | 15 | 11.0 | 8.8 | 65.35 | 85.0 | 65.4 | |
| | | 30 | 9.0 | 8.4 | 64.61 | 91.2 | 64.6 | |
| | | 60 | 3.4 | 9.1 | 56.97 | 97.4 | 57.0 | |

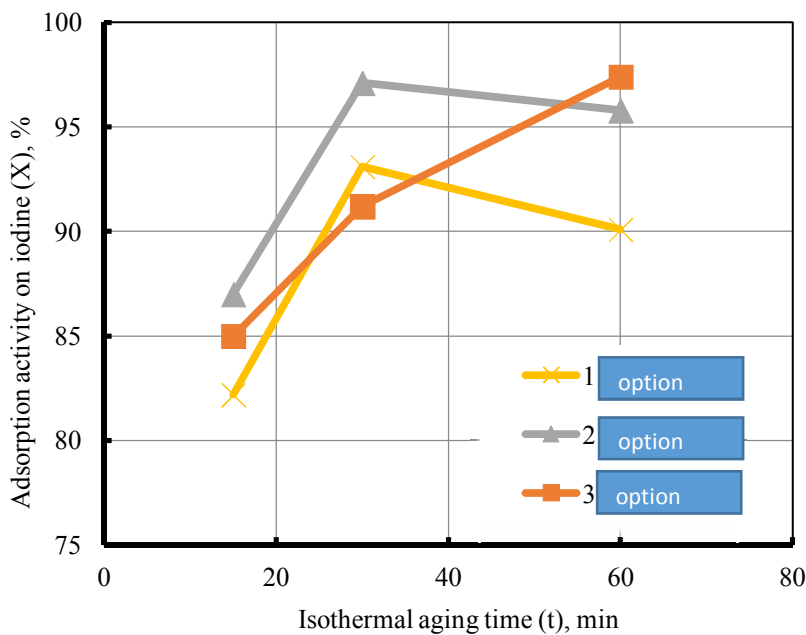

Fig. 3. Adsorption activity on iodine of the obtained sorbents samples in the researched options of thermolysis preparation of coal-alkaline mixture

Scheme demonstrates that the use of EMR treatment in option 2 in comparison with option 1 allowed to increase the adsorption activity by iodine, thus making the difference between 4-6%.

At an already short isothermal aging time of 15 min, the adsorption activity values for iodine of sorbents obtained from treated by EMR samples exceed the values of the X samples that don't subjected to such treatment: in option 2 - by 5.8%, in option 3 - by 3.4 %.

With an isothermal aging provided for 60 min, before thermolysis samples' EMR treatment allowed to increase the adsorption activity on iodine to values above 95%, while increasing the results of option 1: without coal-alkaline mixture preliminary drying (option 2) - by 6.3%, with preliminary drying (option 3) - by 8%.

At half-hourly aging of samples in a muffle furnace at 800 °C, value of the adsorption activity on iodine samples, dried to indiscrete mass and treated through EMR before thermolysis (option 3) was obtained slightly lower (by 2%) than samples not subjected to EMR (option 1), which indicates the commensurability of these values. The value of X samples under isothermal aging for 30 min and subjected to EMR without preliminary drying to indiscrete mass in options 1 and 3 for the same duration of thermolysis (option 2) exceeds the values of X and commensurate with the value of X in option 3 at 60 min isothermal aging (with a 0.3%) difference. Therefore, EMR treatment without preliminary drying (option 2) makes it possible to obtain sorbents with a high adsorption capacity on iodine (more than 95%) with significantly lower time spent for preliminary treatment (less than 23 times) and lower time spent for thermolysis (less than 2 times) of the sample directly. Thus, it is possible to exclude the energy and time-consuming drying stage of the coal-alkaline mixture to indiscrete mass from the process of obtaining the sorbents and conduct chemical activation of the brown coal from the Kharanorskoe deposit with potassium hydroxide at a KOH / coal ratio of 1 g / g for 30 minutes.

4. Conclusions

Electromagnetic radiation at a frequency of 2,450 MHz that affects on coal treated with potassium hydroxide (at a KOH / coal ratio of 1 g / g) and followed by thermolysis in the thermal shock mode at 800 °C makes it possible to obtain sorbents samples with a high yield of the final product (more than 50%) and adsorption activity on iodine 85-97%, that corresponds to the industrial-produced active coals ratio level.

Electromagnetic microwave radiation treatment allows to increase the adsorption activity on iodine by 4-6%, to shorten significantly the preliminary heat treatment time of the coal-alkaline mixture (more than 20 times) and to shorten the thermolysis time by 2 times during sorbents obtaining.

References

1. V. A. Kucherenko, T. G. Shendrik, Yu.V. Tamarkina, R. D. Mysyk, *Carbon*, **48** (15), 4556 (2010).
2. T. S. Manina, N. I. Fedorova, S. A. Semenova, Z. R. Ismagilov, *Coke and Chemistry*
3. V. M. Mukhin, A. V. Tarasov, V. N. Klushin, *Activated carbons of Russia* (Metallurgy, Moscow, 2000).
4. N. V. Chesnokov, N. M. Mikova, I. P. Ivanov, B. N. Kuznetsov, *Journal of Siberian Federal University/ Khimiya journal*, **7** (1), 42-53 (2014).

5. T. G. Shendrik, I.U. V. Tamarkina, T. V. KHabarova, Solid Fuel Chemistry journal, **5**, 51-55 (2009).
6. M. L. Shchipko, A. O. Eremina, V. V. Golovina, Journal of Siberian Federal University/ *Khimiya*, **1 (2)**, 166-180 (2008).
7. I.U. V. Tamarkina, N. N. TSyba, V. A. Kucherenko, T. G. Shendrik, Chemistry and Chemical technology journal, **3**, 132-137 (2013).
8. E. V. Vorsina, T. V. Moskalenko, V. A. Mikheev, Modern Problems of Science and Education journal, 2-3 (2015). <http://www.science-education.ru/ru/article/view?id=23990>
9. E. V. Vorsina, T. V. Moskalenko, V. A. Mikheev, Problems of Complex Development of Georesources: Mining Informational and Analytical Bulletin, **8 (21)**, 214-221 (2016).
10. E. V. Vorsina, T. V. Moskalenko, V. A. Mikheev, Geomechanical and geotechnical problems of Russian North Resources Extraction: Mining Informational and Analytical Bulletin, **11 (24)**, 146-154 (2017).
11. D. L. Rakhmankulov, I. Kh. Bikbulatov, N. S. SHulaev, S. I.U. Shavshukov, Microwave Radiation and Intensification of Chemical Processes), Moscow: Khimiya, (2003).
12. A. N. Didenko, Microwave Energetics: Theory and Practice (Nauka, Moscow, 2003).
13. O. S. Danilov, T. V. Moskalenko, V. A. Mikheev, Mining Informational and Analytical Bulletin, **3**, 203-208 (2010).
14. A. A. Khaidurova, P. N. Konovalov, N. P. Konovalov, Solid Fuel Chemistry journal, **2**, 67-70 (2008).
15. P. N. Konovalov, N. P. Konovalov, A. A. Khaidurov, Proceedings of Universities. Applied Chemistry and Biotechnology **1(12)**, 74-79 (2015).