

Gate Driver Circuit Design, PWM signal generation using FEZ Panda III and Arduino for Inverter

Srinivasa Rao D¹, Sandhya Rani MN¹, Sarfaraz Nawaz Syed² and Suresh Kumar Tummala^{3,*}

¹Assistant Professor, EEE Department, GRIET, Hyderabad

²Associate Professor, EEE Department, GRIET, Hyderabad

³Professor, EEE Department, GRIET, Hyderabad

Abstract. This paper presents the gate driver circuit design and PWM signal generation using FEZ panda III and Arduino boards for Inverter. FEZ panda III works on .net micro framework and all its programming, debugging features are available through Microsoft's Visual studio whereas Arduino features are available through Arduino software. Inverters are used in various applications like in motor drives and solar and wind power applications. This paper is commenced by basic understanding of need of gate driver circuit for inverter and different types of PWM techniques for generating gate signals for inverter. Simulation of SPWM inverter in both open loop and closed loop operation is done and its respective gate voltage waveforms are studied and later hardware implementation of gate driver circuit using TLP250H IC is carried out and gate voltages at different duty cycles is studied with the help of FEZ Panda III and Arduino boards.

1 Introduction

PWM Inverters are commonly used in variable speed ac drives. The PWM Inverter could be implemented for use in single phase and three phase types. This thesis describes the design of gate driver circuit for single phase PWM inverter using a 12-bit FEZ panda III board and 8-bit Arduino controller. The basic inverter design approach is to convert the line voltage to DC as input to the inverter, a gate driver circuit to switch on the IGBT's and controller to generate required gating signals. A potentiometer can be used to vary the duty cycle of the pulses generated

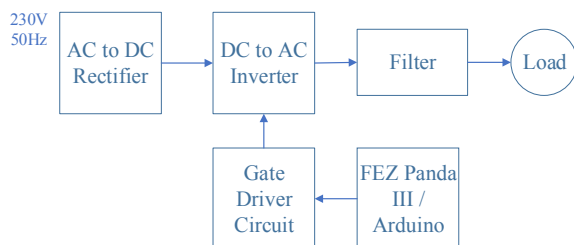

Fig. 1. Block diagram

The basic block diagram of this paper is shown in the figure. The overview of the paper is given through this block diagram. A rectifier, inverter, filter, gate driver circuit, microcontroller and load are the components used. Power supply for the inverter is given by the rectified dc supply from rectifier. The gate pulses required for the inverter to operate are generated from

the microcontroller and then given to gate driver circuit. The gate voltage is checked at different duty cycles

2 PWM Inverter

Inverter is basically a circuit which converts electrical energy in DC form to AC form. Inverters usually work on Pulse Width Modulation (PWM) technique. PWM is a technique in which the width of the gate pulses are controlled by various mechanisms which is used to keep the output voltage of the inverter at the rated voltage irrespective of the load.

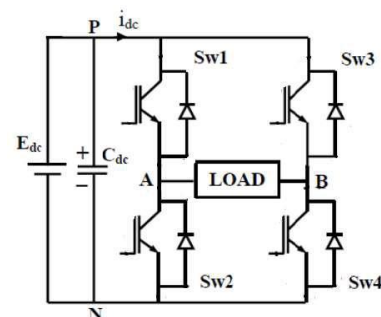

Fig. 2. PWM Inverter

The gating signals for Inverter are generated using microcontroller and a gate driver circuit is needed for switching purpose. First different PWM techniques were studied and later simulation of SPWM single phase inverter is done in which gating signals were observed and then hardware implementation is carried out.

* Corresponding author: sureshkumar.t@griet.ac.in

3 SPWM Technique

Out of many PWM techniques SPWM is the most commonly used method. Gating pulses are generated by comparing the reference signal with the carrier wave form. In this method sinusoidal waveform is taken as the reference signal and triangular waveform is the carrier waveform. Gating pulses are generated whenever sine wave value is higher than the triangular wave value. The width of the pulses are not equal because the reference signal is sinusoidal waveform. The gate pulse generation is shown in the figure below.

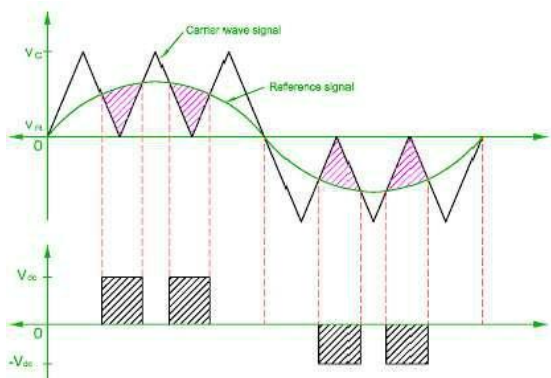

Fig. 3. Sinusoidal pulse width modulation pulses

The duty cycle of the gate pulses is varied which is given by the amplitude modulation ratio m_a .

$$m_a = \frac{V_{ref}}{V_{carrier}}$$

If $m_a > 1$ it is over modulation
 If $m_a < 1$ it is under modulation

The output of the SPWM inverter is given by

$$V_o = V_s \sqrt{\frac{p\delta}{\pi}}$$

Where p = number of pulses

4 Simulation

In this section simulation of single phase inverter using SPWM technique is described and here induction motor is used as load on which open loop operation is performed

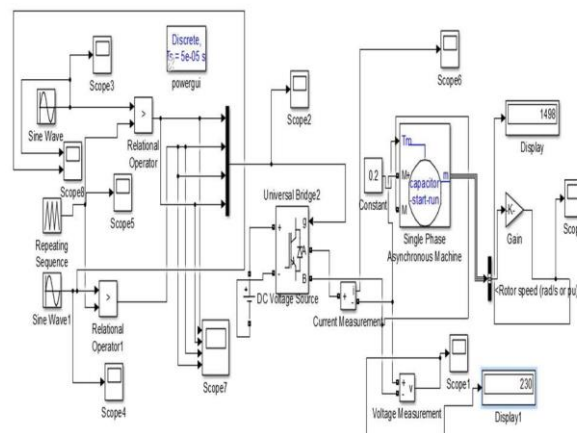

Fig. 4. Simulation diagram of single phase inverter

In Figure 4 Simulink diagram of single phase inverter with induction motor as load is shown.

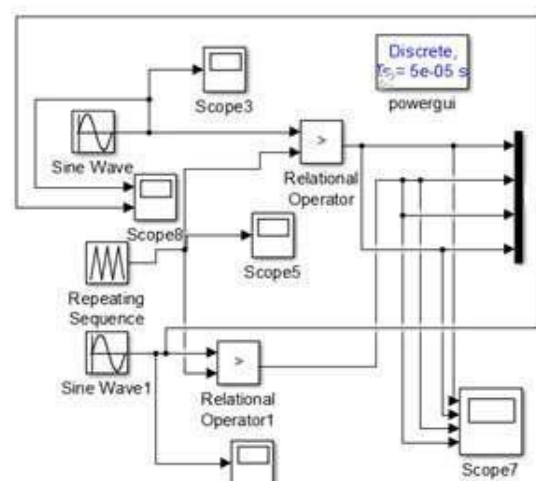

Fig. 5. Sinusoidal pulse width modulation

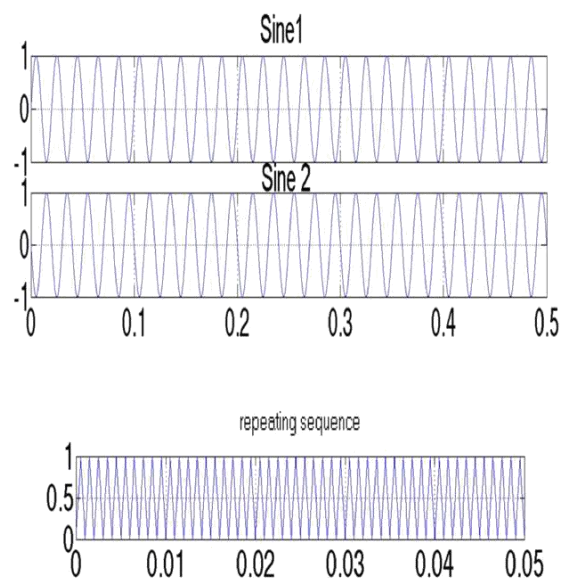

Fig. 6. SPWM Technique

The PWM technique used here sinusoidal pulse width modulation. In this technique two sine waves 180° out of

phase are taken as reference signal and a repeating sequence block is taken as carrier signal. The signals from these two blocks are compared using a relational operator block of greater than logic and the required gate signals are produced whenever the amplitude of sine wave is greater than triangular wave for the operation of single phase inverter. The obtained gate pulses are shown in the Fig. 6.

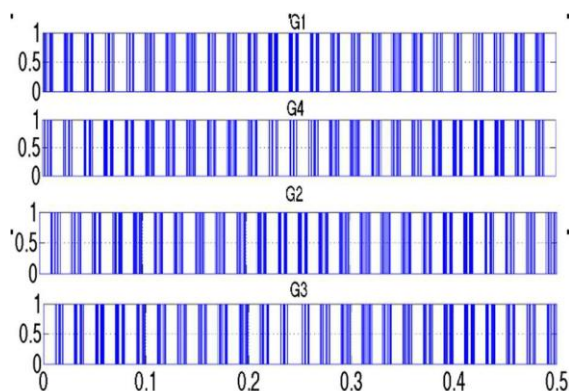

Fig. 7. Gate Pulses

5 Controller

In this chapter the controllers used in this project are discussed i.e. Arduino and FEZ Panda III controller.

A. Arduino

Arduino is an 8-bit microcontroller board based on ATmega348. It works on C programming language. It has 6 PWM pins.

B. FEZ Panda III

FEZ panda is a small low cost single board computer which runs on .net micro framework a tiny version of Microsoft .net framework. All the programming and debugging features are available through the visual studio allowing C# over a simple USB or serial communication. It has 51 IO and 21 PWM pins

6 Gate Driver Circuit

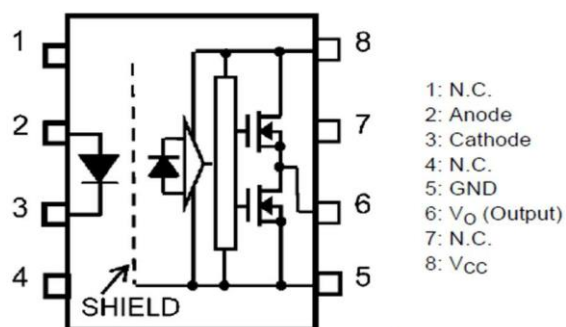

Fig. 8. Pin diagram of TLP250H

Power semiconductor devices have special requirements when it comes to switching which is fulfilled with the help of gate driver circuit. Generally micro controllers generate PWM signals of very low range which is not sufficient for the switches to turn on so a gate driver

circuit is designed for that purpose. In this paper TLP250H IC is used for this purpose which is shown in the figure 8.

TLP250H photocoupler basically has a totem pole configuration. Gate driver IC is basically a half bridge with a common input and IGBT gate acts as a capacitor which needs to be charged up for switching. It has half bridge configuration at the top right, opto isolator in middle and LED at top left which activates the photo emitting device which in turn activates half bridge providing required gate voltage.

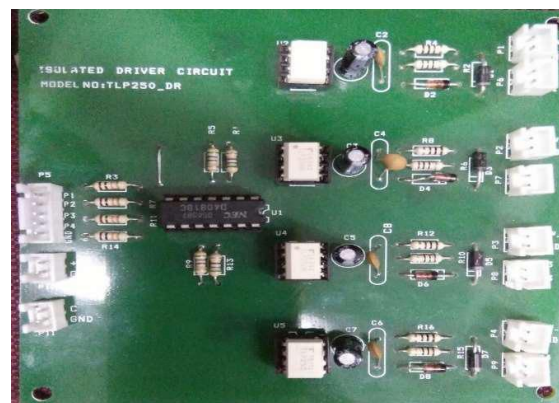

Fig. 9. Gate Driver Circuit

7 Results

The results obtained are shown in the below sections

A. Gate pulses

Gate PWM pulses are generated using both Arduino and FEZ Panda III controller.

Program flowchart

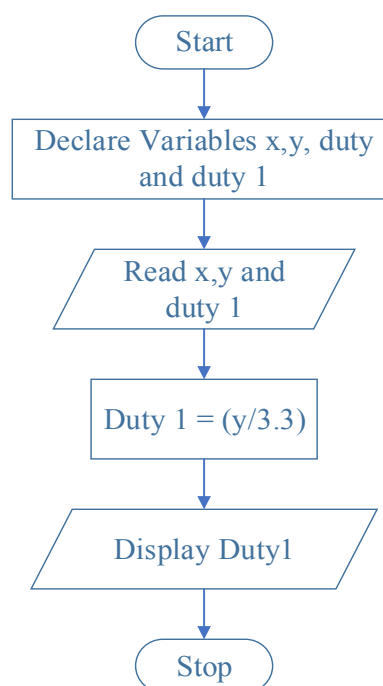

Fig. 10. Flow chart

Pulses generated using Arduino

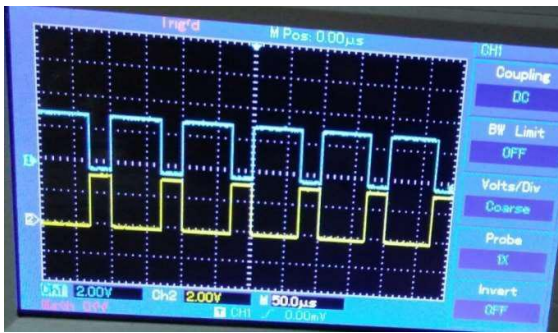

Fig. 11. Gate Pulses generated using Arduino

Pulses generated using FEZ Panda III

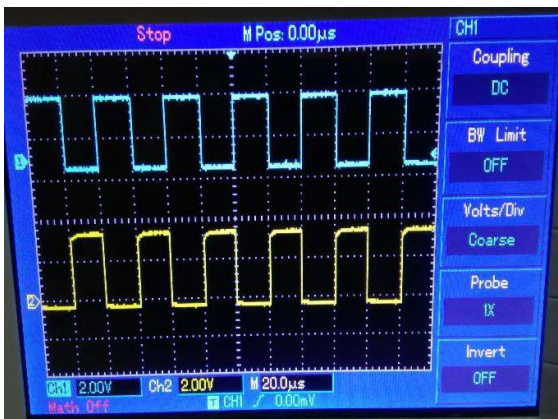

Fig. 12. Gate pulses generated using FEZ Panda III

Gate Voltage

PWM pulses are obtained at different duty cycles by varying potentiometer

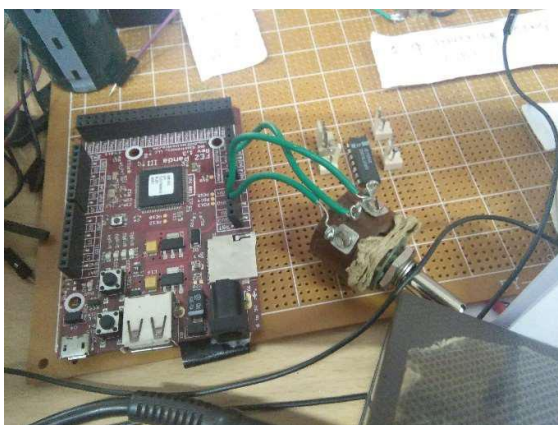

Fig. 13. FEZ Panda III with potentiometer

Potentiometer is used for varying the duty cycle of the gate pulses. It consists of three terminals one for supply, other for ground and the third terminal to the analog input of the micro controller used. A program is written in such a way that as we vary the value of this potentiometer duty cycle of the PWM pulse generated changes. 3.3V or 5V of the microcontroller is used as supply for this.

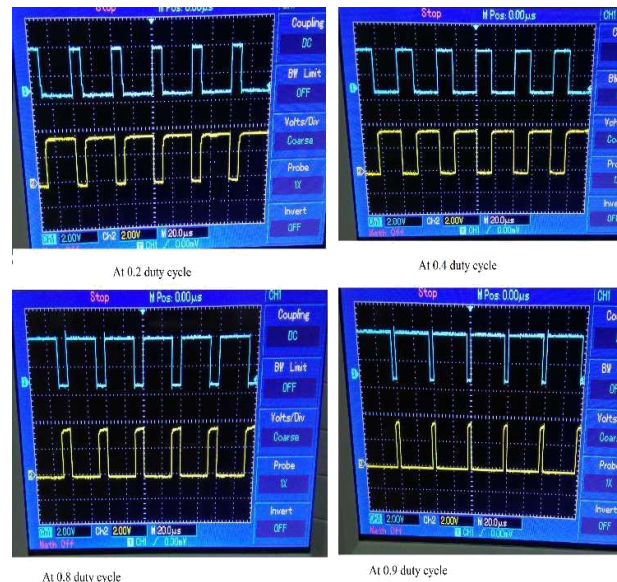

Fig. 14. Pulses at different duty cycles

8 Conclusions

Single phase PWM Inverter is designed using IGBT switches and the gate signals are generated using FEZ Panda- III and Arduino microcontroller boards. The required gate driver circuit for switching IGBT switches is designed using TLP250H IC. The simulation of sinusoidal pulse width modulation (SPWM) inverter is performed and the respective gate voltages is observed and hardware implementation is carried out using gate driver circuit and gate voltages at different duty cycle are obtained using FEZ Panda III and Arduino boards

References

1. Induction Motor speed control using IGBT's and constant V/F method, Department of Electrical & Electronics Engineering, P.D.A. College of Engineering, Gulbarga, Karnataka, India.
2. Microcontroller based PWM inverter for speed control of an Induction motor, Department of Electrical and Electronics Engineering, BUET, Dhaka, Bangladesh.
3. Speed control of Induction motor using PWM Technique, Department of Electronics and Telecommunication Engineering, Dr. Daulatrao Ahir College of Engineering, Maharashtra, India
4. L. Vinod Kumar and Syed Sarfaraz Nawaz, "Design and Implementation of Inverter System to Drive Induction Motor using DSPACE" International Journal for Research in Applied Science & Engineering Technology (IJRASET) Volume 4 Issue XI, November (2016), ISSN: 2321-9653
5. Power Electronics by Dr. P.S. Bimbhra. Khanna Publishers, New Delhi