

# Communication between PHEV's and Smart Grid using Zigbee Protocol

Karthik Rao R<sup>1,\*</sup>, Sai kiran P<sup>2,\*</sup>, and Phaneendra Babu Bobba<sup>3</sup>

<sup>1,2,3</sup>Department of Electrical Engineering, GRIET, Hyderabad, India

**Abstract.** Plug-in-hybrid electric vehicles commonly known as PHEV's are hybrid electric vehicles that use rechargeable batteries for operation. Since PHEV's run on electric batteries, they require charging after the charge reaches a certain minimum level. The batteries can be charged using external sources usually a smart grid. This requires a wireless technology that can be used to send the information of the battery charge to the smart grid so that it can be charged. This paper is a detailed description of how this communication can be achieved using the ZigBee wireless technology. The battery level information can be sent to the smart grid using this technology and the smart grid operator can then decide whether the PHEV needs charging or not. If not, the battery can be used to provide Vehicle-to-grid (V2G) services i.e. the charge from the vehicle can be sent back to the grid depending on the will of the vehicle owner. Thus, in this way a system can be developed where in both the PHEV driver and the grid operator can benefit.

## 1 Introduction

Plug-in-hybrid electric vehicles commonly known as PHEV's are hybrid electric vehicles that use rechargeable batteries for operation that can be charged using an external power source. This external power source can be a smart grid. PHEV's draw energy from the smart grid and use it to supply propulsive energy to the vehicle. While the conventional hybrid vehicles used petroleum/diesel for propulsive energy, PHEV's are a step forward and use electric current to achieve the necessary propulsion. PHEV's are seen as an important alternative to the conventional hybrid vehicle because they will reduce dependence on petrol and diesel as well as reduce carbon dioxide emissions associated with the burning of fossil fuels. Therefore, PHEV'S are not only sustainable but also environmental friendly.

PHEV's consist of a gasoline or diesel engine with an electric motor and a large rechargeable battery which can be charged from an outlet. When the battery of the PHEV is emptied, the conventional gasoline engine turns on and the vehicle starts operating as a non-plug-in hybrid. PHEV's produce significantly less carbon dioxide emissions than their gas only counterparts. The efficiency of the PHEV's is extremely high due to the presence of an electric motor and a battery. The cost of a PHEV's is less due to use of less gas as compared to their gas only counterparts. The PHEV's work in two modes:- 1) All-Electric mode and 2) Hybrid mode. In all-electric mode, the electric motor and the rechargeable battery provide all the propulsive needs of the vehicle. The PHEV's continue to run in the all-electric mode until their battery charge is depleted. Usually, the batteries are able to provide

propulsive energy up to 40 miles after which they require to be charged.

In the hybrid mode, both the motor and the gasoline are used. The PHEV battery needs to be continuously recharged in order for it to fulfil the propulsive needs of the vehicle. While the smart grid can essentially supply energy to the car battery to charge it, there is a possibility of reverse flow of energy i.e. from the battery to the grid when the electric vehicle is not in use such as during the night time or early mornings. This gives rise to the possibility of two types of power interactions when the electric vehicle battery comes in contact with the smart grid. These are Grid-to-vehicle (G2V) and Vehicle-to-grid (V2G) types of power interactions. The V2G is a new concept which is currently practiced in a selected few countries. Its proper implementation requires the development of communication architecture as well as an efficient technology (wired or wireless) that can transmit the battery information to the smart grid operator. Two types of V2G architectures have been developed. These are the Direct-deterministic model and the Aggregative model. [1-4]

## 2 V2G Architectures:overview

### 2.1 Direct deterministic architecture

\* Corresponding author: [r.karthikrao427@gmail.com](mailto:r.karthikrao427@gmail.com), [saikiran170897@gmail.com](mailto:saikiran170897@gmail.com)

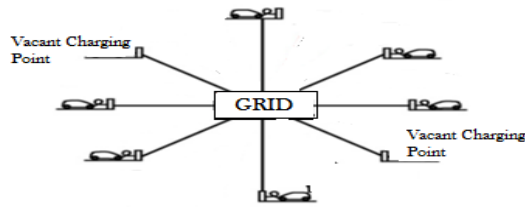

Fig 1. Vehicles under Direct deterministic architecture[4]

In this type of architecture, a direct line of communication exists between the grid system operator and the vehicle owner such that the vehicle acts as a deterministic resource which acts according to the commands of the grid operator. The vehicle can provide ancillary services till the time it is at the charging station i.e. till the time it is connected to the charging outlet.

### 2.2 Aggregative architecture

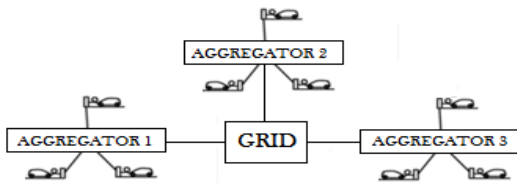

Fig. 2. Vehicles under Aggregative architecture [4]

Aggregative architecture aggregates the vehicles to make a single controllable power source. In this architecture, an intermediary is inserted between the smart grid operator and the vehicles performing ancillary services. The aggregator receives ancillary service requests from the grid system operator which issues the power commands to the vehicles that are available at the station. The aggregator can modify the power commands to the vehicles based on the number of vehicles present at the charging station. Thus even if the number of vehicles at the station is less, the aggregator can still provide the ancillary services to the grid by modifying the power commands issued to the available vehicles.

During V2G power interactions, two primary stakeholders are involved- the vehicle owner and the grid system operator. The V2G architecture under consideration should satisfy the demands of both. Due to this reason, the two architectures mentioned above are compared on the basis of three factors viz Availability, Reliability and Compensation.

### 3 V2G Architectures: a study availability of v2g architecture

The availability of the architecture is calculated using the Availability factor which is defined as the ability of an individual generation resource to enter into a contract with the grid system operator. It can be calculated as:

$$AF = \frac{\text{Number of hours of service}}{\text{Total number of hours of operation}} \quad (1)$$

The availability factor is then compared with the availability of the gas turbine power plant which is the conventional ancillary service provider to the grid. Its availability is found to be 92.91%.

#### 3.1.1 Availability of Direct deterministic architecture

The availability of the direct deterministic architecture can be calculated by considering two scenarios during which the vehicles can take part in V2G services. These are V2G from home scenario i.e. vehicles providing services when they are parked at home and V2G from home and work scenario i.e. vehicles providing services when they are parked at either home or workplace. A graph is plotted between the minute-by-minute availability of an average vehicle (*Avehicle*) using the NHTS dataset and the time for both the scenarios.

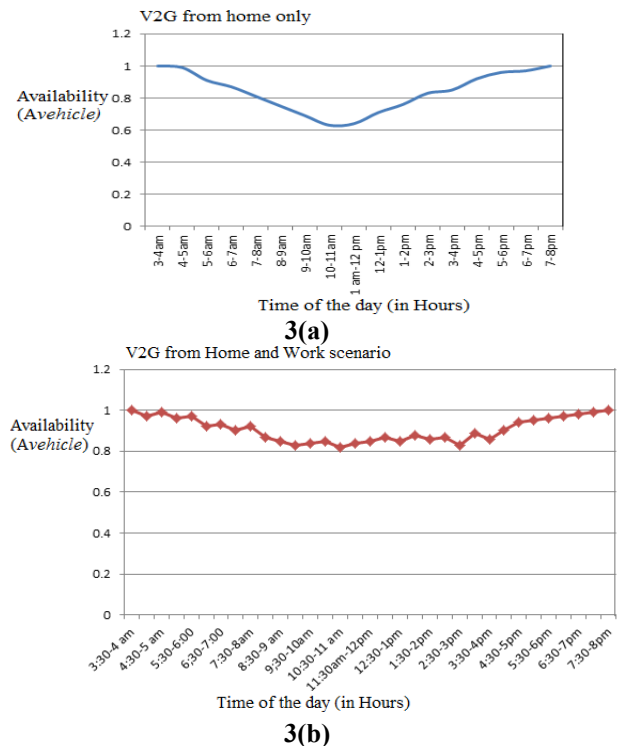

Fig 3(a) and 3(b). Graphs for V2G from home and V2G from work and home scenarios.

It is observed that the availability of the vehicles is Maximum during the early morning hours for both the scenarios but decreases gradually as the day progresses. However, in case of the work and home scenario the availability is improved due to the ability of the vehicle to take part in V2G services from the workspace also which increases the charge penetration and therefore increases its availability.

### 3.1.2 Availability of vehicles under Aggregative architecture

In case of the aggregative architecture, the ability of the grid operator to enter into a contract with the vehicle owner is independent of the availability of the vehicle at the charging station due to the presence of an aggregator in between. The aggregator receives power commands from the grid operator. It modifies the power commands for each vehicle depending upon their number. Thus, even if the number of vehicles at the charging station is low, the aggregator is still capable of sending some energy back to the grid due to which the availability of aggregative architecture approaches 100% which is greater than that of the conventional gas turbine power plant. Therefore, the aggregative architecture provides greater benefits to the grid operator due to the larger availability of the vehicles.

### 3.2 Reliability of V2G architecture

The reliability of a power plant is calculated by its ability to fulfil a V2G ancillary service contract even during its forced down time. The reliability of a V2G service provider is calculated by a factor called the Forced Derated Hours Ratio (FDHR). The FDHR is defined as the ratio of the Equivalent Forced Derated Hours (EFDH) to the Service Hours (SH) i.e.

$$FDHR = \frac{EFDH}{SH} \text{-----} (2)$$

The reliability of a system to provide the contracted and commanded ancillary services is calculated as:-  
 Reliability,

$$R = (1 - FDHR) \text{-----} (3)$$

The reliability of the V2G service provider under consideration is compared with the reliability of the gas turbine power plants which are the conventional ancillary service provider to the grid which is found to be:-  
 FDHR=1.11%

Therefore,  $R = 1 - 0.011 = 98.9\%$

Thus the reliability of the gas turbine power plant is found to be 98.89%.

#### 3.2.1 Reliability of vehicle under Direct deterministic architecture

Under Direct deterministic architecture, the FDHR of the vehicles is found to be 4.65% for the home connection scenario and 5.13% for the home and work connection scenario. The reliability thus becomes 95.35% for the home connection scenario and 94.87% for the home and work connection scenario. In both the cases, the direct deterministic architecture is unable to meet the industry standards reliability of 98.89%.

#### 3.2.1.1 Reliability of vehicles under Aggregative architecture

The reliability of the aggregative architecture is found by calculating the total fleet size (Nvehicles) which allows the aggregator to fulfil an hourly contract for a certain power. The fleet scaling factor xfleet is determined as follows:-

$$xfleet = \frac{\ln(1-R)}{\ln(1-AF)} \text{-----} (4)$$

Where R is the reliability of the baseline gas turbine generator and AF is the availability factor.

- For the home connection scenario, Availability Factor=83.6, R=98.89%. Therefore, xfleet=2.49.
- For the home and work connection scenario, Availability Factor=91.7%, R=98.89%. Therefore, xfleet=1.81.

Using the fleet scaling factor the amount of power contracted by the aggregator (PNvehicles) can be calculated as follows:

$$\frac{PNVEHICLES}{XFLEET} \text{-----} (5)$$

By increasing the size of the aggregator's vehicle fleet, the reliability can be increased to match the industry standards.

### 3.3 Compensation from V2G architectures

Compensation is the potential revenue earned by the vehicle owner for taking part in the V2G ancillary services. The vehicle owners will take part in V2G services only if they are given a good compensation for their investment.

The revenue earned is calculated as the  
 Average Annual Gross Profit=

$$AAGP = [rReg_{up} + rReg_{down} - cReg_{up} - cReg_{down}] \text{-----} (6)$$

Where,

$rReg_{up}$  = Revenue earned for regulation up service

$rReg_{down}$  = Revenue earned for regulation down service

$cReg_{up}$  = Cost for a single regulation up contract

$cReg_{down}$  = Cost for a single regulation down contract

The compensation received by the vehicle owners for taking part in V2G ancillary services for the two

architectures is compared.

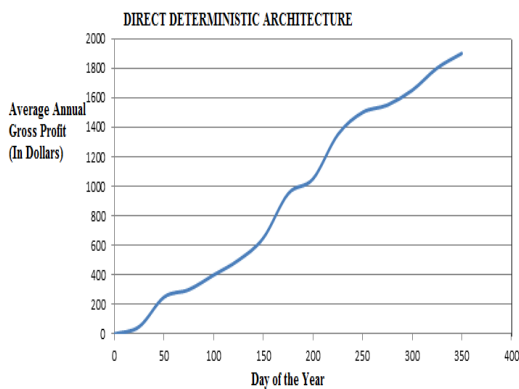

**Fig.4.** Revenue earned by vehicles for taking part in V2G services under direct deterministic services

It is observed from the graphs that for the same day of the year, the revenue earned under direct deterministic architecture is more than the earned revenue under aggregative architecture. This is because the fleet size increases in an aggregative architecture as more vehicles come to the charging station but the revenue earned by the aggregator (intermediary) for its services to the grid system remains the same which is to be divided equally among all the vehicles connected to the aggregator thereby reducing the amount received by the individual vehicle.

Thus, it can be concluded that from the point of the view of the vehicle owner, the direct deterministic architecture is more beneficial than the aggregative architecture.

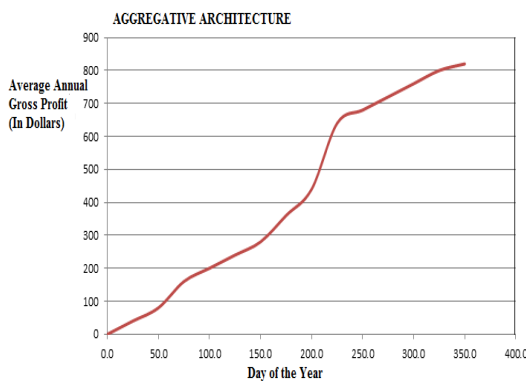
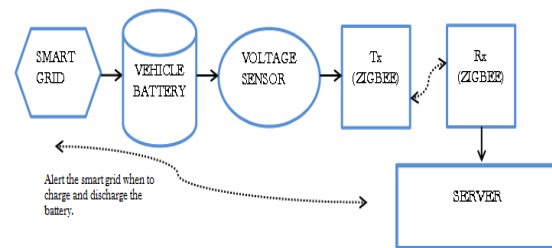

**Fig.5.** Revenue earned by vehicles for taking part in V2G services under aggregative architecture

## 4 Establishment of communication using ZIGBEE

Communication plays an important role in sending information to and from the vehicle. The type of communication technology that can be used to transmit information (battery level) can be either wired or wireless. Here, the ZigBee wireless technology which belongs to the IEEE 802.15.4 standard has been used. The following

block diagram shows the communication between the vehicle battery and the server.



**Fig.6.** Communication from the vehicle battery to the server.

## 4.1 Working

The battery of the vehicle is connected to a charging outlet which is connected to the smart grid. A voltage sensor is connected to the battery to sense the amount of charge present in it. The voltage sensor measures the voltage value of the battery and sends the information to the servers wirelessly. The wireless communication is achieved using the Zigbee transceivers. The voltage value is received at the receiving station which is the smart grid operator where its value is analysed and it is decided whether it can take part in V2G ancillary services or not. The various steps involved in the one-way communication as shown in the block diagram are briefed as follows:-

The voltage of the battery is measured by a voltage sensor. The output of the voltage sensor is sent to the QPSK modulator after converting it in the form of bits. After modulation, the modulated information is sent to the demodulator through a ZigBee transceiver and the information is received by another transceiver which sends it to the QPSK demodulator. The demodulator then sends the information to the server where it is analysed. If the value of the charge is less than a certain minimum value (which is predefined in the smart grid's computer system) then the battery is put on the charging mode and if the value is more, the battery can take part in V2G ancillary services depending on the will of the vehicle owner. [5-7]

## 5 Software implementation using simulink

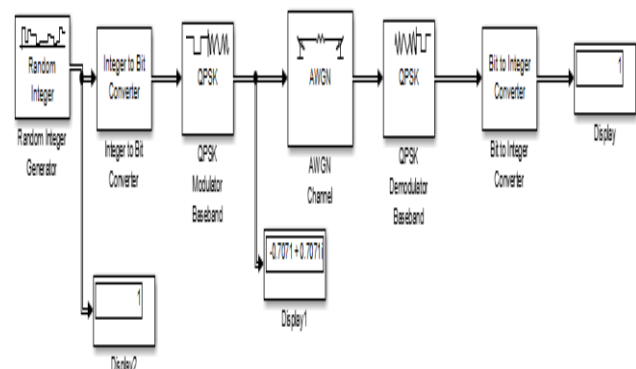

**Fig.7.** Matlab simulation of one way communication between the vehicle battery and server.

### 5.1 Working

The Random Integer Generator represents the voltage levels in the battery, Integer to Bit converter is Analog to Digital Converter because the input to the QPSK Modulator and Demodulator block should be in the form of bits, AWGN (Additive White Gaussian Noise) is the wireless channel through which the data is transmitted, the display block is used to show the received voltage levels of the battery. In the model, the Random Integer Generator block represents the battery of a car which has voltage and display block represents the server which gets the information about the battery of the car. As the Random Integer Generator takes the integer values the input from time to time, the same value is being displayed on the Display block by passing through the various blocks in the Simulink. To be more precise, Random Integer Generator takes one integer at a time and transmits it to the integer to bit converter block which acts as Analog to Digital Converter from which the converted data is being given to QPSK modulator block in the form of bits where it is wirelessly transmitted over a wireless channel to the QPSK demodulator block where it is transmitted to Bit to Integer Converter block which acts a Digital to Analog Converter before finally getting displayed on the Display block which is the sever. The same is being implemented using hardware but in a slightly different manner.

## 6 Hardware implementation

The model is implemented using the following hardware components.

1. Arduino boards
2. ZigBee transceiver modules
3. A voltage sensor
4. Jumper wires
5. X-CTU software
6. Arduino software
7. DC power supply

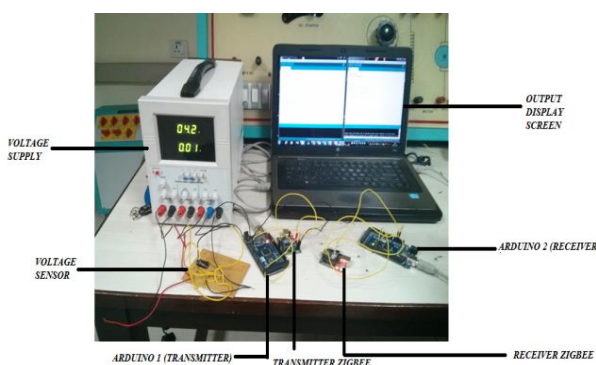

**Fig 8.** Experimental Setup using Hardware components

## 6.1 Construction of voltage sensor circuit

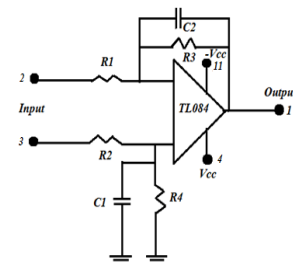

**Fig.9.** Voltage sensor using TL084 IC

Where  $R1=R2=10\text{ k}\Omega$ ,  $R3=2.2\text{ k}\Omega$ ,  $R4=2.2\text{ k}\Omega$ ,  $C1=C2=103\text{ pF}$

The first step to achieving the one-way communication is the development of a voltage sensor circuit whose output is given as an input to the transmitter. TL084 IC is used in the voltage sensor circuit. The voltage sensor circuit de-amplifies the magnitude of the input voltage. The output voltage at pin 1 after de-amplification is given by the formula:-

$$V_o = \frac{R_f}{R_i} * V_{in} = \frac{R_3}{R_1} * V_{in} \text{----- (7)}$$

Where  $V_o$ =Output voltage at pin 1,  $V_{in}$ =Input voltage. Thus, if the input voltage is 5V, it gets de-amplified to 1.1V and is shown as the output at pin no 1. During the hardware implementation, the output of the voltage sensor is connected to the 'A0' pin of the transmitting Arduino.

## 6.2 Testing of ZigBee transceiver modules

Before using the ZigBee transceiver modules, it is imperative to check whether they work properly or not. This can be done by checking whether the two Zigbees communicate with each other or not. For this, the XCTU software can be used where the communication between modules is tested by assigning different modes to each module also called as the configuration of modules. The ZigBee module acting as the sender is assigned the router mode and ZigBee module acting as the receiver is assigned the coordinator mode. One of the ZigBee transceiver modules is connected to computer through USB cable and assigned the router mode after which the other Zigbee is connected to the same computer and assigned the coordinator mode. The result of the communication test can be seen on the console log. In the console window of the transmitter, we write something (let's say 'hello world'). If the Zigbees are working and communicating, then this 'hello world' would appear on the console log screen of the receiver screen as well.





**Fig.10.** ‘Hello World’ written on Transmitter Console log screen.

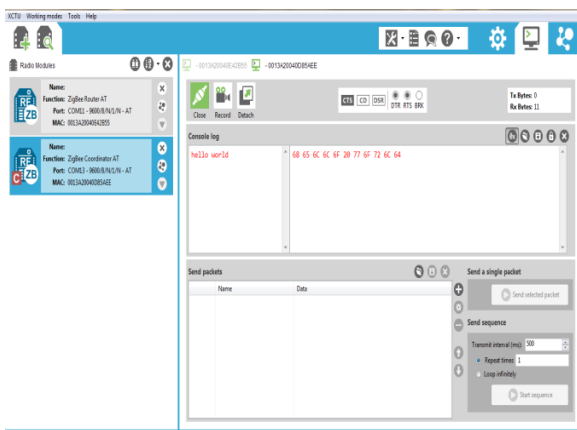
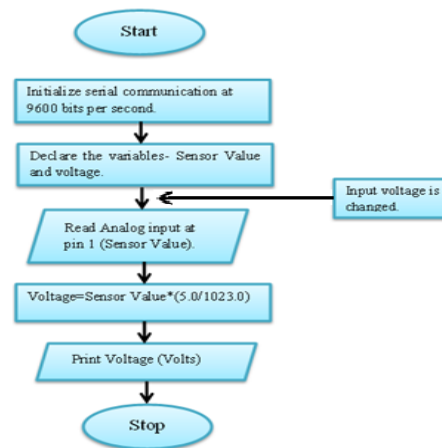

**Fig 11.** ‘Hello World’ appears on Receiver Console log screen.

### 6.3 Connecting the ZigBees to Arduino boards

Once the ZigBee transceivers are tested, they are disconnected from the computer and connected to the Arduino boards. The Arduino boards are then connected to computer through the USB cables. The connections between Arduino board and ZigBee modules differ for the transmitter and receiver. For the transmitter, 5 V of Arduino board is connected to 3.3 V of ZigBee, GNDs of Arduino board and ZigBee are connected, T<sub>0</sub> of Arduino board is connected to Din of ZigBee module and R<sub>0</sub> of Arduino board is connected to Dout of the ZigBee module. For the receiver, 5 V of Arduino board is connected to 3.3 V of ZigBee, GNDs of Arduino board and ZigBee are connected, R<sub>0</sub> of Arduino board is connected to Din of the Zigbee and T<sub>0</sub> of the Arduino board is connected to the Dout of the Zigbee module. After making the connections, the Arduino is connected to the laptop. The transmitter and the receiver programs are uploaded on the respective Arduinos (it is to be noted that while uploading the program on the Arduino, it should not be connected to the Zigbee). For compiling and uploading the programs on the Arduinos, the ‘Arduino’

software is used. Once the transmitter and the receiver programs are uploaded, the output can be observed on the receiving Arduino’s serial monitor screen.



**Fig 12.** Flowchart showing the transmitter side program

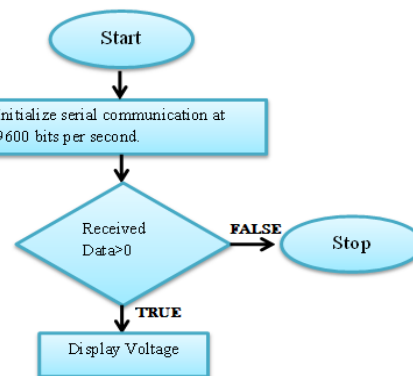

**Fig 13.** Flowchart showing the receiver side program.

### 6.4 Transmitter and Receiver Programs

The output of the voltage sensor (which carries the information about the battery level) which is transmitted wirelessly needs to be displayed on the receiving Arduino’s serial monitor screen. For this, certain programs have to be uploaded on the transmitting and the receiving Arduinos. The flow chart describing the functions of the programs uploaded on the transmitter and the receiver are shown below.

### 6.5 Output

For the battery input=4.3V, the voltage sensor output becomes:

$$V_o = \frac{2.2 \times 4.3}{10} = 0.946V$$

This value is wirelessly transmitted from the transmitter to the receiver which can be viewed on the serial monitor screen of the receiving Arduino.

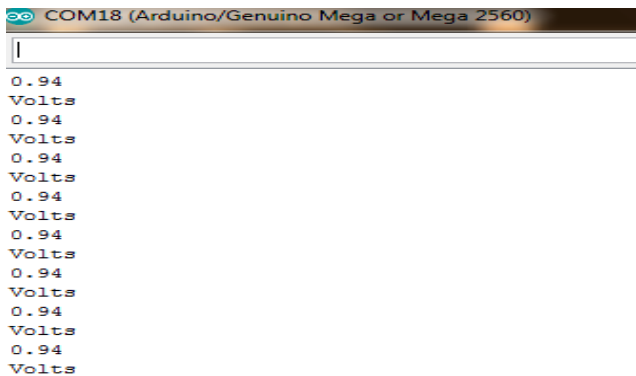

```
COM18 (Arduino/Genuino Mega or Mega 2560)
|
0.94
Volts
0.94
Volts
0.94
Volts
0.94
Volts
0.94
Volts
0.94
Volts
0.94
Volts
0.94
Volts
0.94
Volts
```

**Fig 14.** Output of the voltage sensor as seen on the Serial monitor screen of the transmitting Arduino.

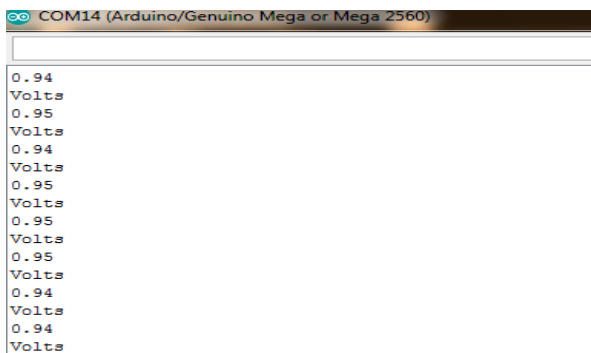

```
COM14 (Arduino/Genuino Mega or Mega 2560)
|
0.94
Volts
0.95
Volts
0.94
Volts
0.95
Volts
0.95
Volts
0.94
Volts
0.94
Volts
```

**Fig 15.** Serial monitor screen of the Receiving Arduino showing the wirelessly received value.

## 7 Conclusion

In this paper, various architectures to make Vehicle-to-grid type of power interaction a reality are discussed. The architectures should be such that they meet the interests of both the stakeholders involved in this process i.e. the vehicle owner and the grid system operator. For this, the architectures are compared on the basis of three factors namely-Availability, Reliability and Compensation to find out which of the two is able to meet the demands of both the stakeholders and provides greater benefits. In the later sections, the Zigbee wireless technology is used to demonstrate one-way communication between the vehicle and the server using a voltage sensor as the battery's voltage sensor, the Zigbee transceivers and the Arduinos.

## References

1. Colak, Ilhami, et al. "A survey on the critical issues in smart grid technologies." *Renewable and Sustainable Energy Reviews* 54 (2016): 396-405.
2. Palak P Parikh, Mitalkumar G Kanabar, and Tarlochan S. Sidhu, "Opportunities and challenges of wireless communication technologies for smart grid applications", *Power and Energy Society General Meeting*, 2010 IEEE.
3. Kabisch, Sebastian, et al. "Interconnections and communications of electric vehicles and smart grids", *Smart Grid Communications (SmartGridComm)*, 2010 First IEEE International Conference on IEEE, 2010.
4. Yan, Ye, et al. "A survey on smart grid communication infrastructures: Motivations, requirements and challenges." *Communications Surveys & Tutorials*, IEEE 15.1 (2013): 5-20.
5. Casey Quinn, Daniel Zimmerle and Thomas H. Bradley, "The effect of communication architecture on the availability, reliability, and economics of plug-in hybrid electric vehicle-to-grid ancillary services", *Journal of Power Sources* 195.5 (2010): 1500-1509.
6. SaidaElyengui, RiadhBouhouchi and TaharEzzedine, "The Enhancement of Communication Technologies and Networks for Smart Grid Applications", *International Journal of Emerging Trends & Technology in Computer Science (IJETTCS)*, November – December 2013
7. Piyush Ghune, Ruchita N Ghune, Pawan Pandey and Pushpendra Mishra, "Applications of Wireless Sensor Networks and Smart Grid-Opportunities, Challenges and Technologies Available (A Survey)".