

Ground parameters of working standard of reproduction of small speeds of air stream

Mykhailo Dudnyk^{1,*}, *Viktor Veretennyk*¹, *Serhii Enhel*¹, *Vadym Krytskyi*¹, and *Vadym Myroshnychenko*²

¹Institute of Geotechnical Mechanics named by N. Poljakov of National Academy of Sciences of Ukraine, 49005, Dnipro, Simferopolska Str., 2a, Ukraine

²DTEK, 01032, Kyiv, Lva Tolstoho Str., 57, Ukraine

Abstract. As a working standard for research in the area the lowest air velocity can be used a rotary stand. In Ukraine it was not standard measuring instruments of low speeds of air flow. Used Ukrmetrteststandart the Pito-Prandl model pressure tube has a precision class of 0.5, but the range of measurements start only with 5 m/s. In the Institute of Geotechnical Mechanics named by N. Poljakov of National Academy of Sciences of Ukraine was developed, created and perfected the standard stand RESVP-1, which allowed the creation of small air velocities. The considered method of aeromechanical measurements at low velocities of air flow provides the possibility of a very accurate setting of the speed of the crowding airflow affecting to the object under study, since in this case it is a linear velocity of movement the object being studied in motionless air. In the crowding flow affecting the object under study, no pulsations and vortices distorting the measurement results. Standard RESVP-1 is certified by standardization bodies Ukraine in the range of values of reproducible speeds from 0.000 to 1.200 m/s with the permissible value absolute error $\pm(0.001 + 0.003V)$, where V is the reproducible flow velocity, m/s.

1 Introduction

Tachometric converter of air flow velocity of modern anemometer [1, 10, 11] is an accurate measuring instrument, and its basic characteristics - range of measurements, error of static characteristic of transformation, dynamic properties, reliability and durability are practical completely determined by the parameters of the sensing element – vane - in conjunction with the rotation knots of its axis. Therefore, the stands, applied for aeromechanical studies parameters of the motion of the vane [12], should be working standards of the corresponding accuracy category and meet a number of technical requirements [13], the most important of which are the following:

- a) the ability to create an exemplary airflow in the range of speeds satisfying the purpose of the research;
- b) the limits of the permissible error corresponding to the class of accuracy of

*Corresponding author: dudnik1963@gmail.com

investigated samples of measuring instruments;

c) the fairly low value of the share of the accidental component of error in the characteristic of the total error;

d) the sufficient turbulence coefficient of air flow in the working area;

e) uniform cross-sectional profile of the air flow in the working area;

g) the dimensions of the workpiece that satisfy the admissible coefficient of loading by the sample under study;

i) protection against from carrying be the convection airflow of the environment of an additional error in the established value of air flow velocity;

j) independence of the set value of the air flow velocity from the voltage of the AC power supply and from influence of industrial noises.

To meet the needs of mining aerology [3] for all types of aeromechanical measurements in mine workings and ventilation ducts the mine anemometer should provide measurement of the air velocity from 0.1 to 20 m/s [6]. Provided in the present work the task protection of measurements of airflow velocities less than the threshold sensitivity of vane, requires the study of its dynamic characteristics at flow of at least 0.05 m/s. Top value of the range of speeds created by the working standards should be no less 45 m/s, which is necessary for the research of the strength of the vane at maximum loads [7, 8].

One of the most important tasks is the development and research of methods decrease in the limits of the permissible absolute error of tachometrical converter of the anemometer APR-2 to the values $\Delta'_{pr} = \pm(0.03 + 0.02V)$ in the interval of measurement from 0.15 to 1.20 m/s and $\Delta''_{pr} = \pm(0.1 + 0.05V)$ in the interval more 1.20 to 20.0 m/s, where V is the value of the measured velocity. The above expressions are the most fully take into account nature of the error of the tachometric converter.

In the general case, the limit of the permissible error of the working means of measurement is the sum of a non-eliminated systematic and accidental components of errors, calculated in accordance with [4]. The systematic component error of tachometric converter when used as an informative parameter of its frequency output signal only includes the limit of the permissible error of the working standard [4].

A characteristic feature of the tachometric converter APR-2 is the fact that a random component of it the error is slighting small in comparison with the non-eliminated systematic one. This has been repeatedly confirmed nearby representative studies, including at the State Special Russian air flow rate standards conducted by D.I. Mendeleyev Institute for Metrology (VNIIM), on the aerodynamic tube of Donetskyyi naukovo-virobnychiy tsentr standartyzatsii, metrolohii ta sertyfikatsii (Donetskyyi CSM) and Kyiv Institute of Civil Aviation Engineers.

In accordance with [4] if the condition is fulfilled

$$\frac{\theta}{S(\tilde{A})} \geq 8, \quad (1)$$

where θ – non-eliminated systematic error of the measurement result; $S(\tilde{A})$ – estimation of the mean square deviation of the measurement result, then the random component of the error is neglected and assume that the boundary of the measurement result is $\Delta = \theta$.

In this case, the error resulting from the neglect of its random component does not exceed 15 %.

2 Method

On the basis of the foregoing, it is legitimate to assume that when performing non-equality

(1) the limit of the permissible error of the working standard must be equal to the limit of the permissible error of the anemometer APR-2 as stated above characteristics of its error.

The above arguments are applicable to the estimation of errors results of measurements in scientific research. They allow it completely realize the abilities of the working standard with regard to properties object of research. However, according to the instruction of D.I. Mendeleyev VNIIM, the main institute of the Russian Federation on metrology means of measurement velocity of air flow, which is also adopted by Ukrainian Centre of Standartization and Metrology, with metrological attestation and all kinds of checks, the working standard should have a limit of permissible error is at least two times smaller than certified or verifiable means of measurement, i.e. so-called the coefficient of metrological reserve should be not less than two [5, 9]. In the some way, the limits of the permissible absolute error of the working standards, applied for research, as well as metrological attestation and all types of checks of the tachometric converter of the anemometer APR-2 should must to be no more, then:

- a) in the range of speeds from 0.15 to 1.20 m/s: $\pm(0.03 + 0.01V)$ m/s;
- b) in the range of speeds from 1.20 to 20 m/s: $\pm(0.05 + 0.025V)$ m/s.

The main reference means of storing and reproducing a unit of air flow velocity, as well as the creation of a wide range of values velocity of the air flow in the experimental aeromechanics is aerodynamic tube (AT).

The experience of working with high-quality measuring AT of different structures, including with the large AT of State special Russia's standard of air flow velocity, shows that at speeds less than 0.2 – 0.3 m/s blast becomes unstable, the level of pulsations increases due to the derangement of whirlwinds from the blades of a fan rotating with small turns, as well as the uniformity of the velocity field in the working part due to the small values of Reynolds number. In addition, to a large extent, on the results of measurements begin to influence a convective flows in the surrounded air, especially when working on the AT with an open working part, which makes them unreliable. These properties of AT do it the of little avail for speeds of stream less than 1.0 m/s and useless for speeds less than 0.5 m/s.

As a working standard for research in the area of the lowest air velocities starting from 0.03 – 0.05 m/s can be used the rotary stand, the simplified cinematic scheme of which is given in [2].

3 Results and discussions

The rotational stand realizes the principle circulation of motion, assumed in theoretical and experimental aeromechanics. Instead of influence on the investigated body by the air flow with specified speed, it is moved with this speed in motionless air. The law circulation of motion follows from the principle of relativity of Galileo, according to which, with steady progressive movement of the body in some environment (as in the air), the forces acting on the body depend only of relative velocity of body and environment.

When measured on a rotary test bench, the body under study moves along circles, being fixed to the horizontal bar of the bench, which rotates uniformly around the vertical axis with a given constant velocity. From here follows the main lack of the bench: the investigated body finds in the air, turned off by the bar, which changes the speed crowding on it flow both in magnitude and in direction, entering into the result of measurement random error. However, at very low speeds this disadvantage is practically not manifested. It is easy to see that at rotation radius of the researched body 1m and the set speed of the crowded stream 0.3 m/s the investigated body during a single measurement, equal to 10 s (rationed time for the primary transformer of the APR-2 anemometer is determined by the settled ability of signal for providing of exactness), passes less than half of length circle of

rotation, which is in our case 6.28 m.

The considered method of aeromechanical measurements at low air speeds flow has the following very significant advantages:

a) the possibility of a very accurate installation of the speed of the crowding air flow affecting on the investigated object, because it in this case is the linear velocity of movement of the investigated object in an immovable air;

b) the bench is a measure of speed, therefore a metrological certification of the stand eliminates the need for conducting of aeromechanical measurements with limited accuracy on small air flow speeds and, as a result, do not allow to realize accuracy of the method;

c) the bench together with the object under study can be placed in a closed screen and thus completely isolated from the influence of air streams, always present in the surrounding air and make essential accidental errors in the results of aeromechanical measurements on small speeds of the crowding stream;

d) in the crowding stream, affecting the investigated object, are absent pulsations and vortices, that distort the measurement results.

Before 2011, there were no standard devices for measuring low velocity of air flow in Ukraine. Used by Ukrmetrteststandard the Pitot-Prandtl model pressure tube has a precision class of 0.5, but the range of measuring begin at only 5 m/s. National Scientific Centre «Institute of Metrology» disposes by attested in Switzerland standard German thermoanemometer in the range of the speeds measured from 0.1 to 1.0 m/s by an error no more $(0.0003 + 0.002V)$ m/s, but can not create the stable current of air without pulsations and whirlwinds, distorting the results of measurings.

In Institute of Geotechnical Mechanics named by N. Poljakov of National Academy of Sciences of Ukraine was developed, created and perfected the standard bench RESVP-1, which allowed to create small air flow velocity (Fig. 1).



Fig. 1. Working standard of the speed of the air flow of the RESVP-1 in preparation for research of high-precision converter of an anemometer APR-2 of the third modification.

The principle action of the bench is to create air flow affecting on the primary converter, by way of displacement of the primary inverter in stationary air over circular orbit with a given linear velocity. Primary converter is attached to a horizontal rod mounted on a vertical axis rotating at a constant angular velocity. If radius of the displacement circle of the primary transformer, i.e. distance from the axis of bench to the vane axis equal R , mm, and the angular velocity of the rotation the axis of bench is n , r.p.s, then the linear velocity of the displacement of the primary converter, and hence the speed of the air flow, affecting on the primary moderator, will be

$$V_0 = 2 \cdot 10^{-3} \pi R N, \text{ m/s} \quad (2)$$

To ensure the constant angular velocity of the bench axis in time in the axis drive used a synchronous electric motor of alternating current, whose rotor rotates at a frequency strictly multiple frequency of the supply current. However, in accordance with applicable rules, the 50 Hz alternating current frequency of industrial electrical net should vary only within a range of ± 1 Hz, i.e. ± 2 %. This will cause corresponding deviations from a normal rotational speed of the bench axis. Therefore, a special system of accurate measurement of the axis rotational speed is used at the bench. On the axis vested a disk-shutter with 150 gear teeth, which are located along its edge through 2.4 angular degrees. When the shutter rotate, the teeth are modulated light stream of infrared optoelectronic converter, as a result of which its output signal contains 150 voltage pulses for one turn of the axis. After amplifying the pulses of voltage enter an electron-count frequency gauge whose readings are used to accurately determine and set the speed of created air stream according to the formula (2).

If during the measurement time t_{meas} the number of pulses at the output of optoelectronic converter was N , then the promptness of axis per second will be $n = N/150 \cdot t_{meas}$ and, respectively:

$$V_0 = \frac{2\pi R N \cdot 10^{-3}}{150 t_{meas}} = 4.19 \cdot 10^{-5} \frac{R N}{t_{meas}}. \quad (3)$$

But $\frac{N}{t_{meas}} = f_{osk}$, when f_{osk} – frequency of the output signal of optoelectronic converter,

Hz. Then $V_0 = 4.19 \cdot 10^{-5} R f_{osk}$.

The structure scheme of the bench is given on the Figure 2.

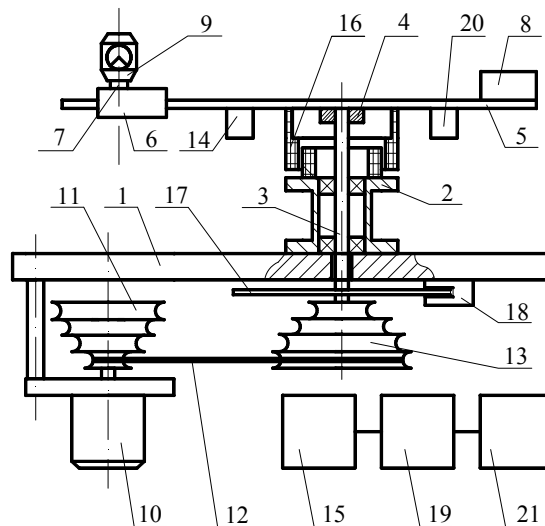

Fig. 2. Structural scheme of the bench with the regulated radius of rotation.

The basis of the stand design is a massive plate 1. In the center of its fixed a vertical tubular stand 2 in which installed axis 3 in two ball bearings. On the axis with the help of a special flange 4 fixed by rod 5 - steel measuring line with millimeter points. The slider 6 with nonius can move around the bar intended for immediate exact counting the radius of

travel of the verifiable primary converter 9, which is mounted in the holder 7. At the opposite end of bar is fixed the load 8, intended for balancing the mass of primary converter 9.

Axis 3 is rotated by a reversible synchronous electric motor 10 type SD-54 with built-in gearbox 1:191.4, on the output shaft of which is a four-stage pulley 11 with a working diameters 25, 37, 57, 80 mm. Pulley 11 is associated by passage 12 with a four-stage pulley 13, which is mounted on the lower end of the axis 3 and has working diameters 88, 78, 61 and 34 mm.

Such design of the drive allows you to change step by step the speed of rotation of the axis 3, rearranging the passage on the height of the pulleys.

Transmission of the output signal from the tested primary converter 9 fixed in the holder 7 on the slider 6, to the measuring instruments is carried out with the help of non-contact transmitting device including a transmitting node 14 and receiver node 15. Both nodes are interconnected through a rotating through pulse transformer 16 which contains two axially located multistage coils of inductance, one of which fixed on the axis 3, and the other - on rack 2. Such a method of transmission the information completely eliminates interferences and errors inherent in the contact systems.

On the lower end of the axis 3 is a metal toothed disk-shutter 17 whose teeth modulate the light flux of optoelectronic converter 18. Output signal of the converter is amplified and converted into a sequence of rectangular impulses with node 19 and is fed to the input electron-count frequency gauge.

Power supply to the electric circuit is carried out from two sources - standalone 20 (4 galvanic elements of type A316 (or AA, LR6)) and network 21.

A bench was made in the form of a stationary floor structure. Its base is a metal curb, closed decorative panels. On top, a plate 1 is attached to the curb which is mounted all the nodes of the bench.

Resulted structural to the chart appeared is not deprived the row of the substantial failings. At the beginning of motion of massive steel barbell 5 and at some speeds of its rotation there were auto vibrancy which were included in resonance with the torsion billow of vertical axis 3, passing a twisting moment from a drive. Large inconvenience was represented by the system of task of exact rate of movement of transformer by belt-drive 12 and establishments on the vernier of the required radius of rotation. Diminishment of radius and ambiguousness of trajectory of motion of the explored transformer, also is the lack of the offered method of measurings. For the removal of failings the improved kinematics system was developed. In place of the heavy thick-walled barbell with the slide-block 6 it was suggested to apply the easy thin-walled tube with the thickness of wall only 0.3 mm. Thus a transformer was fixed on the butt end of barbell and was revolved always on permanent, maximally outermost distance axis. High inflexibility of construction was arrived at by three vant stretching. For the smoothness of adjusting it was suggested to develop the special system of automatic control, which allowed fluently to set necessary speed of rotation.

Thus the value of the set speed hatches on the electronic board of the frequency meter, directly inducted actual speed of moving of the explored transformer. For the exception of influencing of concomitant stream arising up at the rotation of barbell, the system of adjusting is equipped by the mode of revers.

The improved kinematics chart with the fixed radius of rotation is represented on the Figure 3.

Drive engine of direct current with tachometric generator 1 by membrane muffs 2 and 4 and the long intermediate billow 3 is connected with the worm reducing gear formed by a worm 5 and the worm-wheel 6.

The use of membrane couplings 2, 4, connected by shaft 3, made it possible to

compensate for the misalignment and misalignment of the motor shaft and the worm that occur during installation of the system, as a result of which fluctuations occur periodically, the load on its output shaft 3 was excluded. The ever higher inflexibility of the membrane coupling in the tangential direction eliminated its backlash and allowed the system to stabilize during transients when dead movement is impossible.

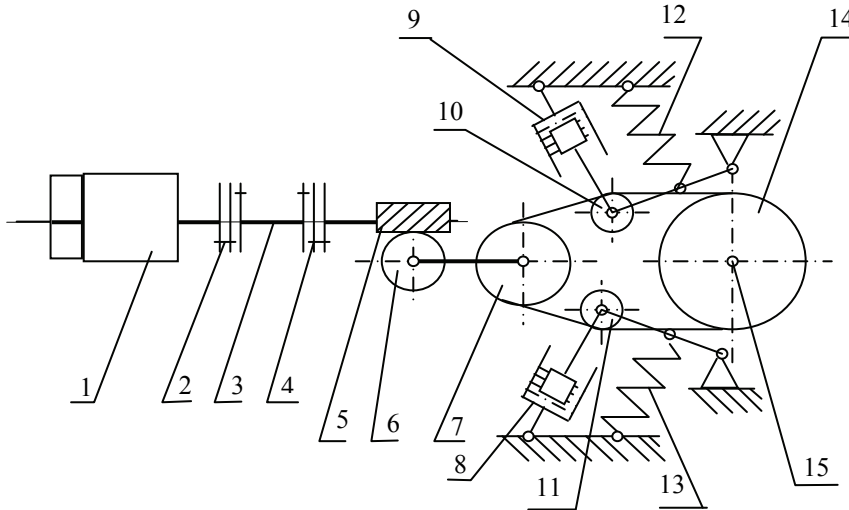

Fig. 3. Improved kinematics chart of stand with the fixed radius of rotation.

On the billow of worm-wheel 6 a pulley 7 is hardly planted, which by the flexible strap 16 passes the rotation to the pulley 14, set on the output billow of the bench 15. A strap is executed from the tissue stripe weaved from synthetic threads. The system uses pull rollers 10, 11, the tension of which is carried by the spiral springs 12, 13. Parallel to the springs dampers are connected 8, 9, setting of which is the decline of mechanical good quality of the system. The size of pull of springs and degree of dampering adjusted experimentally in the process of assembling and tuning of drive. Thus the degree of dampering was regulated by application of different brands of silicon-organic polymetilsiloksan liquid and oilsbutters of a different viscosity. Node of billow 15, bearings and system reading of signal are used from previous construction and remained without the changes.

Improved by a kinematics scheme at the tests showed the high smoothness of motion, character of transitional processes near to aperiodical vibrations, practically complete absence of vermin autovibrations of bar, caused by turning torsion vibrations of its billow in the range of speeds of crowded stream from 0.05 to 1.2 m/s. Thus the radius of rotation object of aeromechanical researches - primary convertors APR-2 made 0.8 m. In quality a drive engine the collector engine of direct current of the type PIVT 6-25/3A of a Bulgarian production was used. Angular speed of his output billow in the process of researches was regulated by the change of feeding voltage, and its size was measured by obtyurat, fastened on axes, and optoelectronic pair. Its output frequency-impulsive tension was controlled with high exactness by the electronic-account frequency meter of the type 43-57.

Engine of PIVT 6-25/3A is specially developed for work in the systems of automatic control and combined with tachometrical generator, the rotor of which is directly fastened on his billow. It does very comfortable the use of him in the developed system of watching drive, as output tension of tachometrical generator with high exactness is proportional to angular speed of billow of engine and makes 3 V at angular speed of billow 1000 r.p.m. At minimum angular speed of billow of engine, equal 66.7 r.p.m., that corresponds to speed 0.05 m/s of crowding stream, output tension of tachometrical generator makes about a

0.2 V. This is enough large tension for the use of him in quality the signal of feed-back in the system of automatic control of angular speed of engine. An engine develops a twisting moment 0.1 Nm at 3000 r.p.m. and provides alteration of his angular speed in very wide limits – from units of r.p.m. to nominal. Nominal tension of feed of engine makes 30 V, that is also very comfortable at the use of him in the system of adjusting, executed on semiconductor elements.

The model of mechanical prototyping of bench made in accordance with the resulted kinematics chart of Figure 3 at the tests showed the high smoothness of motion, practically complete absence of vermin autovibrations of barbell, caused by turning torsion vibrations of its billow, and also character of transitional processes near to aperiodical in all working range of speeds. It is possible to conclude that the considered kinematics chart because of its simplicity, high repetition and satisfactory of dynamic descriptions fully can be recommended for creation of standard rotary bench of small speeds of current of air.

Basic technical descriptions and sizes of mechanical part of the working standard RESVP-1, built in accordance with the considered kinematics chart, presented in Table 1.

Table 1. Technical descriptions and sizes of mechanical part of the working standard RESVP-1.

Technical descriptions	Sizes
Range of the reproduced standard values of speeds of crowding stream, m/s	0.05-1.20
Working radius of rotation object of researches, m	0.789
Total gear-ratio of the system from the output billow of engine of drive to the billow of bar	110.22
Gear-ratio of worm reducing gear	66
Gear-ratio of strap transmission	1.67
Working diameter of small pulley, mm	100
Working diameter of large pulley, mm	167
Angular speed of barbell at speed of crowding stream 0.05 m/s, r.p.m.	0.605
Angular speed of barbell at speed of crowding stream 1.20 m/s, r.p.m.	14.5
Number turns of drive engine at speed of crowding stream 0.05 m/s, r.p.m.	66.7
Number turns of drive engine at speed of crowding stream 1.20 m/s, r.p.m.	1598.2

Figures 1 and 4 show a protective aerodynamic screen.

This improvement has become a necessary part of the measurement procedure, i.e. at air velocity close to 0.15 m/s is near measurable object without significant additional interference is impossible. With the help of the anemometer APR-2 it is easy to verify that the palm of hand creates an ascending airflow at a speed of 0.3 m/s, and any short-term movements of the personnel create perturbing flows, which can be observed in room within a few minutes after termination all kinds of movements.

Fractional values of working radius of rotation object of researches and total gear-ratio from the billow of engine to the billow of bar are chosen from the condition of comfort of exact control of angular speed of rotation billow of engine by an optoelectrical converter with obturator, having 45 openings on a circumference. The resulted values parameters of the system are used for the calculation of automatic watching drive of output billow of working standard.

Screen 1 of Figure 4 is made of foam plastic, which as known to have a good thermal insulation properties. The screen at work has the ability to climb and tightly fit on the desk 2, also covered foam plastic. Via the four pneumatic stacks 5 with the piston 6, the screen activated by an air compressor 7.

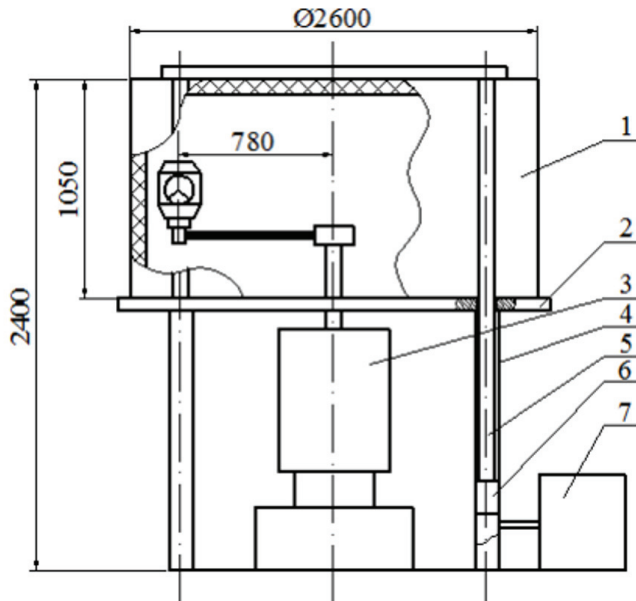

Fig. 4. Protective aerodynamic screen: 1 – screen; 2 – the bottom of the screen; 3 – rotational bench; 4 – stationary; 5 – pole mobile; 6 – piston; 7 – compressor.

One of basic lacks of rotary bench is twirling of stream under action of the revolved bar and explored converter set on her. For diminishment of this effect a protective screen is executed not as a cylinder, and as a 16 cut prism. If necessary into a screen it is possible additionally to set ribs perpendicular to the verges. On this account high speed of bench does not exceed 1.2 m/s. The most high-quality measuring turn out at the small values of speed and near to zeroing.

Conclusions

Thus, as a result of the conducting research, a new strategy reproducing of small air velocity, which is can be used to improve of aerodynamic measurements by the anemometer APR-2, worked out, and put into practice its technical realization. Standard RESVP-1 is certified by the standardization bodies of Ukraine in the range of reproducible speeds from 0.000 to 1.200 m/s with the value of the permissible absolute error $\pm(0.001 + 0.003V)$, where V - reproducible flow of stream.

References

1. TC U 10.1-1.1-05411357-001-2001. Anemometer a portable mine APR-2. (2001). IGTM NAS of Ukraine, Dnipropetrovsk, UA
2. The State Standard (GOST) 6376-74. Hand anemometer accounting device. Specifications. (1974). Moskva
3. Ukraine Ministry of Coal Industry. State Committee of Ukraine by Industrial Safety. Protection of Labour and Mine Inspectorate. (2010). *NPAOP 10.0-1.01-10 Pravyła bezpeky u vugilnykh shakhtakh. Normativny document Minugleproma Ukrainy. Standart [NLASL 10.0-1.01-10 Rules of Safety in Coal Mines. Norm document of Ministry of Coal Industry of Ukraine. Standard]*. Kyiv
4. The State Standard (GOST) 8.297-76. State system for ensuring the informity of measurements. Direct measurements with multiple observations. Methods of processing

- the results of observations. Basic principles. (1976). Moskva
5. Law of Ukraine. (2014). Pro metrologiyu ta metrologichnu diyalnist. *Vidomosti Verkhovnoi Rady (VVR)*, 30, 1008
 6. Rumyantseva V.A. (2001). Upgrading of measurement equipment for aerodynamic parameters of ventilation systems. Ph.D. Thesis, Moskva
 7. Ushakov, K.Z., Burchakov, A.S., Puchkov, L.A., Medvedev, I.I. (1987). *Aerologiya gornykh predpriyatiy*. Moskva: Nedra
 8. P. Moonen, B. Blocken, S. Roels, J. Carmeliet. (2006). *Journal of Wind Engineering and Industrial Aerodynamics*, 94, 699-723
 9. Biryukov, S.V., Cheredov, A.I. (2000). *Metrologiya: Teksty lektsiy*. Omsk: OmGTU
 10. Vereshchagin, G.L., Spirin, S.V., Yegorov, V.N., Dmitriyenko, A.N. (2007). Vozdushno-depressionnyye semki na novom tekhnichaskom urovne. *Safety of labour in industry*, 11, 50-51
 11. Krukovsky, A.P., Belikov, Yu.D., Dudnik, M.N. (2013). Anemometr APR-2 – sovremennoye sredstvo kontrolya rudnichnoy ventilyatsii. *Coal of Ukraine*, 7, 26-29
 12. Veretennik, V.N. (2011). O matematicheskoy modeli nestatsionarnogo dvizheniya krylchatki i sposobe izmereniy malykh skorostey vozdushnogo potoka, *Geo-Technical Mechanics*, 49, 133
 13. Gorlin S.M. (1970). *Ekspperimentalnaya aeromekhanika*. Moskva: Vysshaya shkola