

Problems of energy efficiency of heat supply systems

Tatyana Rafalskaya^{1*}

¹Novosibirsk State University of Architecture and Civil Engineering (Sibstrin), Leningradskaya str., 113, Novosibirsk, Russia

Abstract. The main task of energy-efficient heat supply is to ensure full compliance between the produced and consumed thermal power, subject to a minimum of reduced costs. To achieve this goal, various methods of central and local regulation are applied. Analysis of the thermal schemes of some cities in Russia showed that most of the heat sources of centralized heat supply systems are not able to support the design high-temperature graphs with central regulation. Therefore, the area of centralized qualitative method of regulation of heat load has decreased substantially. A perspective direction for the further development of heat supply systems is to appeal to the experience of foreign countries, i.e. the use of qualitative-quantitative and quantitative methods of central regulation and low-temperature heat supply. There is also an acute problem of the complete use of heat by consumers, since overstating of the temperature of the return water substantially reduces the efficiency of heat sources. A new formula has been obtained which makes it possible to predict the temperature of the return network water in variable operating modes of heating points. The resulting formula can be used to set up programmable regulators and will allow correcting irrational modes of operation of heat supply systems.

1 Introduction

One of the main problems of heat supply systems is the problem of efficient use of thermal power. Heat power is determined by the flow rate and temperature difference of the coolant

$$Q = Gc\rho(t_{p1} - t_{p2}) = W(t_{p1} - t_{p2}), \quad (1)$$

where Q is the thermal power, W ; G is the coolant flow rate, m^3/s ; c and ρ are specific heat capacity, $J/(kg \cdot ^\circ C)$ and density, kg/m^3 of heat carrier; t_{p1} and t_{p2} are initial and final temperature of the coolant, $^\circ C$; W is the equivalent of the coolant flow rate, W/K .

In order to increase the efficiency of using heat energy at the heat source, temperature control graphs are applied. The main ways of central regulation are:

- qualitative regulation when the water temperature in the supply t_{p1} and return t_{p2} mains of the heating system change depending on the outdoor temperature t_{out} with a constant flow of network water G_p ;
- quantitative regulation when the temperature of the water in the supply pipeline of the heating network t_{p1} is constant during the entire heating period and the flow rate of the supply water G_p varies depending on the outdoor temperature;
- qualitative and quantitative regulation when the temperature and flow rate of the supply water are changing depending on the outside temperature.

2 Literature review

In Russian heat supply systems, historically, a qualitative method of central regulation was predominantly used. In

the period up to 1945-1950 the temperature graph of $130/70^\circ C$ prevailed in the Russian heat supply systems and since 1951 the central qualitative temperature graph of $150/70^\circ C$ of central regulation was adopted in the former USSR [1] which is currently the most common for centralized heat supply systems in Russian federation. The equipment for heating networks, heat exchangers of heating systems and hot water supply, diameters of pipelines of heat supply networks are selected for the parameters of this graph. Increasing the estimated water temperature in the network allows reducing network water consumption and pipeline diameters which reduces investment in heating networks and reduces energy consumption for pumping coolant, which is cost-effective for heat supply from regional boilers.

In case of heat supply from the CHP, an increase in the design temperature of the water necessitates an increase in pressure in the heating sections of turbines and in some cases leads to the need to use steam from industrial sections with a corresponding decrease in power generation on heat consumption.

In the 60-70s of the 20th century [1-3] the projects of high-temperature heat supply were considered (but not implemented), for example, a temperature graph of $200/70^\circ C$ was planned for the heat supply system of Irkutsk; in projects of CHP-4 in Minsk, CHP-3 in Karaganda, CHP-26 in Moscow planned temperature schedules of regulation with the estimated temperature in the supply line 180 and $190^\circ C$ in the transit sections of heating networks. In foreign practice, temperature graphs were also used with a design temperature in the supply pipeline of 160 , 170 , 180 and even $210^\circ C$, mainly in systems that receive heat from district boilers or in the

rafalskaya.ta@yandex.ru

scheme of connecting the heating system through a heat exchanger [1].

However, in recent decades, heat supply sources in the Russian Federation began to work on a temperature schedule with a cutoff, i.e. with underheating of the network water in the supply line to the design values caused by the rising cost of fuel, lack of funds for upgrading the equipment of heat supply systems, stopping peak heat sources [4-6].

For example, the fig. 1 shows a central regulation graph in Novosibirsk.

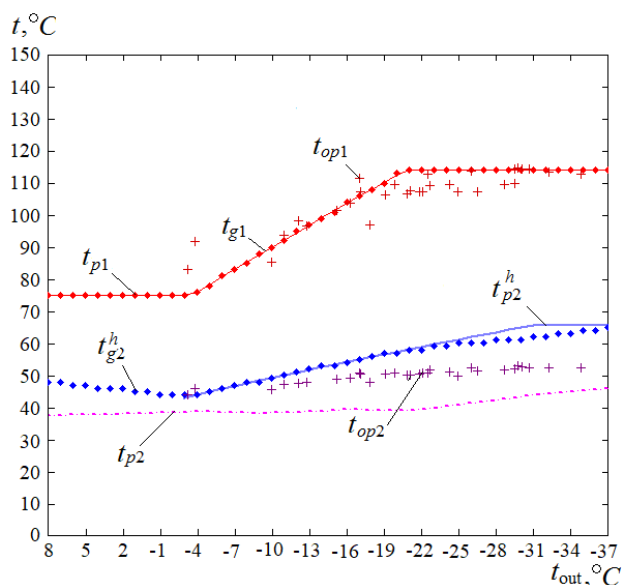

Fig. 1. Temperature graph of Novosibirsk CHP. t_{p1} is the calculated temperature in the heat supply network; t_{g1} is the temperature of water in the supply line of the heating network according to the graph of the CHP; t_{op1} is operating average daily temperature in the heating system supply line; t_{p2}^h is calculated temperature in the return line of the heating system; t_{g2}^h –temperature in the return line on the graph of CHP; t_{p2} is the calculated temperature in the return line of the heating network; t_{op2} is operating average daily temperature in the return line of the heating network.

The main advantages of low-temperature heating are: reducing heat losses in heating networks [6], increasing the amount of electricity supplied to existing CHP plants without peak boilers, in which peak loads are provided by steam of unregulated sections [7], reduction of energy costs due with overestimated norms of the average value of the air exchange rate of residential apartment buildings in Russia compared with the norms of a number of EU countries and the USA [4]. The use of the upper cut of the temperature graph, as well as raising the lower cut to ensure the temperature of hot water consumption at least 60°C led to a sharp reduction in the area of central qualitative regulation.

3 Analysis of the temperature graphs. The main directions of development

Analysis of the thermal scheme of a number of cities in Russian Federation showed that the percent of

qualitative regulation according to the temperature graph with a cut-off is no more than 30-63% (Table I). In the works [4, 7] it is proposed for all newly designed CHP plants to choose the classical temperature schedule of 115/70°C without cutting under qualitative regulation, after specifying reduced heating loads. For existing stations, it is recommended to conduct research to determine the optimal level of reduction in the temperature schedule of heating networks [7].

If we consider the regulation graphs with the estimated water temperature in the supply line equal to the upper cutoff temperature, then we can see that the area of qualitative regulation in this case will be larger and will amount to 49-76% (Table 1).

At the same time, the transition to low-temperature heat supply, in addition to increasing the estimated flow rates of network water, will also shift the fracture point of the temperature graph to the area of lower outdoor temperatures. In the high-temperature graph with the upper cut, the area of qualitative regulation corresponds to the average-winter outdoor temperatures. Therefore, at low temperatures of the outdoor air, the heat capacity of the hot water supply is largely provided by the heat of the return supply water, so it is possible to compensate for the decrease in the temperature of the water in the heating network by increasing the flow of supply water without exceeding the calculated value. In the low-temperature graph, the qualitative regulation area will correspond to the range of lower outdoor temperatures. Given that the duration of standing low outdoor temperatures for most cities is much less than high, it is possible to determine the length of time for quality regulation. As the data in Table 2 show, for most cities this duration did not increase but decreased and amounted to 22-61%.

Thus, there has been a tendency of transition to other ways of central regulation: qualitative-quantitative and quantitative. So in Denmark (Copenhagen) more applied quantitative regulation. The temperature graph of the heating networks is 120/50°C with a working pressure of the coolant 2.5 MPa. Low-temperature heat supply from district boilers using heat pumps is also used; during the heating season, the water temperature in the supply line is constant at 80°C, and non-heating at 65°C [8]. In Germany, in some cities, district heating boilers are used, which operate on temperature graphs with a temperature in the supply pipe of heating networks 130-100°C depending on the outdoor temperature. Apply qualitative and quantitative regulation, carried out, as a rule, steps. For example, the temperature graph in Dresden consists of seven steps [9]. In China, district heating systems and methods for central regulation of heat loads are very diverse. For example, low-temperature graphs of quality regulation are applied 65/55°C, in which the temperatures of the water in the flow and return lines of the heating network changes linearly [10]. There are also systems with a sufficiently high calculated coolant temperature of 120–110°C [11] with qualitative and qualitative–quantitative regulation and stepwise regulation.

Table 1. Duration of the central quality regulation according to the temperature graph.

No.	City	Calculated temperature graph, °C	Upper cut, °C	Design outdoor temperature, °C	Outdoor temperature range with qualitative regulation, °C		Percentage of quality regulation on the temperature graph, %	
					with upper-cut	without upper-cut	with upper-cut	without upper-cut
1	Vologda	130/70	115	-32	-3÷-24	-6÷-32	52.5	65.0
2	Yekaterinburg	150/70	120	-32	0÷-20	-5÷-32	50.0	67.5
3	Essentuki	115/70	95	-20	0÷-11	-6÷-20	39.3	50.0
4	Zheleznogorsk	130/70	115	-24	0÷-18	-2÷-24	56.3	68.8
5	Ivanovo	150/70	120	-30	1÷-18	-4÷-30	50.0	68.4
6	Kazan	130/65	115	-31	-3÷-24	-6÷-31	53.8	64.1
7	Krasnoyarsk	150/70	130	-37	-1÷-28	-5÷-37	60.0	71.1
8	Kurgan	150/70	100	-36	-1÷-14	-13÷-36	29.5	52.3
9	Magnitogorsk	150/70	110	-34	0÷-17	-9÷-34	40.5	59.5
10	Moscow	150/70	130	-25	3÷-18	0÷-25	63.6	75.8
11	Nizhny Novgorod	150/70	110	-31	1÷-15	-7÷-31	35.9	61.5
12	Novosibirsk	150/70	114	-37	-4÷-21	-12÷-37	37.8	55.6
13	Omsk	150/70	116	-37	-1÷-22	-8÷-37	46.7	64.4
14	Orel	110/70	95	-25	-4÷-17	-9÷-25	39.4	48.5
15	Perm	150/70	135	-35	-1÷-28	-3÷-35	62.8	74.4
16	Rostov-on-Don	150/70	115	-19	5÷-8	0÷-19	48.1	70.4
17	Samara	130/70	115	-30	-2÷-23	-5÷-30	55.3	65.8
18	Smolensk	150/70	115	-25	3÷-13	-3÷-25	48.5	66.7
19	Surgut	150/70	112	-43	-4÷-24	-13÷-43	39.2	58.8
20	Tomsk	150/70	125	-39	-2÷-27	-7÷-39	53.2	68.1
21	Tyumen	150/70	121	-35	-1÷-22	-6÷-35	48.8	67.4
22	Ulan-Ude	136/70	110	-35	-3÷-22	-9÷-35	44.2	60.5
23	Ufa	150/70	130	-33	0÷-25	-3÷-33	61.0	73.2

Table 2. Duration of the central quality regulation for the duration of outdoor temperatures.

No.	City	Duration of the heating period		Duration of quality regulation, h, for graphs		Percentage of qualitative regulation by the duration of outdoor temperatures, %, for graphs	
		days	h	with upper-cut	without upper-cut	with upper-cut	without upper-cut
1	Vologda	228	5472	3832	2765	70.0	50.5
2	Yekaterinburg	221	5304	3465	2957	65.3	55.8
3	Essentuki	178	4272	1905	635	44.6	14.9
4	Zheleznogorsk	198	4752	2798	2484	58.9	52.3
5	Ivanovo	219	5256	3040	2246	57.8	42.7
6	Kazan	208	4992	2767	2292	55.4	45.9
7	Krasnoyarsk	250	6000	3483	3055	58.1	50.9
8	Kurgan	212	5088	2174	1844	42.7	36.2
9	Magnitogorsk	218	5232	3139	2683	60.0	51.3
10	Moscow	223	5352	3465	2927	64.7	54.7
11	Nizhny Novgorod	215	5160	3738	1938	72.4	37.5
12	Novosibirsk	221	5304	2631	1897	49.6	35.8
13	Omsk	216	5184	3068	2787	59.2	53.8
14	Orel	199	4776	1713	1039	35.9	21.8
15	Perm	225	5400	3510	3269	65.0	60.5
16	Rostov-on-Don	166	3984	2751	2298	69.1	57.7
17	Samara	203	4872	2711	2330	55.6	47.8
18	Smolensk	209	5016	3256	2226	64.9	44.4
19	Surgut	274	6576	2792	2359	42.5	35.9
20	Tomsk	233	5592	3449	2971	61.7	53.1
21	Tyumen	223	5352	3158	2793	59.0	52.2
22	Ulan-Ude	230	5520	2518	3110	45.6	56.3
23	Ufa	209	5016	3473	3050	69.2	60.8

4 Comparative analysis of heating systems in different countries

Finland and Norway. The results of the analysis are presented in Table 3.

It is advisable to compare heat supply systems with similar climatic parameters: Russia, Denmark, Sweden,

Table 3. Comparative analysis of heat supply systems.

Country	Russia	Denmark	Finland	Sweden	Norway
Comparison criterion	Temperature graph, °C				
	150/70	120/50	120/65	120/65	120/70
	Fuel used to generate heat				
	Coal, natural gas, liquid fuel	Coal, natural gas, liquid fuel	Coal, natural gas, peat and oil	Natural gas, liquid fuel	Waste heat from waste treatment plants
	Scheme of connection to the heat network				
	without heat exchanger, with heat exchanger	with heat exchanger	with heat exchanger	with heat exchanger	with heat exchanger
	Cost of thermal energy, rub./GCal				
1200-1400	1700	2000-2500	2500-3000	3000-3400	

Centralized heat supply still occupies a significant amount of power system, both in Russia and abroad. At the same time, foreign heating systems mainly use simpler methods of both central and local regulation, with the exception of China, where Russian methods of regulating heat loads are applied. The use of decentralized heat supply in foreign countries, i.e. separate generation of heat and electricity increases the final cost of heat energy. Temperature graphs in foreign heat supply systems are lower than in the Russian systems, and this is due, in many respects, to the insignificant length of heating networks and a milder climate which makes it possible to use pipes of relatively small diameter for low temperature heat supply.

directly affects the performance of the heating system, resulting in excessive energy consumption during transportation of the coolant and increased fuel consumption for the production of thermal energy due to increased volumes of network water and a decrease in the efficiency of heat sources. For example, the fig. 3 shows the operating modes of the CHP in Novosibirsk on January 9-16, 2018, where it can be seen that under certain operating modes, the temperature of the water returned to the heating network exceeds even the temperature of the water after the heating system.

This is due to the irrational use of heat energy by consumers. In heat points of heat supply systems, groups of heat exchangers are used with the redistribution of heat flows in a variable mode of operation, i.e. with a connected supply of heat (eg, see fig. 3). This scheme allows reducing the flow of network water and using the heat of the return line. However, the regulatory system is designed to maintain only “estimated” flow rates and temperatures which does not allow for the effective use of the advantages of this scheme.

5 Improving the efficiency of heating points of heat supply systems

The main indicator of the effective use of thermal power is the temperature of the return water. The increased temperature of the return network water

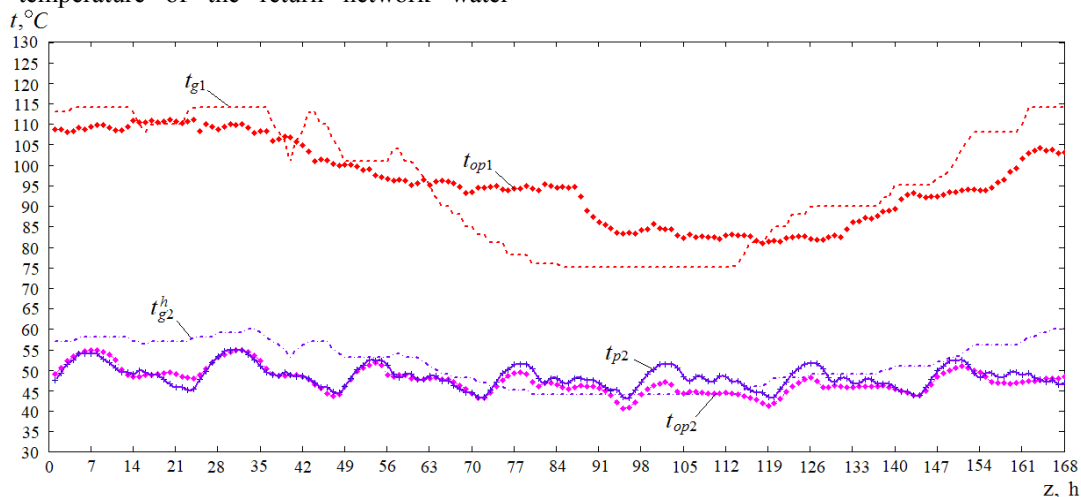

Fig. 2. Network water temperatures January 9-16, 2018. Designations see fig. 1.

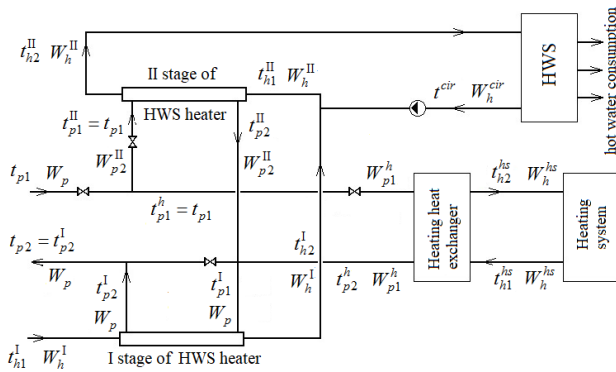

Fig. 3. The scheme of heating point with a tied supply of heat. Network water temperatures see notation for fig. 1. Temperatures of heated water: t_{h1}^I - in the cold water supply system at the inlet to the I stage of HWS heater; t_{h2}^I - after the I stage of HWS heater; t_{h1}^{II} - at the inlet to the II stage of HWS heater; t_{h2}^I - after the II stage of HWS heater; t^{cir} - in the circulating line of HWS. Equivalent of network water flow rates: W_p - in the heat supply network; W_h^{II} - at II stage of the HWS heater; W_p^{II} - from the heating network to the heating system; W_h^{hs} - in the supply line of the heating system. Equivalent of heated water flow rates: W_h^I - in cold water supply; W_h^{cir} - in the circulation line of HWS; W_h^{II} - in HWS.

6 Predict of return network water temperature

The existing theories of calculating variable modes of heat exchangers are based on the use of constant dimensionless parameters [12], which reduce the number of unknowns. The number of transfer units (heat exchanger parameter Φ_0), is determined by [12]

$$NTU = \Phi_0 = (kF)_c / (W_{pc} W_{hc})^{0.5}, \quad (2)$$

where $(kF)_c$ the product of the heat transfer coefficient in the installation conditions on the area of the heat exchanger; W_{pc} , W_{hc} are the installation equivalents of the flow rates of the primary and secondary heat carriers.

The formula (2) does not include the temperature of coolants, which reduces the number of unknowns. At the same time, NTU can be affected by all quantities that determine the change in heat transfer coefficient.

The analysis of various variable modes of operation of heat exchangers, performed in [13], made it possible to obtain a formula describing the change in the heat exchanger parameter in variable mode [14]:

$$NTU(t_{out}) = \frac{Q_h}{\Delta t_c (W_p W_h)^{0.5}} \times \left[\left(\frac{W_h}{W_p} - 1 \right) \frac{NTU}{J} \pm \frac{Q_{hc}}{Q_h} \left(\frac{W_p W_h}{W_{pc} W_{hc}} \right)^{0.5} \right], \quad (3)$$

where Q_{hc} , Δt_c are the calculated values (in installation conditions) of the heat capacity of the heat exchanger, the equivalents of the flow rates of the heating and heated coolants and the average log temperature

difference in the heat exchanger; J is the coefficient depending on the mode of operation of the heat exchanger: for the I stage of the HWS heater $J = 8.996$; for II stage of the HWS heater $J = 19.923$; the “-” sign in the (3) is applied at a constant temperature of the heated coolant at the inlet to the heat exchanger; “+” sign in other cases.

The temperature of the return water can be determined from the balance equation of the heat exchanger

$$t_{p2}(t_{out}) = Q_h / (\varepsilon W_h) + t_{h1}, \quad (4)$$

where ε is heat exchanger efficiency:

$$\varepsilon(t_{out}) = \frac{1}{a \frac{W_h(t_{out})}{W_p(t_{out})} + b + \frac{1}{NTU(t_{out})} \left(\frac{W_h(t_{out})}{W_p(t_{out})} \right)^{0.5}}, \quad (5)$$

where $a = 0.35$ and $b = 0.65$ are constant coefficients taken according to [7], $NTU(t_{out})$ by the (3).

Using (3) - (5), the temperature of the return water was calculated (see Fig. 2) and correlation-regression analysis was performed. Correlation coefficient

$$r = \frac{n \sum x_i y_i - \sum x_i \sum y_i}{\sqrt{(n \sum x_i^2 - (\sum x_i)^2)(n \sum y_i^2 - (\sum y_i)^2)}}, \quad (6)$$

where n is the amount of data; x_i are values of operating data; y_i are values of calculated data.

The correlation coefficient is $r = 0.802$, which indicates a sufficient accuracy of the obtained relations.

7 Conclusions

An analysis of the stages of the development of heating systems in Russia showed that the basis of the feasibility study for increasing the temperature graph in heat supply system. However, in modern conditions, heat sources are not able to maintain high-temperature central control graph, which led to the appearance of temperature graphs with an upper cut and a gradual abandonment of the high-quality control method. The experience of foreign heat supply systems shows that good economic indicators can be achieved through low-temperature heat supply, improved designs of all components of the heat supply system, combined generation of electrical and thermal energy and full automation of consumer heating points. The task of the automation system is to fully utilize the heat power of the heat supply system in variable operating modes, for which it is necessary to use programmable controllers.

New formulas have been obtained that allow us to describe the effect of coolant flow rates on the heat exchanger parameter in variable operating modes. The resulting formulas allow us to predict the temperature of the return network water and can be used to configure programmable regulators, which will allow correcting inefficient modes of operation of the heating system.

References

1. M.M. Peak, I.A. Smirnov and R.L. Ermakov, *The choice of temperature schedule for regulating heat supply in centralized heat supply systems*, J. Water supply and sanitary eng., 11, 16-21 (1974) (in Russian).
2. V.I. Sharapov and P.V. Rotov, *Regulation of the load of heat supply systems*, Moscow: Heat supply news, 174 (2007) (in Russian).
3. A.V. Spirin and E.M. Malaya, *Reducing the reliability of district heating systems with non-compliance with the temperature schedule*, J. Bulletin of the Saratov State Technical University, 2, 1(45), 199-203 (2010) (in Russian).
4. V.A. Petrushchenkov, *Justification of the reduced temperature schedule of regulation of centralized heating systems*, J. News of heat supply, 8, 30-37 (2015) (in Russian).
5. T.A. Rafalskaya, *Investigation of Failures in Operation of Heat Networks of Large Heat Supply Systems*, Thermal Engineering, 64, 4, 313-317 (2017).
6. O.F. Gavey and V.I. Panferov, *The optimum temperature of the heat carrier in district heating systems*, Plumbing, heating, air conditioning, 1(145), 68-71, (2014) (in Russian).
7. A.S. Belyaev, E.K.Gorbatova and N.V. Mukhin, *Reducing the temperature graph of thermal networks of CHP*, J. Energy Saving and Water Treatment, 1(87), 24-29 (2014) (in Russian).
8. H.Pieper, Ommen T.S., W.B. Markussen and B. Elmegaard, *Optimal usage of low temperature sources to supply district heating by heat pumps*, In Proceedings of ECOS (2017).
9. A.V. Sednin and P.Yu. Marchenko, *To the choice of the method of regulation of heat supply from the CHP*, J. News of higher ed. Inst. and energy assoc. of the CIS. Energy, 1, 48-54 (2008) (in Russian).
10. J. Yiwen, Li Yi, L. Zhaohui and L. Rui, *Real Operation Pattern of District Heating System and Its Heating Effects*, J. Proc. Eng., 1741-1748 (2015).
11. S. Xiaofang, W. Peng, R. Panhong and Z. Hua, *The Influence of Central Regulation Methods upon Annual Heat Loss in Heating Network*, MATEC Web of Conferences, 54, 06004 (2016).
12. E.Ya. Sokolov, *Heating and heat networks*, Moscow: Publishing house MEI, 472 (2001) (in Russian).
13. T.A. Rafalskaya and V.Ya. Rudyak, *On the applicability of the ratios with constant parameters for calculation of variable modes of heat exchangers*, J. News of Higher Ed. Inst. Constr., 8, 91-107 (2018) (in Russian).
14. T.A. Rafalskaya and V.Ya. Rudyak, *Influence of coolant flow rates on the heat exchanger parameter at variable operation modes*, J. Vestnik MGSU, 14, 5, 621-633 (2019) (in Russian).