

Computer modeling of the wind power unit constructions with power over 2 MW

*U M Strelkov*¹, *O V Radaykin*², *L S Sabitov*^{1,3,*} and *A V Akhmerov*³

¹Kazan Federal University, 18 Kremlyovskaya street, Kazan, 420008, Russian Federation

²Kazan State University for Architecture and Engineering, 1 Zelenaya street, Kazan, 420043, Russian Federation

³Kazan State Power Engineering University, 51 Krasnoselskaya street, Kazan, 420066, Russian Federation

Abstract. The aim of this work is to evaluate the efficiency of the system “steel tower - reinforced concrete foundation – foundation ground” of a wind power unit with power more than 2 MW using computer simulation in ANSYS. For this purpose, an example of a wind power unit is taken from the previous work, but in this case the lower part of the tower up to height of 20 m was filled with B60 concrete. The second distinctive feature of the presented wind power unit is the use of a collapsible foundation, which was manufactured according to our patent. The simulation takes into account the spatial reaction of elements of the structural system and the physical nonlinearity of the materials from which they are made. In this case, for steel the von Mises theory of strength was used, for concrete the Williams-Varnack theory was used, and for ground base the Drucker-Prager theory was used. Comparison of the obtained results with data of previous work showed that the breaking load of tower has increased by 57% due to filling the lower part of the tower by concrete, which indicates the efficiency of the proposed solutions.

1 Introduction

Wind generators (wind power units, wind turbines) are used to convert kinetic energy of wind flow to mechanical rotational energy with its subsequent conversion to electrical energy. They consist of a wind turbine, which is unwound by a rotor with blades; an electric generator; a tower or a mast, the basement of which is installed on the foundation ground. The difference between a tower and a mast is that both are high-rise buildings, but mast has straps, while a tower has not. Towers received the greatest distribution due to its large diameters of blades and the impossibility of straps usage in that case.

Tasks related to the search for optimal structural forms of building structures for wind power units, as well as the development of methods for calculating them, are relevant for the energy industry and the national economy as a whole, since their solution will make it possible to save metal, reduce the anthropogenic load on the natural environment, and reduce the cost of electricity generation.

In this article, we consider interactions between the elements of the building system “steel tower - reinforced concrete foundation – foundation ground”. The literature analysis showed that there is currently no complete methodology for calculating such type of systems. To develop it, the following factors should be taken into account most fully:

- Physical non-linearity of material properties;

- Geometrical non-linearity of system elements (blades);
- Cyclic fatigue of materials (steel and concrete);
- Dynamic effects;
- Resonance phenomena;
- Friction between concrete and steel shell, as well as between concrete and ground.

2 Instruments and methods

It is not yet possible to completely describe the impact of all the listed factors, as is shown in the existing standards for the design of wind turbines [1, 2]. However, there is a powerful tool, i.e. computer simulation in ANSYS. In [3] we used this tool to study the system "steel power pole - the foundation – foundation ground". As opposed to that paper, the following features are taken into account in the system considered here:

- Wind load on the swept surfaces of rotating blades, an important characteristic of which is not pressure, but the wind flow speed;
- The existence of a concrete floor in the trunk of the tower;
- Frictional forces between the steel shell and the concrete core.

The latter two circumstances transform the trunk of a high-rise structure into a so-called pipe-concrete structure. Note that pipe-concrete is a composite material, which has some advantages [4, 5], and significantly increases the operational properties of wind

* Corresponding author: sabitov-kgasu@mail.ru

power plants, including strength, reliability and durability:

1. The external steel shell pipe simultaneously performs the functions of both longitudinal and transverse reinforcement, and it is capable of receiving forces in all directions and at any angle.

2. Lateral compression tube concrete core prevents the development of microcracks in the concrete separation, which attempt to expand in the radial direction of action of the vertical loads. There is a so-called clip effect, which increases the strength of concrete in compression by 50-80%.

3. Steel pipe is protected from buckling as concrete is pressurizing it from the inside.

4. In a pipe structure, it becomes effective to use high-strength concrete of B 60 class and higher. At the same time, due to the compression of concrete by the pipe, its typical brittleness of high-strength concrete class, is reduced.

5. Filling a steel pipe with concrete protects its inner surface from corrosion and increases the resistance to indentation during impact.

6. The fire resistance of the pipe-concrete elements is significantly higher than that of metal, and with an outer diameter of 400 mm it is about 2 hours without any protection, and when applying a protective shell it is possible to provide almost any desired fire resistance.

However, along with these, there are drawbacks that nonetheless can be easily removed with minimal additional costs. The most significant disadvantage is the difficulty of ensuring the joint operation of the concrete core and the outer steel shell under operational loads. Due to the difference in the coefficients of lateral deformation of concrete and steel ($\nu_b \approx 0.18$ vs 0.25 , vs ≈ 0.3), under such conditions the concrete core and steel cage work inefficiently.

In the process of gradually increasing the compressive force applied to the concrete structure, the core and holder work together only in the initial period of time. After this the outer shell tends to detach from the surface of the concrete, contributing to the appearance of radial tensile stresses in it. As a result, the effect of lateral compression and, accordingly, hardening of the concrete core disappears, and it becomes impossible to fully utilize the compression resource of the steel shell due to the presence of longitudinal forces in it. Concrete begins to work separately from the shell under conditions of uniaxial compression, and the pipe acts only as longitudinal reinforcement. A factor that can contribute to this process is concrete shrinkage. It is known that the shrinkage of concrete hardening in a steel tubular sheath is substantially less than the shrinkage of concrete hardening in air. Moreover, during the first years of hardening, the concrete core swells. Further shrinkage deformations depend on a number of factors, such as the composition of the concrete mix, the climatic parameters of the environment, and the geometric dimensions of the concrete elements themselves.

To eliminate this drawback of concrete, the following solutions can be applied (both separately and in combination):

- To weld special steel anchors on the inner surface of the shell pipe;
- Usage of concrete mix expanding non-shrink cement for manufacturing;
- To make a pipe-concrete construction with an annular cross-section: with an external and internal shell of a steel pipe with filling the space between them with concrete.

3 Results and Discussion

As an example, we consider a 2 MW wind turbine from work [6], which is shown in fig. 1.

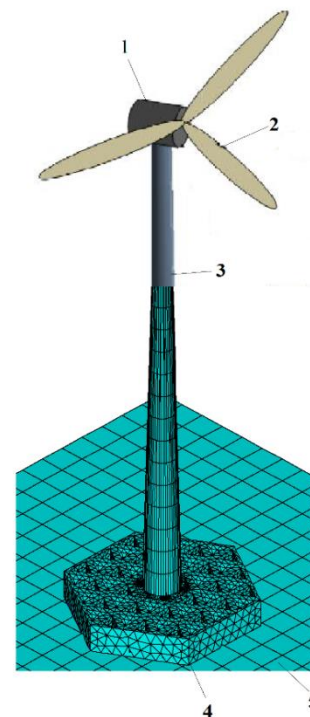

Fig. 1. Constructive scheme of 2 MW wind turbines (computer model in ANSYS): 1 - nacelle; 2 - rotor blades; 3 - tower; 4 – collapsible foundation; 5 - base ground.

The installation has the following characteristics: rotor radius $R = 41$ m, total height $H = 80$ m, height to the bottom of the nacelle is 76.7 m, mass of each blade is 5.78 t, mass of the rotor is 32.34 t, mass of the nacelle is 52.5 t. The loads acting on the wind turbine design are: the own weight of the tip ($P_1 = 100$ t, is applied at the top); own weight of the trunk ($P_2 = 334$ t, evenly distributed in height), the traction force caused by the wind flow incident on the blade ($F_t = 79$ t).

The tubular sheath is made of S355 steel, has a wall thickness of 50 mm, the diameter at the bottom 12 m, the top tapering of 7 m. Unlike the analog [6], in this work the lower part of pipe is filled with concrete of B60 class up to a height mark of 20 m. The second distinguishing feature of the wind turbine is the use of collapsible foundation, which is manufactured according to patent [7]. The general view of the foundation is shown in fig. 2. Its economic efficiency can be ensured not only by low labor intensity during assembly and disassembly and

low transportation costs (this is stated in the text of the patent), but also in a calculated way in assessing the stress-strain state of the “steel tower - reinforced constructive foundation – foundation ground” system taking into account their collaboration.

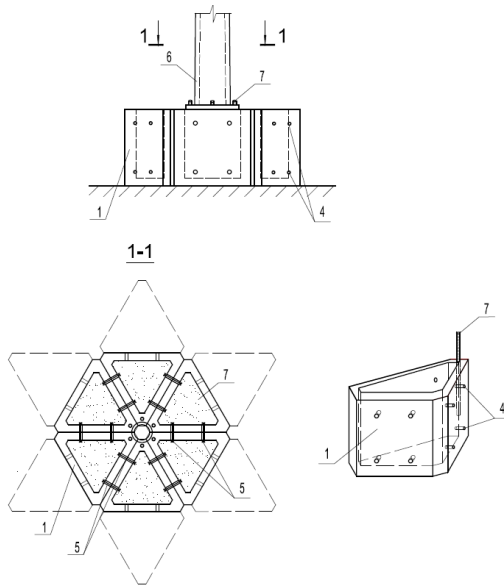

Fig. 2. General view of the collapsible foundation [7].

The ground of the foundation in the place of installation of the supports may be different, we will consider the worst option, which is allowed by the building Standards 22.13330.2011 "Foundations of buildings and structures" with the following characteristics: type of ground is clay, unsettled, non-swelling; porosity coefficient is 0.95; modulus of deformations $E = 8 \text{ MPa}$; turnover index $I_L = 0.5$; soil adhesion is 15 kPa ; internal friction angle $\varphi = 17^\circ$; the

calculated resistance $R_0 = 150 \text{ kPa}$; foundation stiffness coefficient (bed ratio) $k = 10 \text{ MPa/m}$ [8].

The considered system includes elements formed from materials with qualitatively and quantitatively different physical-mechanical properties. For simulation of the corresponding types of finite elements and the laws of deformation the ANSYS was used. Their list is presented in Table. 1.

Fig. 3 shows the deformation diagrams of materials used to create the model.

Mathematical expressions describing diagrams from fig. 3 (a,b) are:

$$\begin{aligned} \sigma_{bt} &= a_t (1 - b_t D_{bt})^{c_t} E_{bt} \varepsilon_{bt} \\ \sigma_b &= a_c (1 - b_c D_b)^{c_c} E_b \varepsilon_b \end{aligned} \quad (1)$$

where $D_{bt} = \frac{\varepsilon_{bt}}{\varepsilon_{bt2}}$ is the deformation criterion of damageability of stretched concrete; ε_{bt} , ε_{bt2} is the current and ultimate relative deformations for stretched concrete, respectively; $D_b = \frac{\varepsilon_b}{\varepsilon_{b2}}$ is the deformation criterion of damageability of compressed concrete; ε_b , ε_{b2} is the current and ultimate relative deformations for compressed concrete, respectively; $a_t = \frac{2.7R_{bt}}{E_{bt}\varepsilon_{bt0}}$, $b_t = \frac{1}{50R_{bt}}$, $c_t = 50R_{bt} \frac{\varepsilon_{bt2}}{\varepsilon_{bt0}} - 1$, $a_c = \frac{2.7R_b}{E_b\varepsilon_{b0}}$, $b_c = \frac{1}{50R_b}$, $c_c = 50R_b \frac{\varepsilon_{b2}}{\varepsilon_{b0}} - 1$ is the calculated coefficients, which, nevertheless, have a clear physical meaning; ε_{bt0} , ε_{b0} are the relative deformations

Table 1. To the construction of a finite element model.

QE Model Parameter	Tower of steel and pipe concrete	Reinforced concrete foundation	Foundation ground
Geometrical dimensions	Round steel pipe of variable cross section in the baseline, the lower part of which is filled with B 60 concrete	Regular hexagon in the baseline with a side of 9 m, a height of 1.8 m, consisting of prisms with a base in the form of a regular triangle with a side of 1.8 m.	Array 10x10x10 m
Type of finite element	Shell 181 is for pipe; Solid 65 is for concrete; Target 170 is for the contact zone surface (concrete), Conta 174 is for the contact surface (steel)	Solid 65	Solid 45
Deformation law	Two-line diagram; kinematic hardening with a Baushenger effect for a pipe; Curvilinear diagram from Radaykin [9] for concrete. In the contact zone, friction coefficient is 0.35, limiting deformations are 15%	Curvilinear diagram from Radaykin [9]	Determined by strength theory
Strength theory	Von Mises for pipe, William-Varnack for concrete	William-Varnack	Drucker-Prager

corresponding to the vertex stresses under tension and compression.

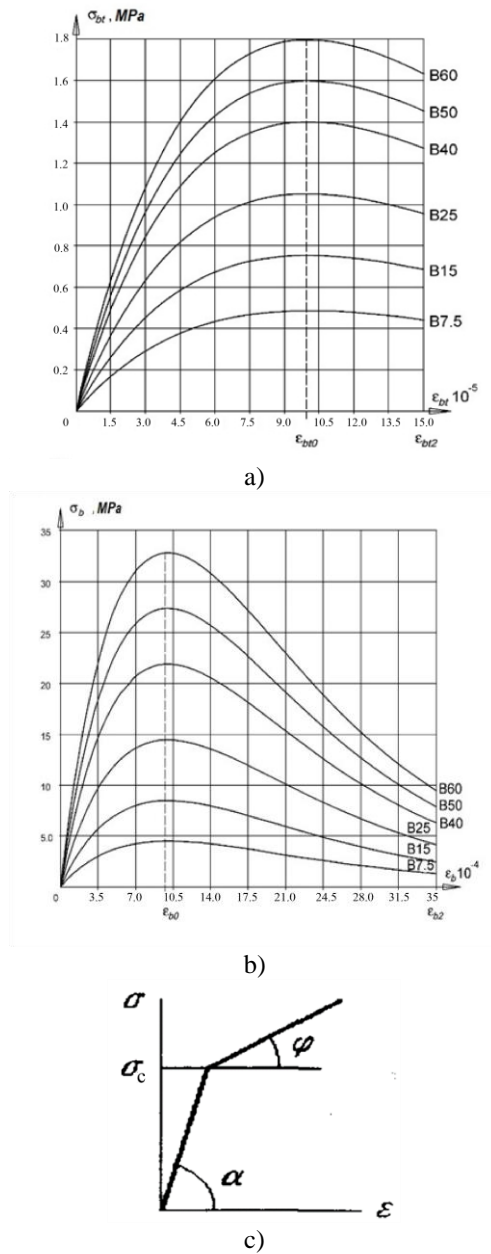

Fig. 3. Material deformation diagrams: a) curvilinear diagram under tension from [9]; b) curvilinear diagram in compression; c) two-line diagram, kinematic strengthening with the Bauschinger effect.

The bilinear diagram of kinematic hardening was adopted as the law of deformation for steel (see. Fig.3,c). The law assumes that in the σ - ϵ diagram, the sum of stresses of a different sign during the load-unloading process is always equal to twice the yield strength σ_y , that is, the Bauschinger effect is taken into account. The model is recommended for elastic-plastic problems with small deformations of material, subject to the von Mises yield condition:

$$\sigma_{eq} = \frac{1}{\sqrt{2}} \sqrt{(\sigma_1 - \sigma_2)^2 + (\sigma_2 - \sigma_3)^2 + (\sigma_3 - \sigma_1)^2} \leq \bar{\sigma}_{yn}, \quad (2)$$

where σ_{eq} is the von Mises equivalent, $\sigma_1 \geq \sigma_2 \geq \sigma_3$ are main stresses, $\bar{\sigma}_{yn}$ is the normative average limit of plasticity, taking into account the variation coefficient of 5%.

Thus, the physical law of deformation of a thin-walled shell was described by four parameters: the modulus of elasticity $E=206 \cdot 10^3$ MPa, tangential module $E'=75 \cdot 10^3$ MPa, yield strength $\bar{\sigma}_{yn} = 355$ MPa and Poisson's ratio $\nu = 0.3$.

To determine the dimensions of the foundation, a single support was preliminarily calculated as a rigidly mounted cantilever rack, that is, without regard to the foundation and foundation ground. This calculation was made in "Lira-SAPR 2017" taking into account all the features of the building Standards. The result was the load on the edge of the basement, which, using the formulas of the building Standards 22.13330.2011 "Foundations of buildings and structures" allowed calculating the required dimensions of the foundation: 9x9 m, height 1.8 m.

4 Conclusions

The results of determining the equivalent stresses in the tower are shown in Fig. 4.

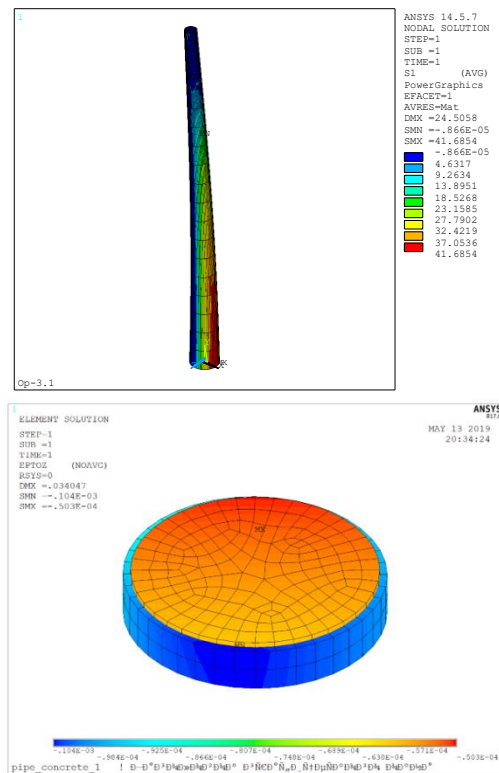

Fig. 4. Results of computer simulation of the tower.

Comparison of the calculation results with the data of [6,9-11] showed that the failure load of the tower increased by 57% due to filling the lower part of it with concrete, which indicates the efficiency of the proposed solution.

References

1. STO 70238424.27L00.059-2009 Wind power plants. Conditions for creating. Standards and requirements. Moscow: Non-Profit Partnership "Innovations in the power industry", 2009. - 192
2. STO RusHydro 03.01.102-013 Wind power stations. Basic requirements, criteria for the selection of wind power equipment for wind power plants. Moscow: OJSC "RUSHIDRO", 2013. - 100 p
3. Yu.M. Strelkov, O.V. Radaykin, L.S. Sabitov, I.L. Kuznetsov, Comparative analysis of static work of various types of steel supports of overhead power lines on the basis of computer modeling system "support-foundation-soil base, Constructionka mechanics and structures calculation, **1**, 71-79 (2019)
4. I.A. Duvanova, I.D. Salmanov, Pipe-concrete columns in the construction of high-rise buildings and structures, Construction of unique buildings and structures, **6(21)**, 89-103 (2014)
5. A.I. Kikin, R.S. Sanzharovsky, V.A. Trull, *Constructions made of steel pipes filled with concrete*, 144 (1974)
6. K.N. Umesh, P. Bharath, F.I. Mohamed, Design and analysis of 2-MW wind turbine tower, International Journal of Mechanical And Production Engineering, **4(10)**,13-17 (2016)
7. The patent of the Russian Federation № 2633604, 12/04/20 16 . Collapsible foundation for the support of Russia // Patent № 2633604. 2017. Bull. No. 29. / Sabitov L.S., Kuznetsov I.L., Khusainov D.M., Sabirov S.I., Akhunova Z.R., Strelkov Yu.M.
8. Eds. A.A. Umansky, *Designer's Handbook*, **2**, 307 (1973)
9. O.V. Radaykin, To the construction of concrete deformation diagrams under uniaxial short-term tension, Bulletin of Civil Engineers, **6**, 71-78 (2017)
10. I.N. Khamidullin, L.S. Sabitov, I.L. Kuznetsov, Development and research of supports for wind generator installations, Scientific Bulletin of the Voronezh State University of Architecture and Civil Engineering. Construction and Architecture, **2(38)**, 34-40 (2015)
11. I.N. Khamidullin, L.S. Sabitov, I.L. Kuznetsov, Development and research towers for wind turbines, Scientific Bulletin of Voronezh State University of Architecture and Civil Engineering. Construction and Architecture, **4(28)**, 25-32 (2015)