

An assessment of the sewer tunnel stress-strain behavior during the reconstruction of an object of cultural heritage

*Alexander Ledyayev*¹, *Vladimir Kavkazskiy*^{1*}, *Dmitry Grafov*¹, *Dmitry Soloviev*¹, and *Andrey Benin*¹

¹St.Petersburg State Transport University, Moskovsky ave., 9, Saint Petersburg, 190031, Russia

Abstract. The article offers an information about the work carried out on technical monitoring of the city sewerage system tunnel in the framework of the actual problem of recreating the objects of cultural heritage of St. Petersburg, which fall into the protected zone of underground engineering networks. The purpose of the study is to identify values of the stress-strain state of the tunnel lining at various stages of construction of a cultural heritage object located on the earth's surface in the immediate nearness. For formation of a base of the analyzed values was undertaken geolocation of ground massive, conducted geodetic measurements, defined the deformation of the soil by inclinometer boreholes, was obtained graphs of precipitation the soil massive, developed by setup technology for strain gauge sensors linear displacement inside the tunnel, worked out the mathematical model in the specialized software. Analysis of the obtained results allowed us to associate values of the stress-strain state of the collector tunnel effect from the buildings under construction and structures, as well as to identify the actual task for further research to develop methods of rapid diagnosis of the stress-strain state of tunnel lining structures in terms of their special mode of operation.

1 Introduction

The erection of new capital structures within the established high-density development typical of St. Petersburg and its well-developed infrastructure is a pressing issue of city planning. The main technological challenges arising while implementing these projects are associated with the unique geological structure of the city ground, abundance of rivers, a large number of legally protected objects, and high density of general utilities.

Sometimes, the erection or reconstruction of objects having an industrial, civil, transport or other purpose affect the underground structures and communications. The mostly affected objects of the city infrastructure are such vital facilities as the water supply, sewer and cable networks equipped with tunnel-like collectors and located at the depth of 2 to 90 meters from the daylight surface. The total development of these networks accounts to several hundreds of kilometers [1, 2].

* Corresponding author: kavkazskiy_vn@mail.ru

The vast variety of collectors affected by the construction process contains a network of pipelines and tunnels, tunnel shafts, shield chambers and bore holes, emergency overflow facilities, etc. According to the functionality, the majority of the public utility tunnels refer to the water supply and sewage networks. Due to structural specificity of these collectors, the most common way of their erection is to arrange them under the road surfaces, in the right-of-way areas, along the river embankments, under the riverbeds, and in parks and recreational zones.

Capital construction implemented in the immediate proximity to the existing underground facilities (especially those of high economic value) and having a strong effect on them can result in a risk of malfunction of the essential city utilities, which in its turn can lead to serious negative consequences [2, 3]. Thus, an important engineering task is a thorough geomechanical, geophysical and geodetic study of the structures and the parameters of compensational stress relieving systems, which are designed to ensure safety and quality of works in the process of reconstruction of cultural heritage buildings with an effect on the existing tunnel communications. A solution to this problem can contribute a lot to the rational use of land in St. Petersburg.

The analysis carried out helped to detect 38 city locations where there is a future probability of re-erection of lost objects of cultural heritage. The major part of them accrues to the city center and adjacent districts of St. Petersburg (Fig. 1). The analysis showed that not less than 30% of the objects, which might be re-erected in the mid or long-term period, could have an effect on the existing sewer tunnels. In such cases a special individual approach is needed for reconstruction of cultural heritage objects. This approach should be capable of preserving the available genuine fragments of the lost buildings, ensuring safety of construction works, and minimizing the influence of construction on the technical condition of the sewer tunnels. The general industrial approaches to this kind of challenges are well-known. Nevertheless, the particular cases characterized by individual engineering and technical features present a great interest.

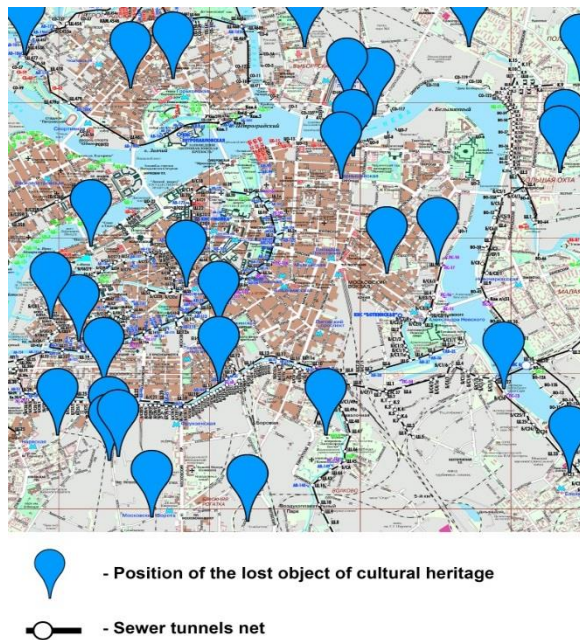

Fig. 1. St. Petersburg city center plan showing the lost objects of cultural heritage overlaying the scheme of tunnel-like water sewage networks

2 Description of the object of study

An example of modern approach to optimization of sewer tunnels performance while constructing surface buildings was shown by re-erecting of an object of cultural heritage – the Church of Our Lady Joy of All Who Sorrow, located at: 22–24, Obukhovskoy Oborony ave., Nevsky District, St. Petersburg (Fig. 2). The original building in the Russian Revival style was constructed in 1894–1898 to the project of architects A.I. von Hogen and A.V. Ivanov. In November 1932 the church was closed and later demolished. Once the archeological excavations were finished, the foundation of the lost church was declared a significant site of local relevance. In 2015 the re-erection work was begun. Working on the project solutions for re-erection of the cultural heritage building the specialists established that the church was located above the mainline sewer tunnel carrying waste water collected from the most part of the Nevsky District of St. Petersburg.

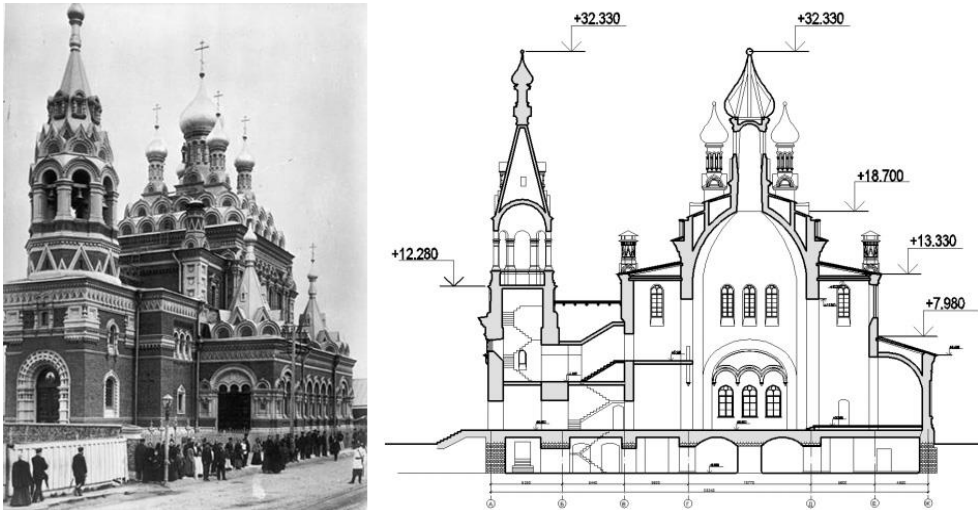

Fig. 2. The general view and the cross-section of the Church of Our Lady Joy of All Who Sorrow before demolition

In 1966 a need appeared in arranging waste water sewage system, which was caused by the active development of the left-bank part of the Nevsky District of Leningrad. So, a TKK23 sewer tunnel was constructed partly crossing the foundation of the church disassembled in 1933. The sewer tunnel structure consists of prefabricated reinforced concrete lining of circular cross-section having the diameter of 3,230 mm, equipped with reinforced concrete jacket and made up by shotcrete on steel lattice (Fig. 3). The part of the sewer tunnel affected by the church in the interval between shafts #1/27 and #18 is located at the depth of -4.80 m to -4.64 m and lies predominantly within weak quaternary deposits, which required applying special methods of work using caisson technology (tunneling with compressed air)[4].

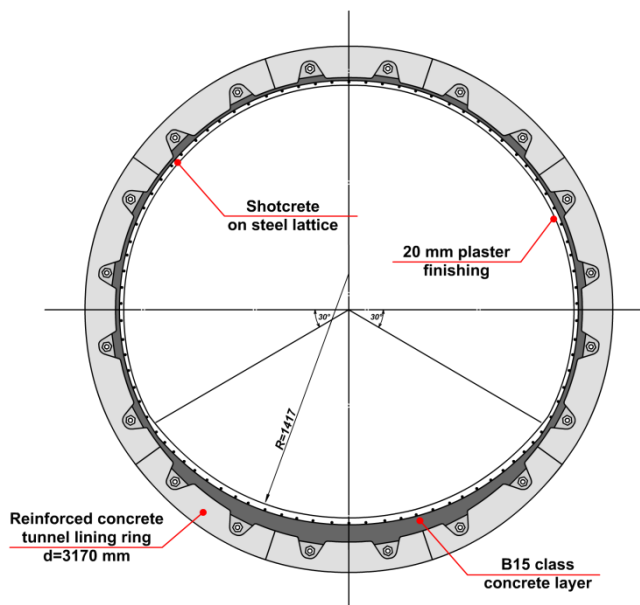

Fig. 3. TKK23 sewer tunnel lining cross-section affected by the re-erection of the object of cultural heritage

Today, the TKK23 sewer tunnel serves as an element of St. Petersburg sewage network and is the only mainline discharge of waste water collected from the left-bank part of the Nevsky District having no redundant sewage systems. This further contributes to the significance of monitoring the collector due to its operational conditions being changed. The average hourly flow rate within the considered interval equals to 5,500 m³ per hour at dry weather.

The main technological challenge, which aroused when re-erecting the church, was caused by a minor rock pillar lying between the preserved foundation and the sewer lining, the latter being less than 800 mm thick. Another trouble was weak host ground. The complexity of hydrogeological conditions of the construction site derived from several aquifers in the cross-section and the proximity of the Neva River. As it was crucial to retain the performance properties of the existing sewer, the preparatory and construction works were subject to very strong requirements.

The problem might have been solved by developing and implementing compensational stress relieving systems above the existing sewer tunnel, which were designed to minimize the impact of the newly-constructed building weight and to ensure safety of construction works. Thus, in the process of re-erecting the Church of Our Lady Joy of All Who Sorrow it was proposed to establish a bridging made of tubular girders with 530 mm in diameter that should have been installed within the rock pillar between the preserved foundation of the church and the existing sewer lining. Moreover, to decrease the load acting upon the sewer some reinforced concrete piles with casing pipes (800 mm in diameter) were sunk to the depth of 30 m. These had to withstand the admissible tunnel deformations by transferring the load from the church to the low-compressible bottom soil under the sewer [5, 6].

It was impossible to excavate the daylight surface in order to install a protection screen. Therefore, it was decided to apply closed tunneling technology, which implied jacking tubular sections through the ground with a hydraulic jack. For this purpose starting and

finishing pits with grooved bracing were arranged on the sides of western and eastern facades of the re-erected building (Fig. 4).

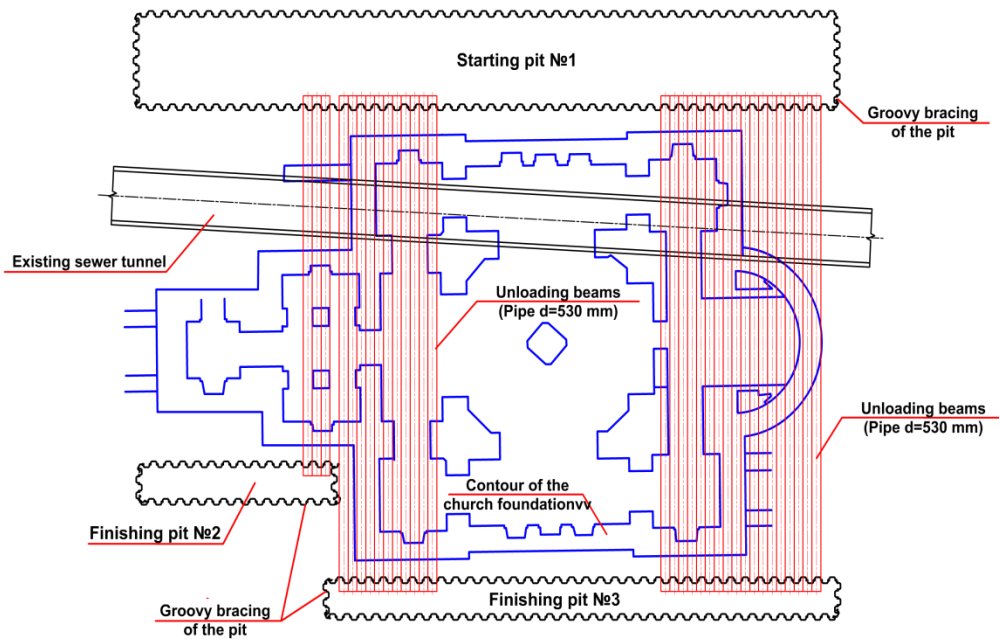

Fig. 4. Layout of reinforcement girders under the church foundation

3 The study and the analysis of its results

In the course of installing the stress relieving structure some serious drawbacks of the accepted solutions were detected. Thus, the works were suspended and it was decided to improve the project.

The operational analysis of the sewer tunnel structures and the host ground condition was contracted to the Tunnels and Underground Railways Department, Emperor Alexander I St. Petersburg State Transport University. In 2017–2019 the Department was monitoring the technical condition of the sewer lining. To ensure preservation of the sewer and to make provisions for real-time adjustment of the work schedule the Department organized a complex system of monitoring that involved geotechnical equipment designed for geodetic and automated control of the sewer technical condition [7].

Specialists of the Tunnels and Underground Railways Department processed materials of the sewer inspections, organized monitoring of the sewer technical condition, and developed a mathematical model of the existing sewer for the purpose of analysis. This mathematical model helped to swiftly estimate the influence of deformations on the stress-strain behavior of the sewer lining.

At an early stage of geotechnical monitoring preferential zones for placing recording devices were determined by means of geolocation in various cross-sections. This helped to specify the sewer lining parameters and to assess the condition of the surrounding host ground.

The further step included in-situ assessment of the sewer tunnel condition; at this stage geodetic marks were installed to provide monitoring of the ground and the church

foundation settlements. For this purpose the engineers developed a system of geodetic benchmarks that were attached to the reinforcement tubular girders jacked through the soil under the church foundation (Fig. 5);

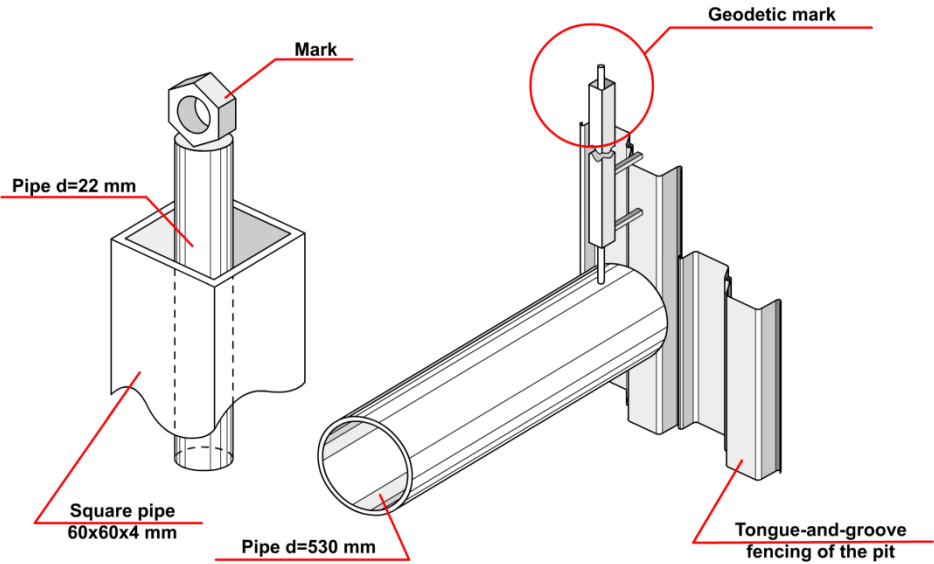

Fig. 5. A geodetic mark scheme

The analysis of data obtained while observing the geodetic marks resulted in the diagrams of the ground and the church foundation settlements (Fig. 6).

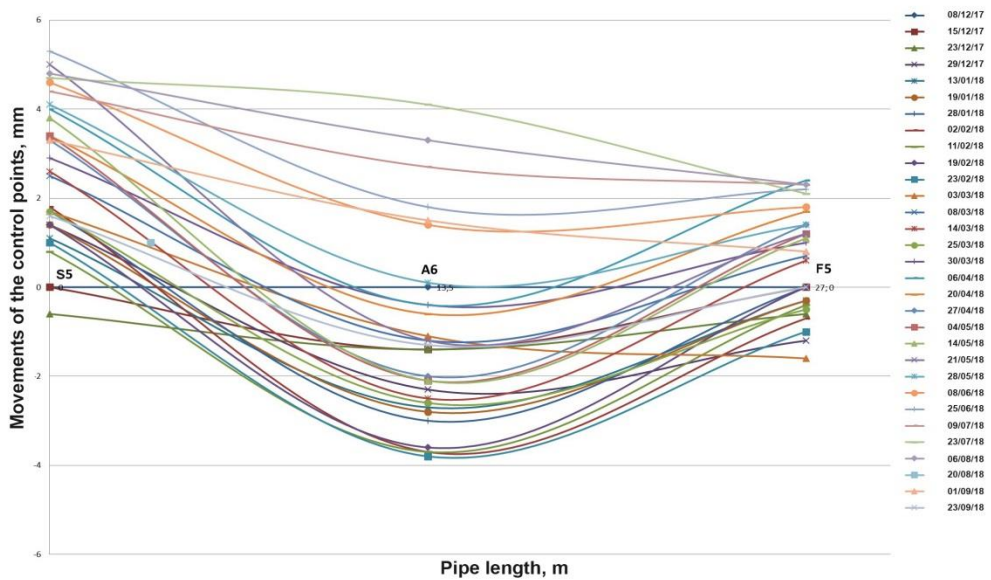

Fig. 6. A diagram of movements of geodetic marks control points

Thus, the monitoring performed from December 2017 to December 2019 showed that ground settlements within the project area occurred in two stages, which was explained by the technology applied for arranging pile foundation of the re-erected church. The

maximum benchmark settlements in the starting and finishing pits were -19.5 mm, whereas in the altar area of the church the settlement was -32.4 mm.

Further works were focused at ultrasonic tomographic identification of cavities beyond the lining and at installation of a system of strain-gauge motion sensors in the arch area of the tunnel, which could help to monitor the properties of the lining and to transfer the obtained data to the surface (Fig. 7). However, due to unstable ventilation within the actively used sewer tunnel installation of sensors appeared non-feasible.

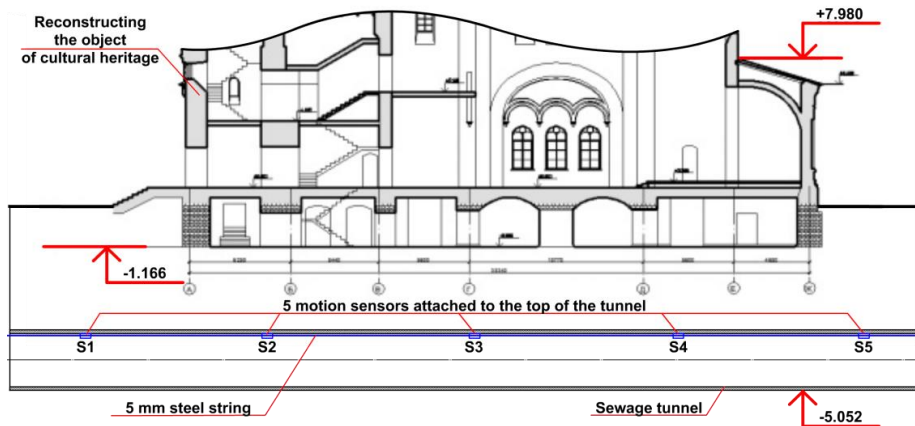

Fig. 7.

Installation layout of motion sensors within the sewer tunnel

For the purpose of real-time detection of deformations six survey bores were made around the sewer at the distance of 1 m from the tunnel lining, including four bores in the altar area of the church.

To collect objective and evident data on deformations the survey measurement bores were paired along the sewer axis and placed close to the church columns where the highest load was expected (Fig. 8).

In the course of study the maximum movements were detected at the survey bore #4, which accounted 3 mm at the 5–6 m depth along the sewer X-axis and 4 mm at the 5–6 m depth along the sewer Y-axis.

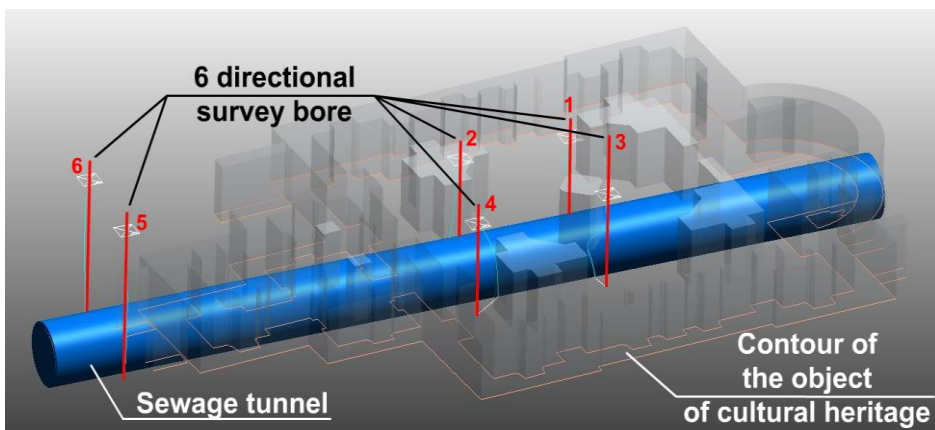

Fig. 8. Layout of survey bore sensors

In order to perform real-time analysis of the sewer lining stress-strain behavior and basing on the survey data and geodetic marks the specialists undertook mathematical simulation with Plaxis software. The task was being solved in two-dimensional formulation by means of finite elements (FE) method (Fig. 9).

With the area of construction process influence on the sewer tunnel having been considered, a fragment of soil was selected for calculation aimed at determining dependencies between the deflections of tubes with benchmarks and the strains in the lining. These helped to obtain a strain figure of the soil and the lining (Fig. 10) and to formulate evaluation criteria for the construction works undertaken in the process of re-erecting the surface building [8].

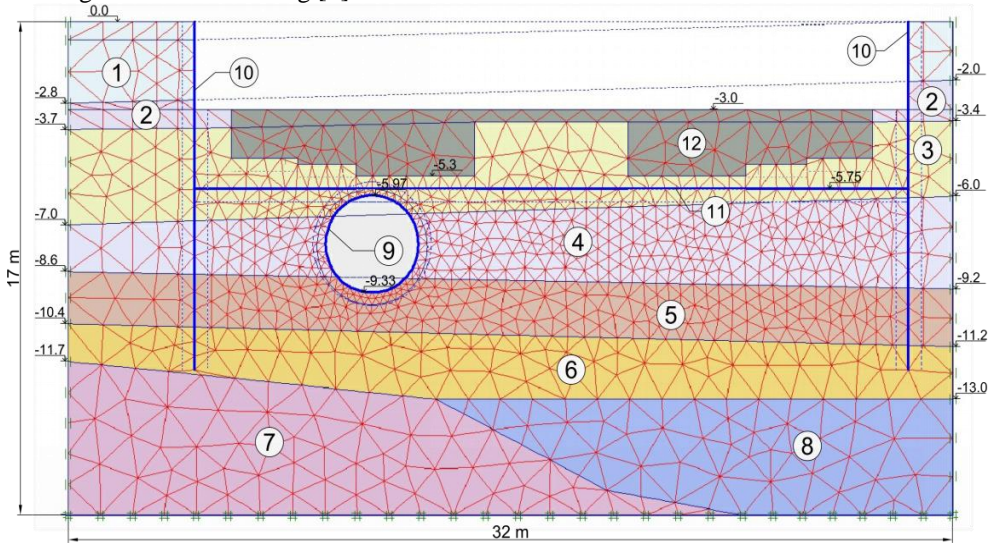

Fig. 9. The accepted analytic model: 1 – fill-up ground: soft sandy loam; 2 – silty sand; 3 – very soft loam; 4 – banded sluffing soft loam; 5 – banded sluffing soft loam; 6 – very soft laminated loam; 7 – soft sandy loam; 8 – semi-solid soft loam; 9 – sewer lining; 10 – grooved bracing; 11 – pipe, Ø530 mm; 12 – existing foundation of the church.

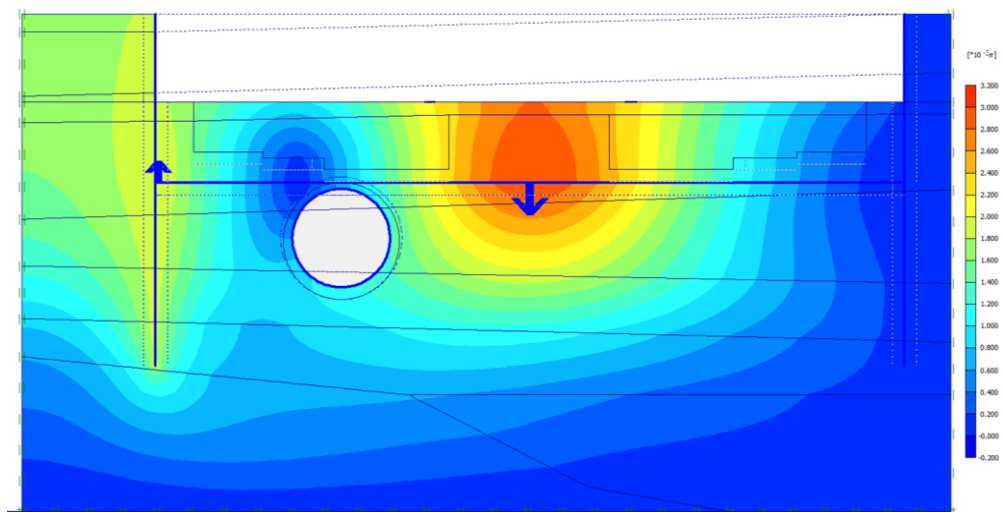

Fig. 10. Strain figure according to the results of geodetic monitoring.

4 Conclusion

The undertaken complex of in-situ assessments helped to detect indicators of the sewer tunnel stress-strain behavior at different stages of re-erection of the cultural heritage building. The analysis showed that the negative impact produced on the sewer tunnel lining was minimized by the accepted technology of foundation reinforcement. Nevertheless, today in St. Petersburg we see a distinct trend of re-erecting objects of cultural heritage located in the exclusion zones of sewer tunnels. So, the challenge remains unchanged; and it requires developing methods of real-time diagnostics of stress-strain behavior of tunnel linings operating in a special mode that is characterized by daily and seasonal variability of waste water level and by increased gas contamination of the interior space. Due to these factors sometimes it is impossible to perform monitoring inside the underground facility, which in its turn reduces integrity and trustworthiness of the structural state assessment. It is especially relevant as far as the spatial behavior of the structure is concerned, when the maximum tensile stress appears in the bottom zone of the tunnel that is beyond the reach of visual and instrumental control [9]. It should also be noted that during the tunnel operation period this kind of stress can result in the lining consistency defects, which can lead to water leakage outside the lining and further expansion of soil and – in the long run – additional soil settlements.

Based on the abovementioned, the aim of further improvement of the stress-strain behavior assessment methods applied to the sewer tunnels lining is increasing their objectiveness. This could be reached by analyzing results of mathematical simulation in three-dimensional formulation.

References

1. M. Grygierek, P. Kalisz, *Journal of Sustainable Mining* **17** (2), 56-67 (2018). DOI 10.1016/j.jsm.2018.04.001
2. Report. Tahmoor Colliery longwalls 25 to 26. Sydney water sewer infrastructure. Surface safety and serviceability management plan Report No. MSEC286-0404. (2008). Available at: <http://www.tahmoorcoal.com.au/en/publications/approvals/LW26/LW26-SSSMP-Sydney-Water-Sewer-Rev-F.pdf>.
3. F.G. Bell, L.J. Donnelly, *Mining and its impact on the environment* (1st ed.). (London, New York, Taylor & Francis, 2006).
4. E.Yu. Kulikova, *Gornyi informatsionno-analiticheskiy bulletin* **8**, 21–28 (2007). DOI 10.24412/Ffcvp_tsXoU
5. J.-V. Valdenebro, N.G. Faustino, J. J. López, *Tunnelling and Underground Space Technology* **89**, 38-49 (2019). DOI 10.1016/j.tust.2019.03.026
6. G. Attard, Y. Rossier, T. Winiarski, et. al., *Land Use Policy* **64**, 461-469 (2017). DOI 10.1016/j.landusepol.2017.03.015
7. L. Von der Tann, R. Sterling, et. al., *Underground Space* DOI 10.1016/j.undsp.2019.03.003
8. G.G. Gschwandtner, R. Galler, *Tunnelling and Underground Space Technology* **78**, 159-167 (2018). DOI 10.1016/j.tust.2018.04.030
9. A. Benin, A. Konkov, V. Kavkazskiy, et. al., *Procedia Engineering* **165**, 1483-1489 (2016). DOI 10.1016/j.proeng.2016.11.883