

Sewage cleaning by using a phase separator

Nikolay S. Serpokrylov¹, Alla S. Smolyanichenko¹, Elena V. Yakovleva^{1,*}

¹Don State Technical University, 1, Gagarin square, 344000, Rostov-on-Don, Russia

Abstract. This article proposes a solution to the urgent problem of treating oil-, fat-containing wastewater. A phase separator of dispersions for preliminary purification of industrial wastewater contaminated with fats is proposed, its effectiveness in the treatment of wastewater at local treatment facilities of an industrial plant for the production of sunflower oil is tested. In order to reduce the cost of acquiring reagents and increase the efficiency of purification of fat-containing wastewater, the use of carbide sludge and sodium hydroaluminat was studied. Laboratory studies conducted by the method of an active experiment.

1 Introduction

In the framework of import substitution, the issue of treating industrial wastewater (IWW) and waste disposal is more relevant. The deteriorating environmental situation is forcing stricter requirements for the discharge of waste and wastewater from enterprises (Table 1).

Table 1. Normative indicators of the general properties of wastewater and allowable concentrations of pollutants in wastewater that are allowed to be discharged into centralized alloy and domestic wastewater systems.

	Name of indicator of pollutant	Unit of measurement	The maximum allowable value of the indicator and (or) concentration in a natural wastewater sample
1.	The reaction medium (pH)	un.	6.0 – 9.0
2.	Mineralization (solid residue)	mg/dm ³	3000
3.	Fats (dissolved and emulsified)	mg/dm ³	50
4.	Petroleum products (dissolved and emulsified)	mg/dm ³	10
5.	Sulfides(S-H ₂ S+S ²⁻)	mg/dm ³	1.5
6.	Chlorine and Chloramines	mg/dm ³	5.0
7.	Suspended matter	mg/dm ³	300

*Corresponding author: anas199021@yandex.ru

8.	BOD ₅	mg/dm ³	300
9.	COD	mg/dm ³	500
10.	Nitrogen (organic and ammonium)	mg/dm ³	50
11.	Phosphorus common (P _{tot})	mg/dm ³	12
12.	Anionic surfactants	mg/dm ³	10
13.	Phenols (amount)	mg/dm ³	0.25
14.	Sulphates (SO ₄ ²⁻)	mg/dm ³	300
15.	Chlorides (Cl ⁻)	mg/dm ³	1000
16.	Aluminum(Al)	mg/dm ³	3
17.	Iron (Fe)	mg/dm ³	3
18.	Manganese (Mn)	mg/dm ³	1
19.	Copper (Cu)	mg/dm ³	0.5
20.	Zinc (Zn)	mg/dm ³	1.0
21.	Common chrome (Cr(III) +Cr(VI))	mg/dm ³	0.5
22.	Nickel (Ni)	mg/dm ³	0.25
23.	Cadmium (Cd)	mg/dm ³	0.015
24.	Lead (Pb)	mg/dm ³	0.25
25.	Mercury (Hg)	mg/dm ³	0.005

To achieve these requirements, the search and development of the most effective solutions in the field of IWW purification is required [27-30].

The solution to this problem for already built local treatment facilities of enterprises (LTF), but which do not meet the requirements for the discharge of wastewater into sewage systems, is their retechnology [1, 2-6].

According to the data of the All-Russian Research Institute of Fats of the Russian Academy of Agricultural Sciences (RAAS) [7], the concentration of fats, mg / l, in the greasy wastewater (GWW), depending on the production, are: oil extraction - 200, hydrogenation - 100, refining - 20,000, margarine - 7000, mayonnaise - 16,000, soap making - 20,000, glycerol and fatty acids - 150. In the designer's reference book [8], fat concentrations up to 2,000 mg / l are typical for the food industry, and therefore we consider these data to be outdated.

2 Materials and Methods

The studies were carried out in laboratory and pilot conditions on real wastewater of a plant for the production of vegetable oil in the Rostov region, control was carried out according to the parameters: suspended solids, fats, transparency, sediment / clarified water height, pH.

Analysis of the samples was carried out in an accredited laboratory.

Testing the effectiveness of reagent wastewater treatment was carried out at the LTF of an industrial plant for the production of vegetable oil in the Rostov Region. The wastewater generated in technological processes of the enterprise mainly contains fats (up to 30,000 mg/l) and suspended solids (up to 25,000 mg/l) - Fig. 1.

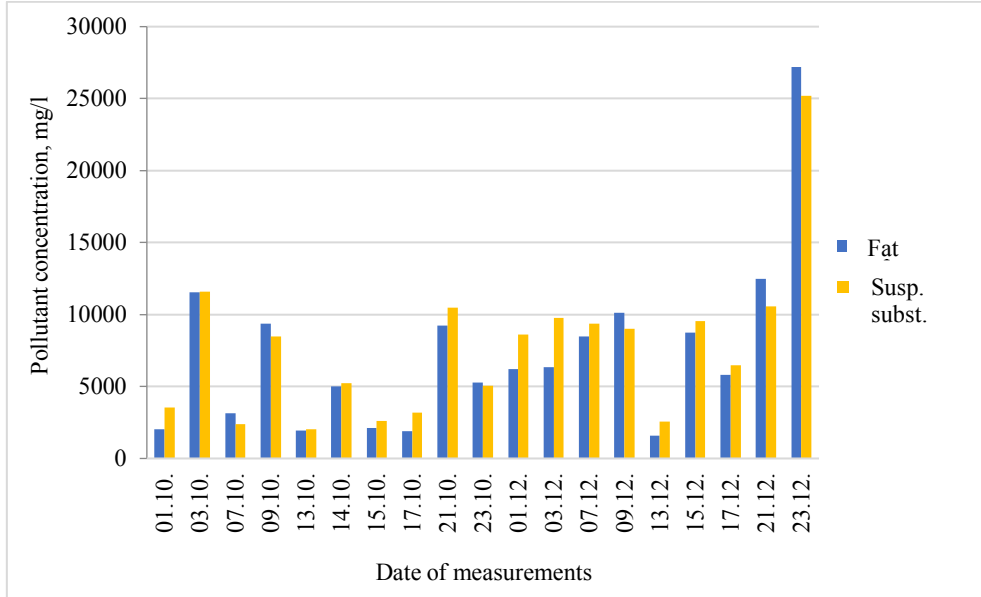

Fig. 1. Concentration of the main pollutants in the wastewater of a plant for the production of sunflower oil (average daily sample).

Note: pH is in the range of 6.0-8.8.

The capacity of the treatment plant is about 7000 m³ / day. Fluctuations in consumption by the hours of the day are shown in the graph (Fig. 2)

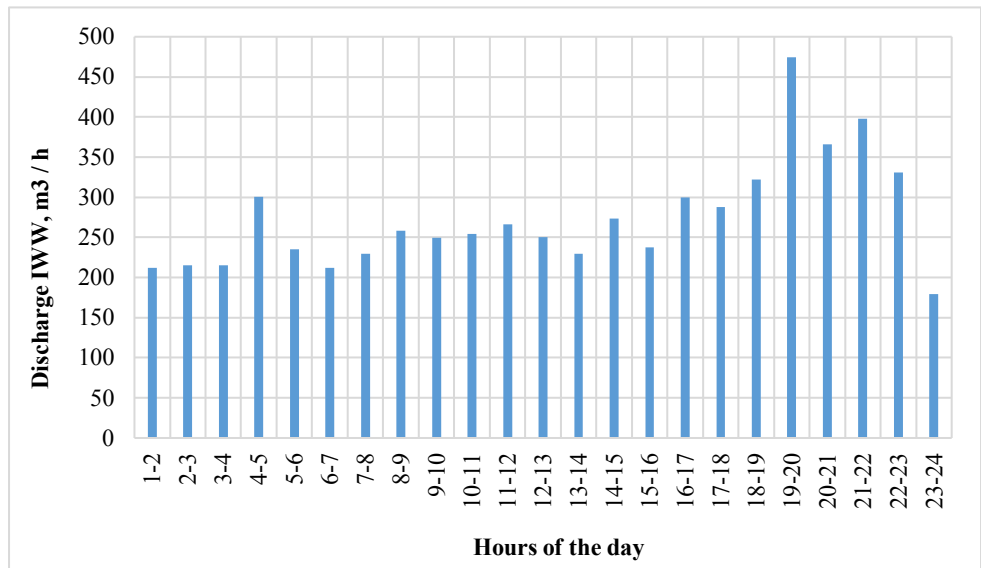

Fig. 2. Total hourly average IWW inflow over the observation period (14 months 2013-2014).

The LTF uses the technology of physico-chemical cleaning of IWW using a pneumatic flotator, a horizontal sump with a block of thin-layer modules, a clarified water tank, vertical sumps, ruff filters and a reagent farm, which includes a solution / supply tank and a dosing system. Empirically established the residence time of the waste fluid in each structure and in pipelines, which is 120-125 minutes (Fig. 3).

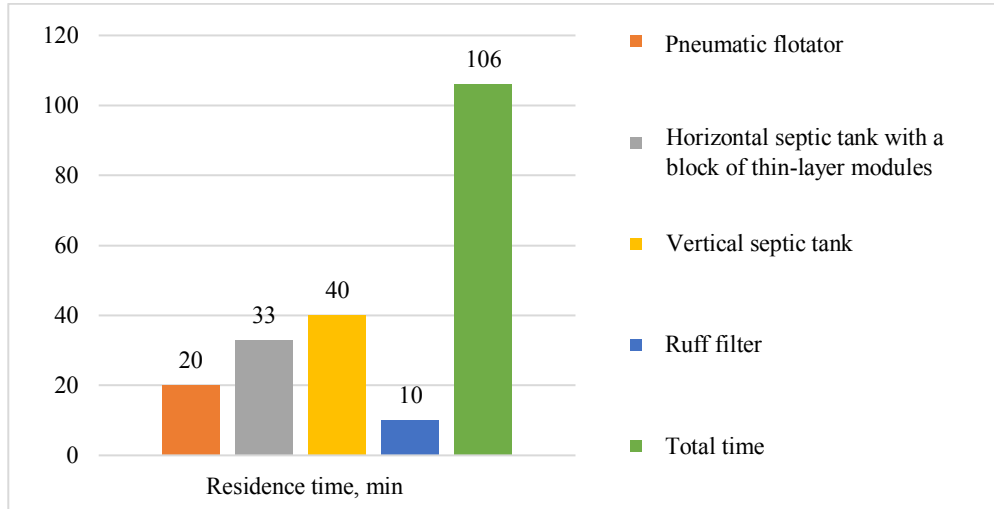

Fig. 3. The time spent by IWW on the stages of cleaning on the VOC of the enterprise.

Currently, the quality of treated wastewater at LTF does not correspond to the established temporarily permissible concentrations of pollutants (TPC) for admission to the city sewage network [9]. This leads to an increased charge for discharge of pollution, as well as (for volley discharge) poisoning of activated sludge at the city aeration station and the withdrawal of aerotanks from operating mode for 1-1.5 months.

To choose the best purification technology, it is necessary to know the nature of the fat, the composition of fatty acids, the physicochemical properties of the main components (lipids, proteins, carbohydrates) and their chemical transformations during the purification process, the nature of impurities and related substances, the phase-dispersed state of fat-containing wastewater (FSW) and their indicators (pH, temperature, concentration, water hardness and other factors), as well as physicochemical phenomena occurring at the phase boundary.

Machiginov V.S. a classification of fatty and related impurities in WLW has been proposed [7], which develops the well-known classification of Academician L. Kulsky A. [10]. It is based on the concept of the phase state of a substance in an aqueous medium, which, to a certain extent, is determined by its dispersion (table 2).

Table 2. The Classification of impurities FSW according to their phase-dispersed state [7].

Indicators	Systems			
	heterogeneous		homogeneous	
	I	II	III	IV
The state of substances in water	Suspensions (suspensions and emulsions), insoluble in water and causing turbidity RAAS	Colloidal solutions: hydrophilic and hydrophobic colloids and macromolecular substances that determine the	Molecular solutions: dissolved gases in liquid alcohol and molecular soluble organic	Ionic solutions: substances that dissociate in water into ions

		oxidizability and color of LSW	compounds, which give the liquid smell, taste and color	
Particle dispersion	$>10^{-5}$ - 10^{-4} sm or >0.1 - 1 mkm or >1000 - 10000 A°	$>10^{-6}$ - 10^{-5} sm or >0.01 - 0.1 mkm or >100 - 1000 A°	$>10^{-7}$ - 10^{-6} sm or >0.001 - 0.01 mkm or >10 - 100 A°	$>10^{-8}$ - 10^{-7} sm or >0.0001 - 0.001 mkm or >1 - 10 A°
Components	Vegetable oils and animal fat (triglycerins), soap micelles, protein-mucous complex, high molecular weight fatty acids, clay, carbonate rocks, silt, fine sand, sparingly soluble metal hydroxides, suspended organics	Simple (waxes) and complex (phospho- and glycolipids, proteins, carbohydrates, surfactants and non-dissociated forms of VHS staining substances: gossypol, sesamol, glycosides, thioglycosides, carotenoids, chloroform), humic and fulvic acids and their ammonium and sodium salts, soaps	Low molecular weight fatty acids, glycerin, alcohols, hydrocarbons, aldehydes, ethers, vitamins, pigments, phenols	Salts, acids, bases, giving water rigidity and alkalinity, phosphatides, sodium salts of fatty acids
Membrane technology	Microfiltration	Ultrafiltration	Nanofiltration	Reverse osmosis

FSS includes all four groups of impurities and is a complex multicomponent polydisperse system containing large and small suspended solids, colloidal, molecular and ion-soluble substances. This order of groups with increasing dispersion implies a sequence of purification steps and, first of all, the removal of coarse impurities and colloidal particles. Thus, by removing the first group of particles by sedimentation or reagent-free flotation, and the second by ultrafiltration, in most cases, the purification of vital substances by the concentration of fatty substances corresponding to the normative indicators can be achieved.

This approach is implemented in a plant for pre-treatment of wastewater containing dispersed contaminants in the form of solid, liquid and gaseous phases or their combinations; a phase dispersion separator (PDS) has been proposed [11-13].

The phase separator (Fig. 4) is a rectangular tank divided by partitions into successively connected compartments: a hydrophobic filter, aeration, a settling tank with a coalescent filter at the inlet with a dedicated wastewater mixing chamber with a reagent solution and flocculation and adjustable thin-layer modules.

Note. When designing the PDS, the recommendations [14, 15] were taken into account regarding the residence time of water in each zone, the fluid flow rate, overall dimensions and the utilization factor of the volume of the structure, the design of the zone of thin-layer sedimentation, the angle of inclination of thin-layer modules and the material of their manufacture.

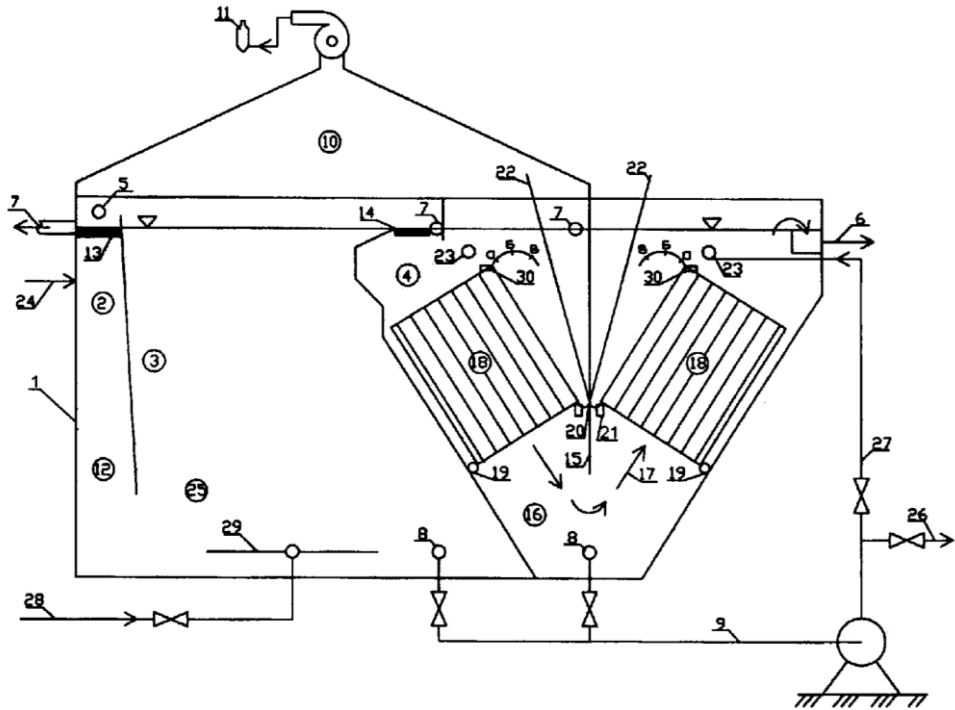

Fig. 4. Phase separator of dispersions for wastewater treatment.

Where: 1 - tank in the form of a tank with an inclined bottom, 2 - coarse treatment unit, 3 - medium treatment unit, 4 - fine treatment unit, 5 - sewage supply and distribution pipelines, 6 - sewage drainage pipeline, 7 - collection and discharge pipelines floating pollutants, 8, 9 - pipeline for collection and removal of sedimentary pollution, 10, 11 - zones for the allocation, collection, removal and purification of gas impurities of wastewater, 12 - mixing chamber, 13 - coalescence filter of the coarse treatment unit, 14 - coalescence filter of the medium assembly cleaning, 15 - vertical burnout not reaching the bottom Single, 16, 17 - zone downstream and upstream of wastewater, 18 - movable in the vertical plane of the thin-film modules 19 - thin hinge support modules, 20 - flexible dividing aprons, 21, 22 - openings and rods in aprons, 23 - flushing pipes for thin-layer modules, 24 - reagent supply pipe, 25 - flocculation chamber, 26 - sludge discharge pipe, 27 - flushing fluid supply pipe to thin-layer modules, 28 - air supply pipeline, 29 - fine aerator, 30 - rotary drive of thin-layer modules.

In the PDS (Fig. 4) wastewater is supplied containing contaminants in the form of suspended, emulsified and gaseous impurities (suspended solids, oils, oil products, fats, hydrogen sulfide, etc.).

The coalescent filter of the coarse treatment unit is formed from a floating layer of hydrophobic treated wastewater pollution. Emulsified (liquid) wastewater contaminants that are dispersed, passing through a layer of the same pollutants having the same surface tension, coarsen and, in the bulk, coalesce, i.e. pass from a dispersed state into a volume. The increase (excess) of the hydrophobic layer of the coalescent filter is discharged.

In the flocculation chamber, colloidal particles of a coagulant are formed, which adsorb suspended contaminants, and with the supply of air through a finely dispersed aerator, gaseous impurities are blown into the zone of allocation, collection, discharge and purification of gas wastewater impurities. Gaseous impurities released from the wastewater

(hydrogen sulfide, mercaptans, ammonia, etc.) are discharged to the gas impurity treatment unit.

The wastewater freed from gas impurities with the formed flakes from the secondary treatment unit enters the fine treatment unit. Thin-layer modules are mounted in a countercurrent circuit: with a downward flow for the separation of dispersed contaminants with a density of less than 1 and with an upward flow for the separation of dispersed contaminants with a density of more than 1.

Depending on the concentration and ratio of treated wastewater contaminants during commissioning, the installation determines the optimal angle of inclination of thin-layer modules using a rotary drive in position a, b or c.

To conduct research on the PDS operation mode, a pilot-industrial installation was made, which is a model of a phase separator of size (LxBxH = 2.4x0.4x2.7), m. Samplers were provided that allow monitoring the quality of water treatment during each FSD compartment, in t .h. and installation height. The reagents used were Aqua-Aurat-30TM (AU) and MCAF.

The studies were carried out at the local treatment facilities (LTF) of the plant producing vegetable oils.

3 Results

During the treatment of fat-containing wastewater, the PDS was located in the LTF industrial building of the industrial enterprise. Wastewater was supplied from the receiving tank simultaneously to the existing grease traps and to the PDS with a flow rate of 0.55-0.95 m³/h.

The following PDS operation modes were investigated:

1. Wastewater supply without reagents, without aeration, the initial angle of inclination of thin-layer modules (TM) 60°.
2. The same according to p. 1 with a change in the angle of inclination of the TM to 50 и 55°.
3. The same according to p.1, with aeration.
4. The same according to p.3, with a change in the angle of TM, dose AC – 60 mg/l.
5. The same according to p.4, dose AC – 180 mg/l.
6. The same according to p.1, dose MCAF – 22 mg/l.

Operational control of the process was carried out visually along the “ring”, and the best samples for transparency and characteristic for the regime - analytically in an accredited laboratory.

Samples for analysis were taken from the upper (B) and lower (H) through the valves (Fig. 4) of the PDS aeration zone in order to determine the height of the treated wastewater for its supply to sedimentation, as well as at the outlet of the installation. The averaged indicators of the best cleaning efficiency IWW modes are presented in table 3 and in fig. 5.

Table 3. Indicators of preliminary treatment of fat-containing wastewater at the PDS.

Cleaning Technology, Sampling Point	Fats, mg/l	Suspended substances, mg/l	pH
Mode 4, top	179	516	7
Mode 4, bottom	228	778	7
Mode 4, average sample	284	432	7
Mode 3, exit	107	312	7

Mode 3, aeration, AC, exit	244	470	7
Mode 3, aeration, MCAF, exit	198	214	7

Note. Initial concentrations, mg/l: fats – 12560; suspended solids - 984, pH - 6.8.

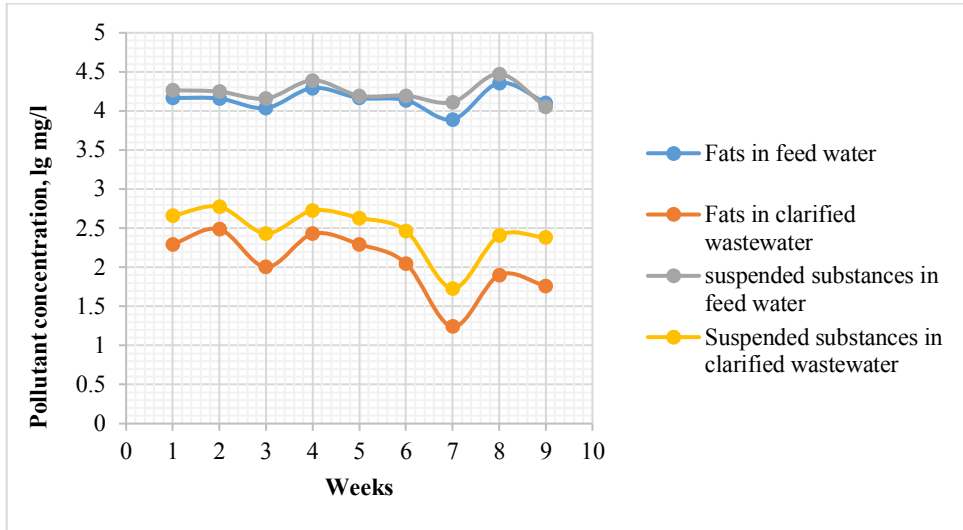

Fig. 5. Concentrations of pollutants entering and leaving wastewater from treatment facilities for the period 01.10.14-31.11.14 (averaged values over 9 weeks).

Note. Lg - logarithm of pollutant concentrations.

The research results show the high efficiency of the preliminary treatment of fat-containing wastewater at the PDS, as well as the need for in-depth water sampling.

4 Discussion

During the tests, the efficiency of coalescence of fats in a hydrophobic filter at the inlet of the installation was confirmed.

According to [8], quicklime with a dose of 500-1000 mg/l, in an amount of up to 20 tons per month depending on consumption, is used as a reagent for LTF IWW of vegetable oil production enterprises, depending on consumption, which increases the production costs of the enterprise for the purchase of reagents and waste disposal. To improve the quality of treated water to the levels established by regulatory documents and to reduce costs, retechnologization of treatment plants using the physicochemical scheme of wastewater treatment has been carried out.

To replace quicklime, it was proposed to use carbide sludge, which is a large-tonnage waste from the production of acetylene.

In laboratory conditions, a test coagulation of IWW with applied and replaceable reagents was performed: carbide sludge (KI), lime (CaO) and sludge from the water treatment plant of the thermal power plant. When conducting trial coagulation, the conditions of mixing hydrodynamics were ensured [16].

The advantage of KI over other reagents was revealed. Thus, it was proposed to use carbide sludge to replace quicklime.

X-ray phase analysis (Fig. 6) [17] showed that carbide sludge contains phases: calcium carbonates (CaCO_3) and magnesium (MgCO_3), which allows it to be used as a reagent instead of quicklime, and its lower cost (5 times) causes a reduction in costs [18-21].

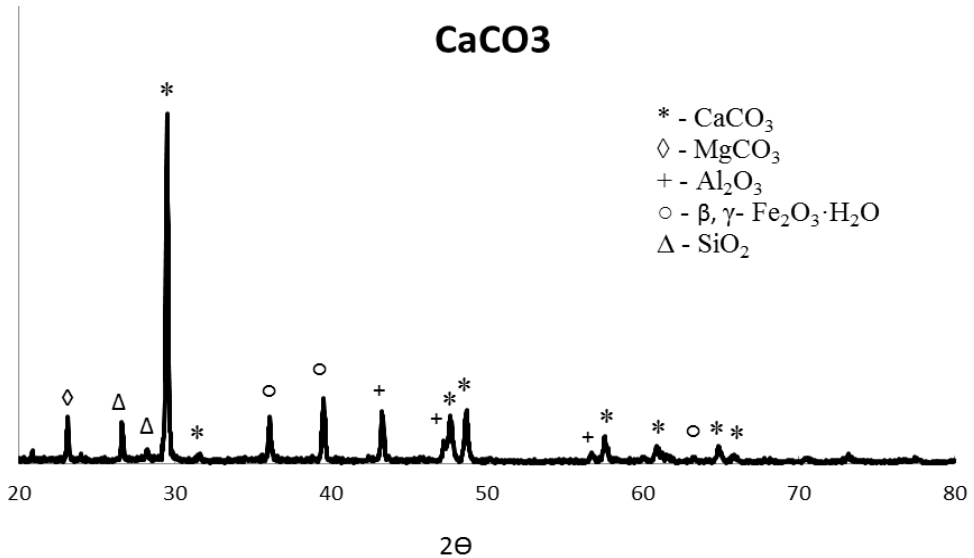

Fig. 6. X-ray of the reagent KI.

Trial coagulation was also carried out using aluminum-containing sludge, which is a large-tonnage waste that is formed during alkaline milling of aluminum structures and contains mainly sodium hydroaluminat (70-75%), pH about 13. with the main component (up to 50%) in the form of sodium hydroaluminat (SHA) [7].

It was found that the best purification is achieved with a SHA dose of 10 g / l, while the “ring” transparency is 5-6 cm and the sludge sediment layer height is 10 cm. In this case, the coagulation efficiency depends on the parameters of the initial waste fluid: carbonate alkalinity, pH, concentration of contaminants and their degree of dispersion.

To optimize the reagent wastewater treatment of a sunflower oil production company, a fractional factor experiment (FFE) of type 24-1 was carried out using a reagent carbide sludge.

The studies were carried out according to the test coagulation technique with “fast” and “slow” [7.15] mixing for 30 and 120 seconds and the subsequent 30-minute sedimentation. The fat content, the volume of the layer of settled sediment, and also the value of the hydrogen index were recorded. In this case, the initial wastewater had the following indicators: pH = 6.8, sludge layer height - 0.2 cm, fat - 2.5 g/l.

The optimization parameters were:

Y_1 — the effectiveness of wastewater treatment from fats:

$$Y_1 = (C^{\text{source}} - C^{\text{pur}}) * 100 / C^{\text{source}}, \% \quad (1)$$

where C^{source} и C^{pur} – the concentration of fat in the source and treated wastewater, respectively, mg / l;

Y_2 — pH increase during cleaning:

$$Y_2 = \text{pH}^{\text{pur}} - \text{pH}^{\text{source}}, \quad (2)$$

where $\text{pH}^{\text{source}}$ и pH^{pur} – the pH value of the source and treated wastewater, respectively.

Y_3 — increase in the volume of sludge, cm^3 :

$$Y_3 = S^{\text{pur}} - S^{\text{source}} \quad (3)$$

where SI^{source} и SI^{pur} – sludge volume in the source and treated wastewater, respectively, cm^3 .

Factors and levels of variation are given in table. 4.

Table 4. Factors and levels of variation of FFE type 2^{3-1} .

Factors		Levels of variation			Range of variation
		-	0	+	
X_1	Dose of reagent (D), g/l	1	8	15	7
X_2	Rapid mixing (M_R), sec.	30	75	120	45
X_3	Slow mixing (M_S), sec.	60	150	240	90

In accordance with the strategy of an active experiment in laboratory conditions on real IWW of a plant for the production of sunflower oil, a FFE of type 23-1 with two replicates was implemented (Table 5-9) and its regression processing was carried out [10].

The obtained experimental data according to the Cochren criterion are equal (at $p = 0.05$), and the interpolation equations (4-6) of the process for calculating the efficiency of IWW purification are adequate according to the Fisher criterion.

$$Y_{calc}^F = 67.13 + 22.23 X_1 + 1.98 X_2 - 1.98 X_3, \% \quad (4)$$

$$Y_{calc}^{pH} = 1.15 + 0.575 X_1, \text{ un. pH} \quad (5)$$

$$Y_{calc}^{SI} = 39.03 + 18.8 X_1, \text{ cm}^3. \quad (6)$$

The transition from coded to natural factors was carried out [13], and the following equations for the efficiency of IWW purification were obtained:

- for fats

$$E_F = 35.12 + 0.044 M_R + 0.044 M_S + 3.18 D, \% \quad (7)$$

- for pH

$$E_{pH} = 0.49 + 0.082 D, \text{ un.pH} \quad (8)$$

- by volume of sludge

$$E_{SI} = 17.54 + 2.69 D, \text{ cm}^3 \quad (9)$$

Using the obtained equations (7-9), we plotted graphs of the dependence of the cleaning efficiency (%) of IWW, pH, reduction of the volume of sludge on the dose of the reagent (CI), g/l, at fast (30 s) and slow (120s) stirring (Fig. 7 a, b, c).

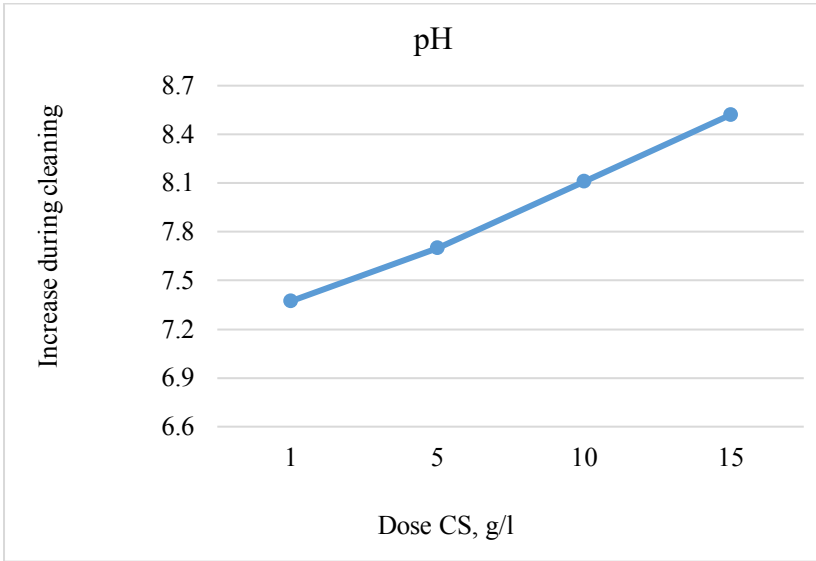

Fig. 7a. Graph of the dependence of pH on the dose of the reagent (Cl).

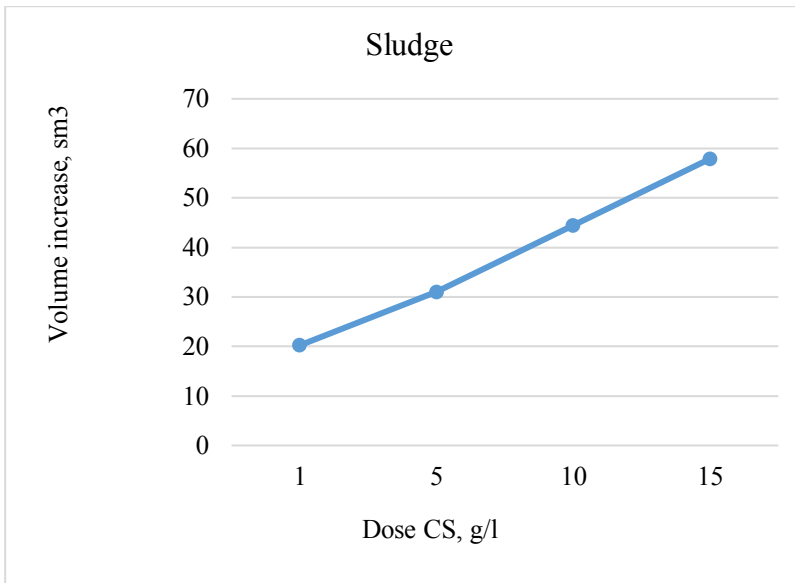

Fig. 7b. Graph of the dependence of the reduction of the volume of sludge on the dose of the reagent (Cl).

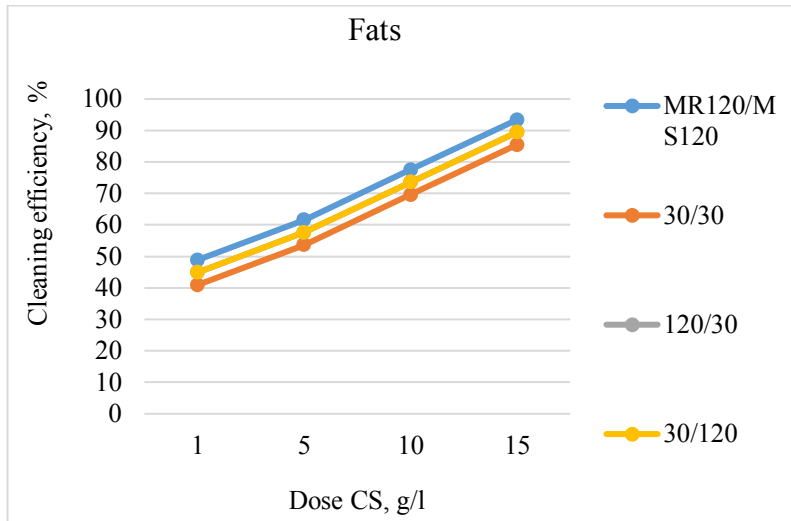

Fig. 7c. Graph of the dependence of the cleaning efficiency (%) of IWW on the dose of the reagent (CI) at fast (30 s) and slow (120s) stirring.

Note. The transparency of the wastewater treated with CS reagent, visually determined by the “ring” method, in the studies performed ranges from 9 to 9.7 cm.

In industrial conditions, IWW carried out pilot industrial cleaning of IWW using CS and SHA as reagents (table 5).

Table 5. Indicators of pilot industrial treatment of fat-containing wastewater at the PDS using CS + SHA.

№	pH		Fats, mg/l		E,%	Suspended substances, mg/l		E,%
	entrance	exit	entrance	exit		entrance	exit	
1	7.9	7.5	851	28	97	1283	64	95
2	8.0	9.1	15704*	982	94	23106*	4410	81
3	7.4	8.0	11310*	211	98	163126*	592	99
4	7.9	8.0	645	33	95	916	78	91
5	8.0	7.1	873	204	77	1063*	644	39
medium	-	-	5876.6	291.6	95	37898.8	1157.6	97

* The equipment was cleaned from technological mixtures

5 Conclusions

1. The results of pilot tests have shown the effectiveness of the use of carbide sludge (both in terms of the quality of treated water and the cost of the enterprise for the purchase of reagents) and the reliability of the equations obtained. Currently, the dose of carbide sludge in wastewater treatment plants is 18-20 g/l.

2. Assessing the results of the efficiency of the phase separator during the preliminary cleaning of IWW contaminated with fats, we can conclude that this apparatus can be recommended as a unit for preliminary separation of dispersed liquid and solid impurities.

References

1. Yu.M. Meshengisser, *Retekhnologizatsiya sooruzheniy ochistki stochnykh vod.* (OOO «Izdatelskiy dom «Vokrug tsveta», Moscow, 2012)
2. T. Ahmed, N. Makwashi, M. Hameed, A Review of Gravity Three-Phase Separators **8(3)**, 143-153 (2017) ISSN: 2141-7016
3. I. Husain, M. Alkhatib, M. Jammi, M. Mirghani, Z. Zainudin, A. Hoda, Problems, Control, and Treatment of Fat, Oil, and Grease (FOG): a Review **63(8)**, 747-752 (2014) DOI: 10.5650/jos.ess13182
4. D. Qian, D. Chen, N. Li, Q. Xu, H. Li, J. He, J. Lu, Journal of membrane science **554**, 16-25 (2018) DOI: 10.1016/j.memsci.2017.12.084
5. P. Cisterna, Environments **4**, 69 (2017) DOI: 10.3390/environments4040069
6. S. Noamani, S. Niroomand, M. Rastgar, Clean Water **20** (2019) DOI: 10.1038/s41545-019-0044-z
7. V.S. Machigin, *Ochistka zhirosoderzhashchikh stochnykh vod metodami ultrafiltratsii i ognevoغو obezvrezhivaniya: avtoref. Dis.* (Saint-Petersburg, 2006)
8. V.I. Kichigin, *Vodootvodyashchiye sistemy promyshlennykh predpriyatiy: uch. posobiye* (Izdatelstvo ASV, Moscow, 2011)
9. E. Bayan, T. Lupeiko, M. Gorbunova, E. Tolstobrova, Russian Journal of Applied Chemistry **88(7)**, 1728-1732 (2015) DOI: org/10.1134/S1070427215100274
10. L.A. Kulskiy, *Proyektirovaniye i raschet ochistnykh sooruzheniy vodoprovodov* (Budivelnik, Kiyev, 1972)
11. A. Demirbas, H. Bamufleh, G. and W. Alalayah, Treatment of contaminated wastewater **35**, 883–889 (2017) DOI: 10.1080/10916466.2017.1290653
12. E. Mysara, A. Masoud, Influence of flow characteristics on the design of twophase horizontal separators **15(2)** (2014)
13. J.J. Ronan, K.A. Perrotta, P.E. Rebe, *Pat. 6066264, U.S. Method of Oil-Water Separation* (2000)
14. V.G. Ponomarev, *Ochistka proizvodstvennykh stochnykh vod ot grubodispersirovannykh primesey* (Moscow, 1993)
15. B.N. Frog, *Ekologo-khimicheskiye aspekty protsessov vodoочistki na predpriyatiyakh lesopromyshlennogo kompleksa* (Moscow, 2002)
16. D. Butko, E. Vilson, E. Yakovleva, OALib Journal **40(4)**, 385-394 (2018) DOI: 10.1051/mateconf/201710607003
17. R. Wongnoi, W. Songkasiri, Ch. Phalakornkule, OALib Journal **79(2)**, 199-207 (2007) DOI: 10.2175/106143006X111790
18. A. Smolyanichenko, Ah. Khalil, OALib Journal **698** (2019) DOI:10.1088/1757-899X/698/2/022072
19. G. Bru, P. Klimov, A. Smolyanichenko, OALib Journal **931**, 966–969 (2018) DOI: 10.4028/www.scientific.net/MSF.931.974
20. Ah. Khalil, A. Smolyanichenko, E. Vilson, E. Shchutskaya, E. Tsurikova, OALib Journal **1**, 212–218 (2019) DOI: 10.2991/isees-19.2019.42
21. A. Yasar, N. Ahmad, M. Chaudhry, Aa. Ali Khan, OALib Journal **19(5)**, 553-558 (2007) DOI: 10.1016/S1001-0742(07)60092-8