

Comparative analysis of strength and deformation of reinforced concrete and steel fiber concrete slabs

Mykola Surianinov*, Stepan Neutov, and Iryna Korneieva

Odesa State Academy of Civil Engineering and Architecture, Odesa, 65029, Ukraine

Abstract. The results of experimental studies of the steel fiber influence on the bearing capacity, deformability and crack resistance of reinforced concrete multi-hollow plates are given. We investigated a serial floor slab and a similar one, but with the addition of steel fiber. Both plates are factory-made. For testing, the testing apparatus was designed and manufactured that made it possible to study full-size floor slabs in laboratory conditions. The tests were carried out according to a single-span scheme with the replacing equivalent load. The loading was carried out by applying two concentrated strip vertical loads along the plate width. The load was applied in steps of $(0.04 \div 0.05)$ from the breaking load. Each stage ended with exposure lasting up to 10 minutes with fixing all the necessary parameters. Deformations were measured using dial gauges. From the moment the first crack appeared in the stretched zone of concrete, the process of crack formation and opening was monitored. At each level, using the Brunell tube, the width of their opening and height were measured. The moment of cracking in both slabs began at the same relative strain. It has been established that the bearing capacity and crack resistance of a slab of combined reinforcement using steel fiber are respectively 50 and 44% higher than that of a similar reinforced concrete slab. The maximum deflection of the slab of combined reinforcement is 37.5% lower than that of conventional reinforced concrete. The destruction of both slabs occurred under loads, when the relative deformations in the compressed zone of concrete reached 0.80×10^{-3} and 1.10×10^{-3} for reinforced concrete and steel-fiber concrete slabs, respectively, the difference is 37.5%.

1 Introduction

Hollow core slabs are usually used as slabs between floors in the construction of buildings and structures. Of various shapes and sizes, with different bearing patterns, they are all widely used in construction. Their production accounts for a significant mass part of reinforced concrete of the total material consumption during the construction of the facility. This type of product can be called universal, because its use is not limited to the type of structure. The main distinguishing feature of such floor slabs is the presence of voids located along the slab. These voids almost always have a circular cross section. Also, characteristic is the manufacture of recessed grooves along the side faces. Such plates are pre-stressed and non-stressed by pouring into molds and subsequent vibration compaction with final heat treatment.

The improvement of such demanded reinforced concrete structures, the increase in their bearing capacity, crack resistance and durability is an actual problem.

2 Recent researches analysis

It is known that the use of steel fiber leads to an increase in the physicomechanical characteristics of concrete, namely, strength, deformability, crack resistance, water

permeability, impact strength, frost resistance, etc. [1-3].

Most of these characteristics are usually determined in the laboratory. In this case, the main objects of research are samples in the form of cubes or prisms, and less often – models in the form of beams or slabs of reduced size.

Over the past five years, the authors have carried out large-scale studies to determine the effect of steel fiber on the strength and deformation properties of fiber concrete [4, 5]. It was found that the strength and crack resistance of steel fiber concrete, higher than that of ordinary concrete, on average, by 40 and 30%, respectively. Creep – on the contrary, is (20-22)% lower. The long-term strength of steel fiber-reinforced concrete beams that have been exposed to operational loads for more than 400 days is on average 37% higher than that of similar beams made of ordinary concrete. All these results were obtained, again, in laboratory conditions, and, as it is known, they are far from always confirmed by the operation of real structures.

Studies to expand the scope of steel fiber concrete are carried out by many authors [6-8]. So, in [9], the use of fiber-reinforced concrete slabs is considered, which are more economically and technically profitable compared to conventional reinforced concrete slabs when installing floors. The author substantiates this by an increase in impact strength and ductility, higher crack resistance and bearing capacity. An interesting comparison of the

* Corresponding author: sng@ogasa.org.ua

properties of concrete slabs with two types of fiber fibers and in the absence of fiber reinforcement was presented in [10]. Four specimens contained steel and polypropylene fibers added in a volume ratio of 0.5% and 1.0%. The slabs had dimensions of $820 \times 820 \times 80$ mm and were supported by four rollers along the edges that control the displacement. The concentrated load is applied in the center of the plate. The results of experimental studies were compared with theoretical predictions. Based on the processing of the data obtained, it was concluded that 1% of steel fibers by volume has the best effect on the operation of the slabs. This conclusion coincides with our results regarding the effectiveness of fiber reinforcement.

A. Blanco [11] believes that combining fibers with traditional reinforcement can be a very interesting design decision to create more durable and economical designs. His work is devoted to the analysis of the bearing capacity and ultimate state of slabs. For this purpose, eighteen concrete slabs ($3 \times 1 \times 0.2$ m) with different reinforcement, fiber types (steel and plastic) and their volumetric content (0.25 and 0.50%) were investigated. These slabs were tested for bending with data monitoring at four points.

The works of other authors can be noted [13-14], but nevertheless, the influence of steel fiber on the work of flexible concrete elements has not been fully studied, and many aspects of practical interest remain.

3 The purpose of work

The aim of this work is an experimental study of the influence of steel fiber on the bearing capacity, deformability and crack resistance of serial reinforced concrete multi-hollow slabs manufactured in the factory.

4 Materials and methods

The object of the study are floor slabs PK 30.12-8, manufactured in the factory by the enterprise Velikodolinsky ZhBK Plant, LLC in accordance with regulatory documents [15, 16] and working drawings of the 1.141-1 series [17], using conventional technology and with the addition of steel fiber with curved ends.

For testing, a testing apparatus was designed and manufactured that made it possible to study full-sized floor slabs in laboratory conditions (Fig. 1). In order to comply with safety regulations and prevent brittle collapse of reinforced concrete slabs during the test under load, steel pipes were freely threaded into the extreme voids, which did not impede the deformation of the structure. This made it possible to timely detect the appearance of cracks, safely measure their parameters and draw on the underside of the slab.



Fig. 1. Testing apparatus.

To determine the strength properties of concrete, at the factory, samples of cubes with a rib size of 10 cm were made from the same mixture as the slab, which were tested for compression in laboratory conditions. The obtained value of cubic strength showed that concrete corresponds to grade C16/20. Determination of concrete strength during short-term loading was carried out in accordance with the requirements of current standards [18, 19].

The tests were carried out according to a single-span design with a substitute equivalent load (Fig. 2). The loading was carried out by applying two concentrated strip vertical loads along the slab width.

5 Research results

Two multi-hollow floor slabs were tested, one is ordinary reinforced concrete (PK series 30.12-8), and the second is similar, but with the addition of 1% steel fiber. Slabs have dimensions in the plan of 1190×2980 and a height of 220 mm (Fig. 3), concrete consumption 0.43 m^3 .

During the tests, the load applied to the element and the corresponding deformations were recorded; tests were carried out in accordance with [20].

The load was applied in steps of $(0.04 \div 0.05)$ from the breaking load. Each stage ended with exposure lasting up

to 10 minutes with fixing all the necessary parameters. Deformations were measured using dial gauges with a division price of 0.001 mm and a base of 25 cm. Five gauges (3, 4, 5, 6, and 7) were installed on the upper surfaces of the slabs, in the central part (Fig. 3). Gauges 1, 2 and 8, 9 were fixed to the side surfaces (faces) of the plates. The first two gauges were located in the middle of the span in the zone of clean bending, and a pair of indicators 8, 9 in the zone of load transfer (Fig. 3). The first and ninth gauges are in the stretched zone of concrete, 2 and 8 are in the compressed.

From the results shown in Fig. 4 and 5, it follows that the readings of all 5 gauges located on the upper surfaces

of the slabs from the beginning of loading and up to failure change equally synchronously and almost by the same value. The latter indicates that the loading of reinforced concrete slabs using a two-level cross-beam system ensures uniform loading of its upper surface.

From the moment the first crack appeared in the stretched zone of concrete, the process of crack formation and opening was monitored. At each level, using the Brunell tube, the width of their opening and height were measured.

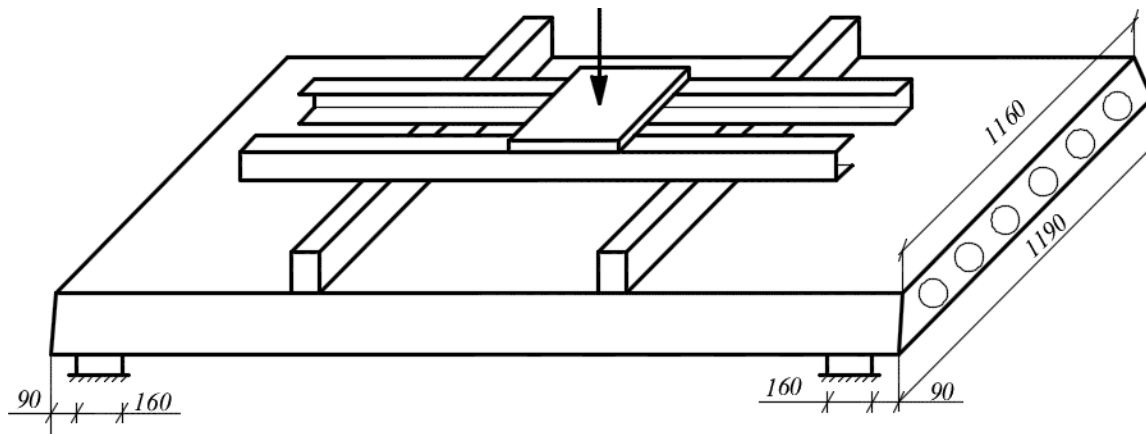

Fig. 2. Loading concept.

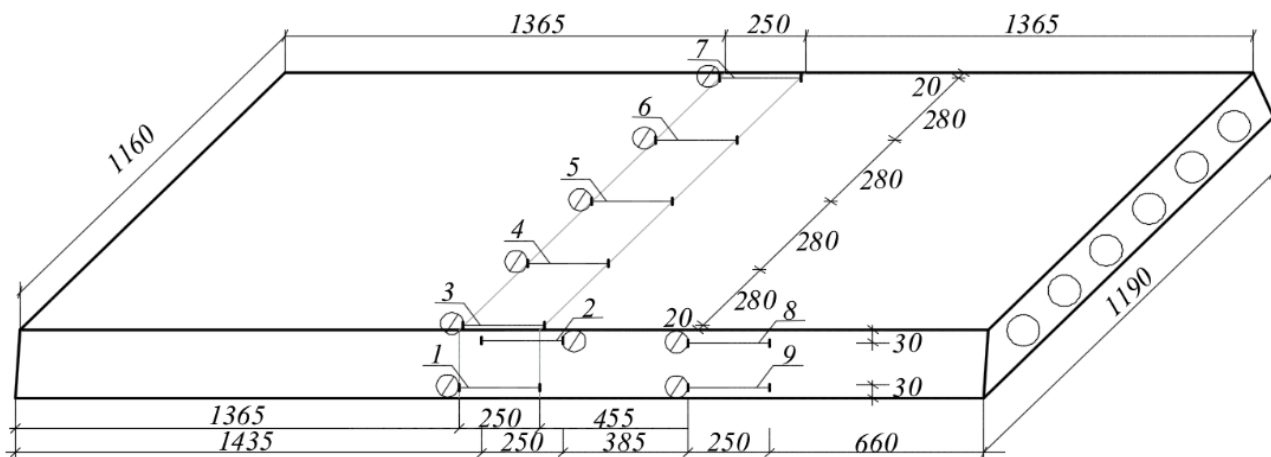

Fig. 3. Indicator layout.

Fig. 4 shows the nature of the deformations obtained in the process of loading a reinforced concrete floor slab. From the results shown in the figure, it can be seen that three sections can be distinguished on the deformation curves.

I section. Up to a load level of 44.41 kN, corresponding to the beginning of crack formation, a linear relationship is observed for all concrete fibers. The values of relative deformations in the compressed and stretched zones are almost the same ($\epsilon = 0.1 \times 10^{-3}$).

II section. At VIII-X loading steps, when the load varies in the range from 44.41 kN to 59.21 kN, a sharp change in the strain growth rate occurs (the angle of

inclination of the curves changes significantly). Deformations in the compressed and stretched zones of concrete increase almost 3 times. Such a significant increase in deformation is explained by the avalanche-like process of cracking (12 cracks with an opening width of up to 0.005 mm).

In section III, with a load of more than 59.21 kN, the relative deformations in the compressed zone of concrete again change almost linearly up to the breaking load (108.55 kN) and amount to 0.75×10^{-3} . In the stretched zone of concrete, the strain growth rate is significantly higher. Deformations from 0.2×10^{-3} increased to 1.4×10^{-3} , 2 times higher than the deformation of the compressed

zone of concrete. This is explained by the fact that, at this stage of loading, along with the formation of new cracks, the process of opening previously formed cracks is

intensified. The width of their disclosure increases 3-4 times.

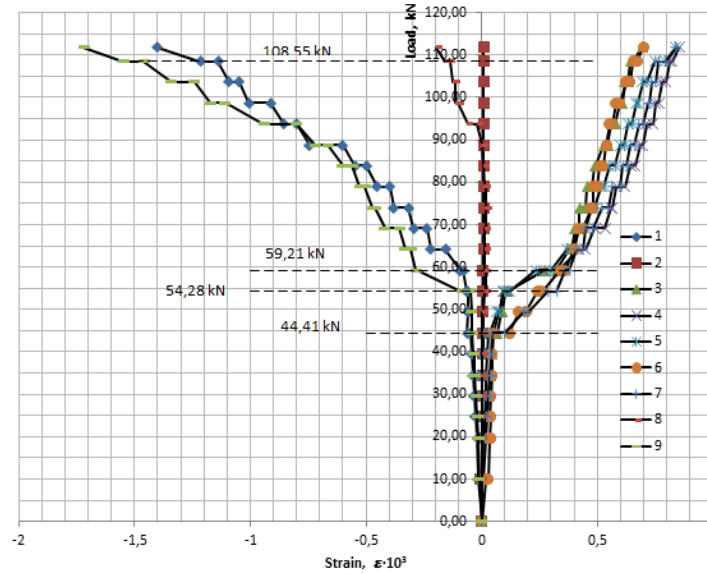

Fig. 4. Deformation of a hollow-core reinforced concrete slab according to indicators.

Figure 5 shows the deformation of concrete fibers in a steel-fiber concrete slab.

The nature of the curves shown in Fig. 5 is similar to the nature of the strain curves of concrete fibers in a conventional reinforced concrete slab (Fig. 4). Namely, a linear relationship is observed up to the load level corresponding to the onset of crack formation (64.14 kN). Relative deformations corresponding to the indicated load do not exceed the value of 0.1×10^{-3} .

The latter indicates that the cracking moment in both slabs begins at the same relative strain equal to 0.1×10^{-3} .

At the second stage, in the range of load changes from 64.14 kN to 78.95 kN, the relative deformations in the compressed zone of concrete increase to 0.2×10^{-3} , which is two times lower than in a slab of ordinary reinforced concrete. This is explained by the fact that 12 cracks

formed in an ordinary slab at this stage, and in a slab of steel-fiber-reinforced concrete – 7. Moreover, not only the number of cracks, but also the width of their opening is 1.7 times smaller.

In the third section, at loads greater than 78.95 kN, the relative deformations in the compressed zone of concrete again change linearly up to a breaking load of 162.83 kN.

Comparing the results shown in Fig. 4 and 5, it is easy to verify that the destruction of the investigated plates occurred when the relative deformations in the compressed zone of concrete reached 0.80×10^{-3} and 1.10×10^{-3} for reinforced concrete and steel-fiber concrete plates, respectively; the difference is 37.5%.

In a reinforced concrete slab, this deformation occurs at a load of 108.55 kN, and in a steel-fiber concrete slab at 162.83 kN; these values differ by 50%.

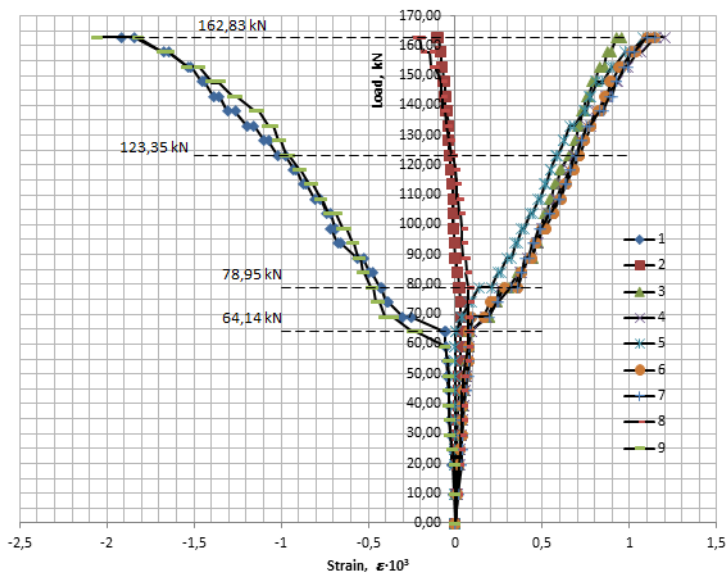

Fig. 5. Deformation of a hollow-core steel fiber concrete slab according to indicators.

Figure 6 shows the nature of the changes in the deflection of a reinforced concrete slab during its loading. Deflections were measured using the Maximov deflections with a division value of 0.01 mm. The results presented in Fig. 6 are identical to the results shown in Fig. 4, in the sense that the previously described stages of structural deformation are clearly traced on the curves.

Stage I to the load level of 44.41 kN (41% of the destructive) – linear. The maximum deflection at the end of the stage is 1.7 mm, i.e. 7% of its maximum value at the destruction moment.

At stage II, the linearity is substantially violated, and by the end of the stage, the deflections increase to 5.5 mm, i.e. more than 3 times with an increase in load of only 10%. This is also explained by the fact that 12 cracks formed in the plate at this stage.

At stage III, the load compared to the first two stages doubled, and the deflections increased five times to a value of 2.5 cm.

In Figure 7 shows the nature of the change in deflections in a steel-fiber concrete slab during its loading. In this figure, as in the previous ones, 3 sections can be distinguished. The first one is linear up to the load level corresponding to the moment of crack formation (64.14 kN).

At the second section, in the load interval from 64.14 kN to 123.35 kN, linearity is broken, because 19 cracks with an opening width not exceeding 0.005 mm are formed.

In the third section, the load varies from 123.35 kN to 162.83 kN. The process of formation of new cracks is significantly slowed down (5 new cracks), and in parallel with it, the process of intensive opening of existing cracks begins. The width of the opening of five cracks increased 10 times (0.05 mm).

Figure 8 shows for comparison the deflections in reinforced concrete and steel fiber concrete slabs. From the presented results it is seen that the maximum deflection in a steel-fiber concrete slab is 37.5% less than in a similar reinforced concrete slab.

This is explained by the fact that at the time of fracture in a conventional reinforced concrete slab there were 8 through cracks with an opening width of up to 0.1 mm, while in a steel fiber reinforced concrete slab there were only 4 with an opening width not exceeding 0.06 mm. In addition, the total magnitude of the opening of all cracks in an ordinary slab is 1.57 mm, and in steel-fiber concrete – only 0.52 mm, i.e., almost 3 times less.

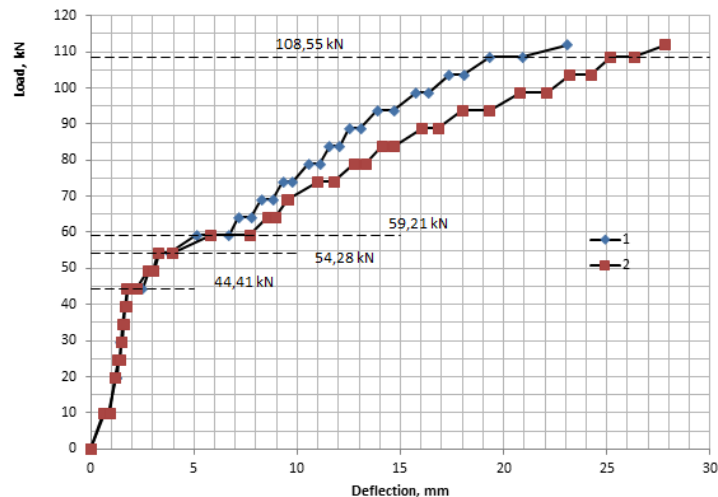

Fig. 6. Deflection of a reinforced concrete slab in the center of the span according to the readings of two deflection meters.

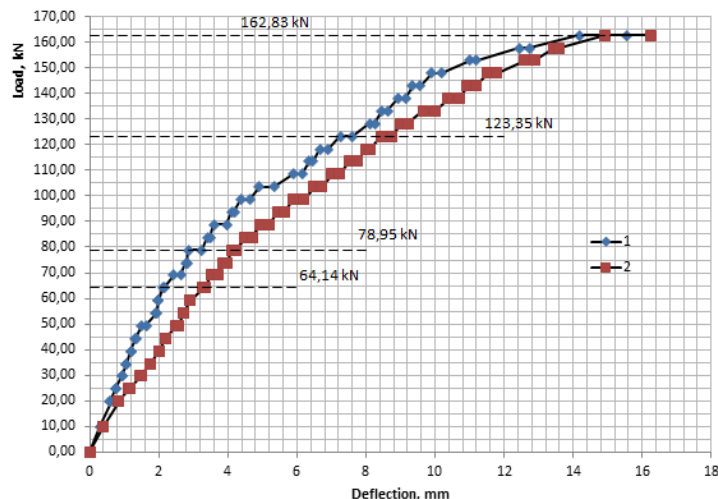

Fig. 7. Deflection of a steel fiber concrete slab in the center of the span according to the readings of two deflection meters.

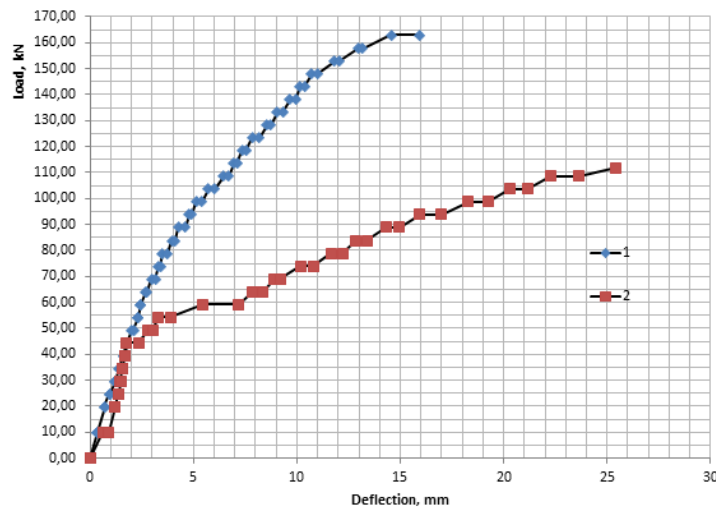

Fig. 8. Deflections of hollow-core slabs in the center of the span 1 – steel fiber concrete slab, 2 – reinforced concrete slab.

Along with indicators, strain gauges with a strain measurement base of 50 mm were glued on the upper and lateral surfaces of reinforced concrete and steel fiber reinforced concrete slabs (Fig. 9). The results presented in Fig. 10, indicate that two completely unrelated strain measurement systems show very close values (the difference does not exceed 5%).



Fig. 9. The location of the strain gauges under the indicator.

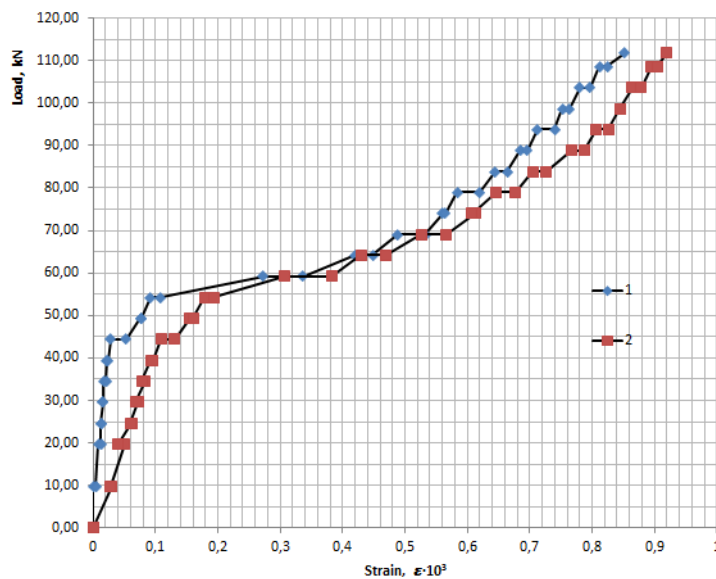

Fig. 10. The deformation of the longitudinal fibers of the upper side of the plate according to the indications of the indicator and strain gauge: 1 – according to the indications of the indicator, 2 – according to the indications of the strain gauge.

6 Conclusions

An analysis of the experimental studies showed that the main parameters that determine the physicomaterial characteristics of concrete and fiber-reinforced concrete, namely, bearing capacity, deformability and crack resistance, are interconnected throughout all stages of loading.

1. The bearing capacity and crack resistance of a slab of combined reinforcement using steel fiber are respectively

50 and 44% higher than that of a similar reinforced concrete slab.

2. The maximum deflection of the slab of combined reinforcement is 37.5% lower than that of ordinary reinforced concrete.

3. The destruction of both slabs occurred under loads, when the relative deformations in the compressed zone of concrete reached $0.80 \cdot 10^{-3}$ and $1.10 \cdot 10^{-3}$ for reinforced concrete and steel-fiber concrete slabs, respectively, the difference is 37.5%.

References

1. N.P. Bleshik, I.V. Koval, *Probl. sovr. bet. i zhb.* 2, 80–113 (2011)
2. V.I. Pavlenko, V.B. Aronchik, *Svoystva fibrobetona i perspektivy ego primeneniya: analiticheskij obzor* (1978), p. 57
3. S.P. Neutov, I.B. Korneyeva. *Vis. ODABA* 76, 63–70 (2019)
4. S.P. Neutov, M.M. Sidorchuk, M.G. Surianinov, *Teh. N.* 60, 181–186 (2017)
5. M.G. Surianinov, S.F. Neutov, M.M. Vygnanec, in *Tezi dopovidej 75-yi naukovo-tehnichnoyi konferenciyi profesorsko-vkladackogo skladu akademiyi*, Odesa (2019), p. 20
6. D.E. Kapustin, Dissertation, 2015
7. D.A. Smirnov, Dissertation, 2011
8. K.V. Talantova, Dissertation, 2013
9. W. Labib, N. Eden, *L3 3AF*, 466–477
10. N.S. Muhammad, M.N. Hadi (Francis and Taylor, London, 2008), pp. 407–412
11. P. Pujadas, A. Blanco, A. De la Fuente, A. Aguado, *Cracking Behavior of FRC Slabs with Traditional Reinforcement* (2011). doi:10.1617/s11527-011-9791-0
12. R.F. Fardiev, A.H. Ashrapov, A.I. Mustafin. *Izv. KGASU* 4 (30), 72–77 (2014)
13. M.Abramski, A. Albert, R. Pfeffer, J. Schnel, *Beton- und Stahlbetonbau* **105**, 349–361 (2010)
14. M. di Prisco, A. Pourzarabi, M. Colombo, Department of Civil and Environmental Engineering Politecnico di Milano MilanItaly (2018)
15. DSTU B V.2-6-53:2008. *Pliti perekrittiv zalizobetonni bagatopustotni dlya budivel i sporud* (2008)
16. DSTU B V.2.6-2:2009 *Konstrukciyi budinkiv i sporud. Virobi betonni i zalizobetonni. Zagalni tehnicni umovi* (2010)
17. Seriya 1.141-1. *Paneli perekrytij zhelezobetonnye mnogopustotnye. Rabochie chertezhi: cNiEP Zhilisha*. NIIZhB 60, 52 (1983)
18. DSTU B.V.2.7-214:2009 *Betoni. Metodi viznachennya micnosti za kontrolnimi zrazkami* (2010)
19. BS EN 12390-3:2009 *Testing hardened concrete – Part 3: Compressive strength of test specimens*. (2009)
20. DSTU B V.2.6-7-95 (GOST 8829-94). *Izdeliya stroitelnye betonnye i zhelezobetonnye sbornye. Metody ispytanij nagruzheniem. Pravila ocenki prochnosti, zhestkosti i treshinostjivosti*, Part IV (1997)