

# Adoption of Multilevel Inverter based Dynamic Voltage Restorer for Power Quality Improvement with Adjustable DC-Link

Kummari Geethika<sup>1,\*</sup>, Vinay Kumar Awaar<sup>2</sup>, and Praveen Jugga<sup>3</sup>

<sup>1</sup>PG Student, Power Systems, GRIET, Hyderabad, India

<sup>2</sup>Associate Professor, EEE Dept., GRIET, Hyderabad, India

<sup>3</sup>Professor, EEE Dept., GRIET, Hyderabad, India

**Abstract.** Dynamic Voltage Restorer (DVR) is a method of overcoming voltage sag and swell in electrical power distribution. To boost up voltage levels on load side on power disturbances DVR can be used so as the equipment connected will have good voltage profile. In this Pulse Width Modulation inverter is in solid-state electronic switching device were employed along with Integrated Gate Bipolar Transistor by the DVR, the alternating current voltage is controllable at real and reactive powers which are made independently. The MLI; is organized as the cascaded H-bridge inverter units. The function of Multilevel Inverter; is to arrange the voltages from a significant direct current source. Here in the DVR, there is no need for external output filters. In the planned DVR, a dc-dc converter is combined with an MLI. By considering the voltage sag magnitude of a dc-dc converter can regulate the dc-link voltage. Hence the output voltage of the multilevel inverter; always has a last number of levels. Instead of using the PWM based technique, the fundamental frequency method can be used in the multilevel inverter. The proposed DVR operation range of mathematical analysis is specified in detail. The simulation results are prepared by using Simulink/MATLAB.

## 1 Introduction

Voltage variations are unsafe for all electronic devices, computers, and automated systems. These voltage variations consist of different types of events, which are short term and long term events. In these short term events, there are more problems and from those problems the most damaging event in power systems in voltage sags. IEEE standard defines power quality as "The concept of powering and grounding sensitive electronic equipment in a manner suitable for the equipment." The voltage sags are the most expensive and economically most damaging events in many power distribution systems [1]. For compensating voltage disturbances, many solutions are available [2-4]. The two most essential problems in power quality are voltage sag and voltage swell that produced almost 50% of the distribution system power quality problems. There are different types of compensation of voltage sags that have been used, but here only one method is used that is DVR with energy storage can be used to control power quality problems [5]. For the safe operation of the loads, the voltage on the sensitive load, which remains almost unchanged, has been provided in [6]. Voltage sag is an event where the line RMS voltage reduces from the nominal line voltage for a short period. To control the voltage sags, then we have to satisfy them. There are

many suitable solutions for voltage disturbances like DVR [7]. It is a well-organized solution for voltage disturbances. The voltage source inverter (VSI) is connected to the DVR in series with a series injection transformer (SIJ) during voltage sag [8]. Generally, through an injection transformer, the voltage source inverter generates compensation voltage, which is added to the grid voltage. The DVR operation based on the cascaded H-bridge multilevel inverter (CHB) multilevel inverter has minimum power, from the control method point of view, and it has been studied in [9]. DVR is to insert a voltage of the magnitude and frequency required to replace the load side voltage to choose amplitude and waveforms when the source voltage is uneven. The cascaded multilevel inverter based on the modified DVR, has been studied in [10]. The DVR circuit has alternative topologies with various topologies of VSI. It adopts the multilevel inverter in the DVR. By talking about the control methods of the uncomplicated model of an inverter is in the DVR design. The fundamental frequency method is used to compensate for the CHB with established voltage sag is presented in [11]. In the DVR structure, apart from the cascaded multilevel inverter topologies, the other multilevel inverters are neutral point clamped multilevel inverter and flying capacitor multilevel inverter have also been used [12-14]. In some output, voltage quality is not adequate

\* Corresponding author: [vinaykumaar.a@gmail.com](mailto:vinaykumaar.a@gmail.com)

because the output voltage is stepped voltage. CHB inverter is composed of a PWM as an operation of DVR is considered in [15]. The non-conventional topologies of multilevel inverter have been used in the DVR structure [16-17]. Here there are two types of topologies like symmetric and asymmetric topologies. The dc voltage source is connected to each of the H-bridge in the CHB multilevel inverter only; one dc voltage source is required. The minimum power performance of CHB multilevel inverter is built-in DVR considered in [18].

The thyristor controlled reactor is connected to DVR to reduce the energy storage size. The DVR build CHB multilevel inverter is controlled by discontinuous space vector modulation (SVM). Dominant power electronic converters in VSI are located in the DVR. In DVR, the energy storage is ignored to reduce the size, but the application to prevent the voltage sag in deep will be effective. The output voltage of the multilevel inverters rests on the depth of the voltage sag. The output voltage magnitude will be enormous in broad voltage sag and depressed in hallow voltage sag.

DC-link voltage can be maintained constant by building the number of voltage levels on the voltage sag depth. For depressed voltage sag, the multilevel inverter; is abused appropriately. For hallow voltage sags, the multilevel inverter; is more ineffective.

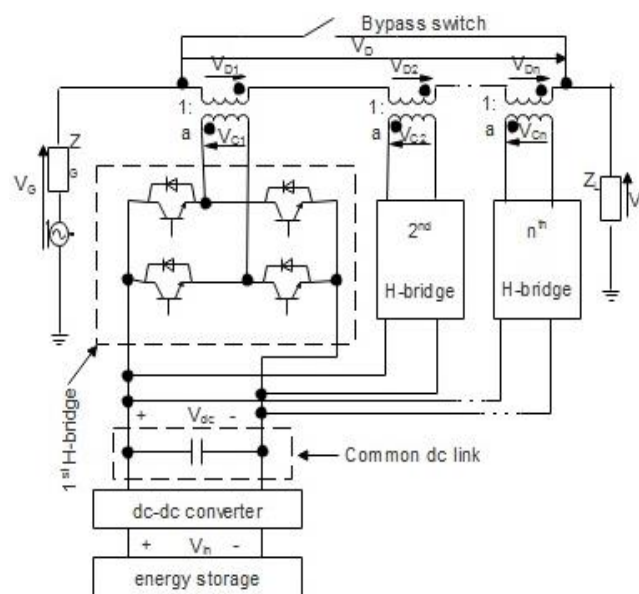
In this paper, a new strategy is suggested for multilevel inverter based DVR to improve the results for a multilevel inverter. To develop the dc-link voltage for the depth of voltage sag, the dc-dc converter is applied. By applying this process, an extremely convenient number of output voltage levels are developed for an immense diversity of voltage sag depth. To get the simulation results denoted the planned DVR.

## 2 Proposed DVR

The designed multilevel inverter; based on DVR denotes in fig 1. In this topology, the voltage sag depth is recognized to regulate the dc-link voltage. The dc output voltage ( $V_i$ ) is constant for energy storage, and this voltage is utilized as the input voltage to the dc-dc converter. The function of the dc-dc converter regulates the dc-link voltage ( $V_d$ ) permit to the voltage sags depth. The value of  $V_d$  is to overcome when the voltage sag has reduced depth, and the value of  $V_d$  denotes maximized when the voltage sags have great depth. The bringing up voltage of a multilevel inverter is regularly high so, it conducts the maximum modulation index nevertheless of the voltage sag depth. While voltage sag output, voltage levels are developed within an extensive range [19]. During balanced conditions with small energy storage, the capacitor proposes in the converter is to absorb the harmonic ripples. Here, many practical loads are of the inductive type with an inherence property of low pass filter.

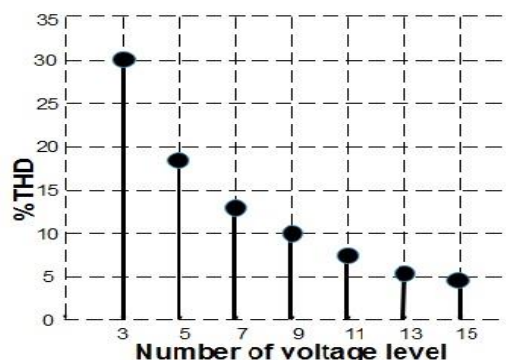
When the levels are the built-in multilevel inverter, then the quality of voltage insistence rises. As shown in fig (2), the low-frequency transformer is used at each H-bridge in DVR. By this, the cost command is high. Even when the operational voltage is minimum, the inverter; will operate at a minimum voltage where the transformer could extend the voltage. The other topology is like; the high-frequency transformer is recycled with a low-frequency transformer. It is presented in figure (2).

The dc-dc converter is attached to the energy storage, which gets the dc output voltage in this topology. Corresponding to the voltage sags, the dc-dc converter will modify its output voltage.

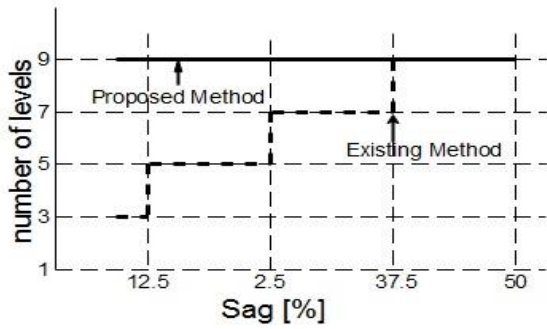


**Fig. 1.** Proposed Multilevel Inverter based DVR.

The dc-dc converter output dc voltage is transformed into high-frequency ac voltage. The primary side of a high-frequency transformer is supplied with high-frequency ac voltage with multiple secondary, and in this secondary, the H-bridge of the multilevel inverter; gets dc voltage by converting the high-frequency ac voltage. The H-bridge output is connected in series due to isolation, which is the transfer from the high transformer.



**Fig. 2.** Change the percentage of THD.



**Fig. 3.** Percentage of sag at different levels.

The quality of the voltage is directly linked to the number of voltage levels, and it increases in multilevel inverters. The below equations from 1 to 23 are studied in [20]

$$\alpha_i = \arcsin\left(\frac{i - 0.5}{n}\right) \quad i=1, 2, 3 \dots n \quad (1)$$

Where  $\alpha_i$  is the control method of the multilevel inverter, and it can be achieving as follows the nearest level control (NLC). Where  $\alpha_i$  is switching angle,  $n$  is the number of H-bridges.

The output voltage of  $h^{\text{th}}$  harmonic is written as below:

$$V_{0,h} = \frac{4V_{dc}}{h\pi} \sum_{i=1}^n (\cosh \alpha_i) \quad (2)$$

Where  $V_{0,h}$  is the  $h^{\text{th}}$  harmonic output voltage,  $\alpha_i$  is switching angle;  $V_{dc}$  is DC-link capacitor voltage.

$$V_{0,rms} = \frac{2\sqrt{2}V_{dc}}{\pi} \sqrt{\sum_{h=1}^n \left( \sum_{i=1}^n \frac{\cosh \alpha_i}{h} \right)} \quad (3)$$

Where  $V_{0,rms}$  is total RMS voltage,  $V_{0,1}$  is a fundamental component of RMS value.

The output voltage of Total Harmonic Distortion (THD) is given below:

$$THD = \sqrt{\left(\frac{V_{0,rms}}{V_{0,1}}\right)^2} - 1 \quad (4)$$

Where THD is the total harmonic distortion.

Using the above solutions, the variation of THD output voltage across the number of voltage levels is shown in fig 2. Furthermore, it displays when the number of voltage levels is maximum, and then the THD will be lowered. To develop output voltage with  $n$ -levels in all dimensions of operating point for  $n$ -level inverter, it will be relevant. This gets possible when the dc-dc converter with variable output voltage transfers the dc-link of the multilevel inverter. By placing the only on dc-link at each H-bridge, the injection transformer can be placed,

and where the transformer will act as an injection transformer at the same time. The injection transformer is used to combine the supply from dc-link and output voltage in H-bridges. The injection voltage and total resulting voltage are satisfying the voltage sags. Voltage swell may damage sensitive electronic appliances like television. The voltage sags consist of higher than 90% of all PQ problems. This is shown in the power quality survey, by seeing that the data collected in the survey says that there are less than 0.5pu voltage sags. For compensating a maximum of 0.5pu, the multilevel inverter based DVR is designed [21]. In the conventional multilevel inverter, the voltage sag ranges for several levels are mentioned in below table 1:

**Table 1.** Ranges of voltage sag at different levels.

Voltage levels	Voltage Sag Ranges
3 – Level Voltage	0.125 pu
5 – Level Voltage	0.125 pu to 0.25 pu
7 – Level Voltage	0.25 pu to 0.375 pu
9 – Level Voltage	0.375 pu to 0.5 pu

The multilevel inverter, which is places in DVR, continually works with the modulation index, which is equal to "1". It can increase the quality of the output voltage. The change of dc voltage and the modulation index change are the two ways to control the inverter output. Using the dc-dc converter, the input dc voltage of the multilevel inverter will be variable and controllable in DVR. The modulation index of the multilevel inverter will be stable by changing the input dc voltage, and it can also control the output voltage. The modulation index should be equal to its peak values. If the harmonic contents rise, then the power rating of the transformer will reduce excessively. The outcome of the output voltage will have a contraction in the size and rating of the injection transformer will have full effects on their lifetime. In this topology, the output filters are not used.

In this category, the calculations are done for the DVR. The calculations are given in general form due to the facts of any component of the DVR, such as a dc-dc converter, input dc voltage, and the transformer has its limits. However, the solutions are transparent to the design of the DVR is essential.

By implementing KVL for fig 1, the following equation is obtained as

$$V_{LV}(t) = V_{GV}(t) + V_{IV}(t) \quad (5)$$

Where  $V_{LV}$  is load voltage,  $V_{GV}$  is grid voltage, and  $V_{IV}$  is an injected DVR voltage.

By taking (6), the peak values of voltages are rewritten as

$$V_{LV} = V_{GV} + V_{IV} \quad (6)$$

$$V_D = V_{D,1} + V_{D,2} + \dots + V_{D,n} \quad (7)$$

$$V_C = V_{C,1} + V_{C,2} + \dots + V_{C,n} \quad (8)$$

Where  $V_D$  is the sum of all CHB output voltage, and  $V_C$  is the output voltage of the multilevel inverter.

By considering equation (9) and from section II fig. 1 the below equation will be

$$V_D = aV_C \quad (9)$$

Where  $a$  is turns ratio of injection transformer.

The peak value of the load is repeatedly equal to its nominal value when the DVR takes care of load voltage as shown below

$$V_{L,RMS} = V_L \quad (10)$$

Where  $V_L$ , ref is the peak load reference voltage.

The difference between the peak load voltage ( $V_{L,ref}$ ) and grid voltage is said to be voltage sag and the expression as given below.

$$V_S = V_{L,ref} - V_{GV} \quad (11)$$

Where  $V_S$  is the voltage sag.

By talking equations (10), (7) and (11) the below equation will get

$$V_C = \frac{V_S}{a} \quad (12)$$

The multilevel inverter peak value of output voltage is the product of modulation index ( $M$ ), number of CHBs ( $n$ ) and dc-link voltage ( $V_{dc}$ ) as shown below equation

$$V_d = \frac{V_C}{nM} \quad (13)$$

Where  $n$  is the number of CHB and  $M$  is the modulation index.

The voltage transfers ratio of the dc-dc converter ( $k$ ) is defined as the relation between the dc-link voltage and the input voltage of the dc-dc converter ( $V_i$ ) as shown below equation

$$k = \frac{V_d}{V_i} \quad (14)$$

Where  $k$  is the voltage transfer ratio of a dc-dc converter,  $V_i$  is an input voltage of the dc-dc converter;  $V_d$  is the dc-link voltage.

By replacing (14) and (15) in (13) then the equation is written as

$$V_S = anMkV_i \quad (15)$$

By taking the above equation, the following equation can be written as

$$k = \frac{V_S}{anMV_i} \quad (16)$$

If the modulation index ( $M$ ) is close to 1, then in the multilevel inverter, the number of output voltage levels will increase. The output voltage of the dc-dc converter is regulated due to the transfer ratio ( $k$ ) can be variable. The limits of dc-dc converter transfer ratio ( $k$ ) can be written as

$$k_{min} \leq k \leq k_{max} \quad (17)$$

Where  $k_{min}$  is the minimum output voltage of the dc-dc converter transfer ratio,  $k_{max}$  is the maximum output voltage of the dc-dc converter transfer ratio.

By multiplying the equation (16) to (18) get

$$(anMk_{min}V_i) \leq V_S^{pu} \leq (anMk_{max}V_i) \quad (18)$$

The above equation is specified per unit. The limits of the peak value of load voltage are the base of voltage ( $V_L=1pu$ ) can be written as

$$\left( \frac{anMk_{min}V_i}{V_{LV}} \right) \leq V_S^{pu} \leq \left( \frac{anMk_{max}V_i}{V_{LV}} \right) \quad (19)$$

The limits of  $M$  can be varying as follows

$$M_{min} \leq M \leq M_{max} \quad (20)$$

From the above equation, the voltage sag limits stated as written below

$$\left( \frac{anM_{min}k_{min}V_i}{V_{LV}} \right) \leq V_S^{pu} \leq \left( \frac{anM_{max}k_{max}V_i}{V_{LV}} \right) \quad (21)$$

It is an essential note, whereas, from the above equation, the range of the modulation index ( $M$ ) is modified even with a defined number of outputs voltage levels at maximum available ranges are developed.

**Table 2.** Ranges of voltage sags of different levels

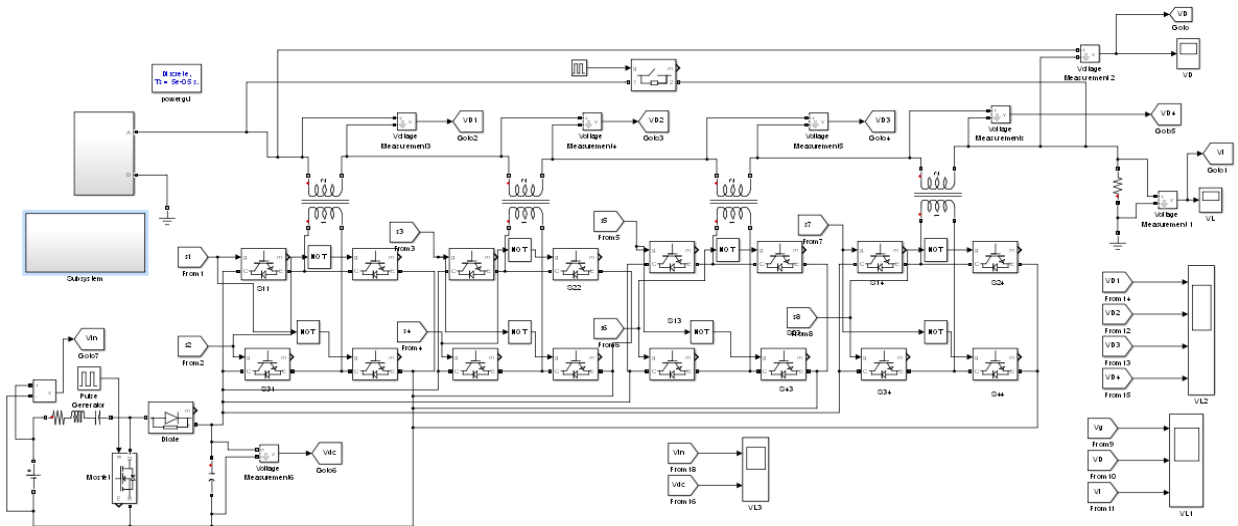
DC-DC Converter	$k_{min}$	$k_{max}$
Buck Converter	0	1
Boost Converter	1	Practical Limits
Buck-Boost Converter	0	Practical Limits

The above table shows the dc-dc converter voltage transfer ratio ( $k_{min}$  &  $k_{max}$ )

## 4 Simulation Results

The simulation of the proposed DVR is done in Simulink/MATLAB software. The operation of the proposed DVR indicates to grant in the simulation results. The nine-level inverter with DVR is preferred for simulation, which is shown in fig 4. The number of needed power electronic switches increases when the number of voltages increases. According to the concession between the number of switches and THD value should be studied. The nine-level cases are preferred by treated their factors in this paper. A different type of dc-dc converter that is a buck converter also be used. Some parameters are used in this paper, and they are shown in below table 3. The multilevel inverter switching is done by using the carrier wave values where the sag is given in 0.02pu. By using equation (20), the dc-dc converter input voltage ( $V_{in}$ ) can be obtained as

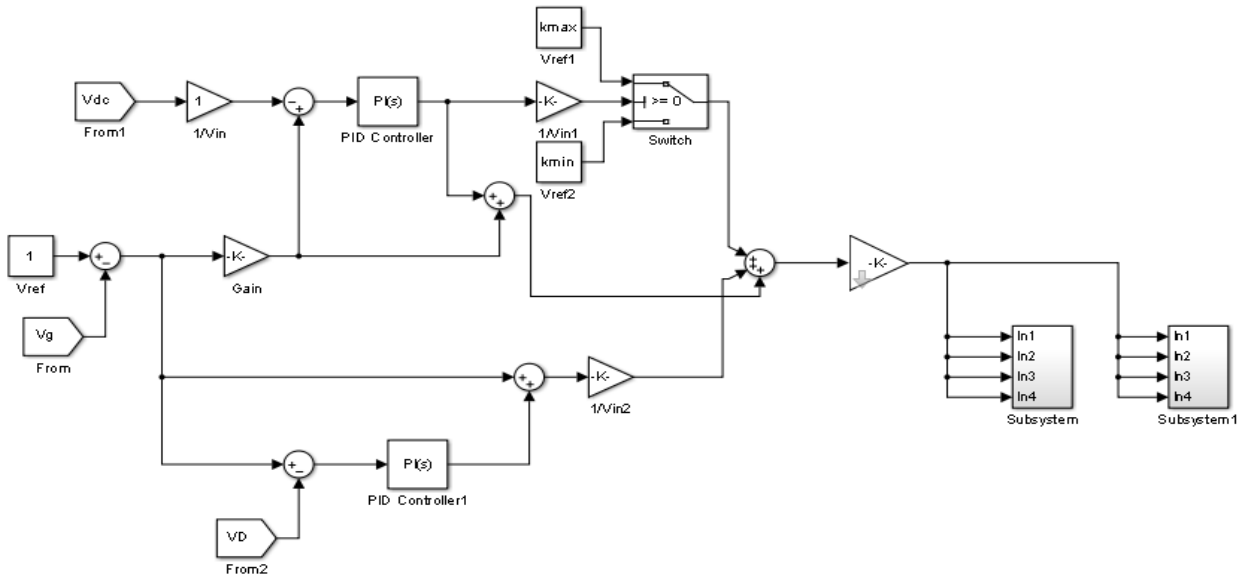
$$V_i = \frac{V_{S,max}^{pu} V_{LV}}{anMk_{max}} \quad (23)$$



**Fig. 4.** Nine levels inverter-based DVR

With the nine-level output voltage, the proposed multilevel inverter based DVR can compensate for voltage sags among 0.16pu and 0.5pu. It works within a wide range of voltage sags with its maximum number of voltage levels, and it is not possible in any other multilevel inverter.

Fig 5 shows the control strategy of the DVR block diagram. In this voltage sag ( $V_s$ ), which is equal to the reference value of DVR output voltage, the grid voltage ( $V_{GV}$ ) is subtracted from the DVR voltage ( $V_{DV}$ ), and by this, we can detect the voltage sag. Here the voltage sags and control system detected due to the quality exceed up to a certain threshold. The voltage sags occur at the detection time the time interval and time when voltage

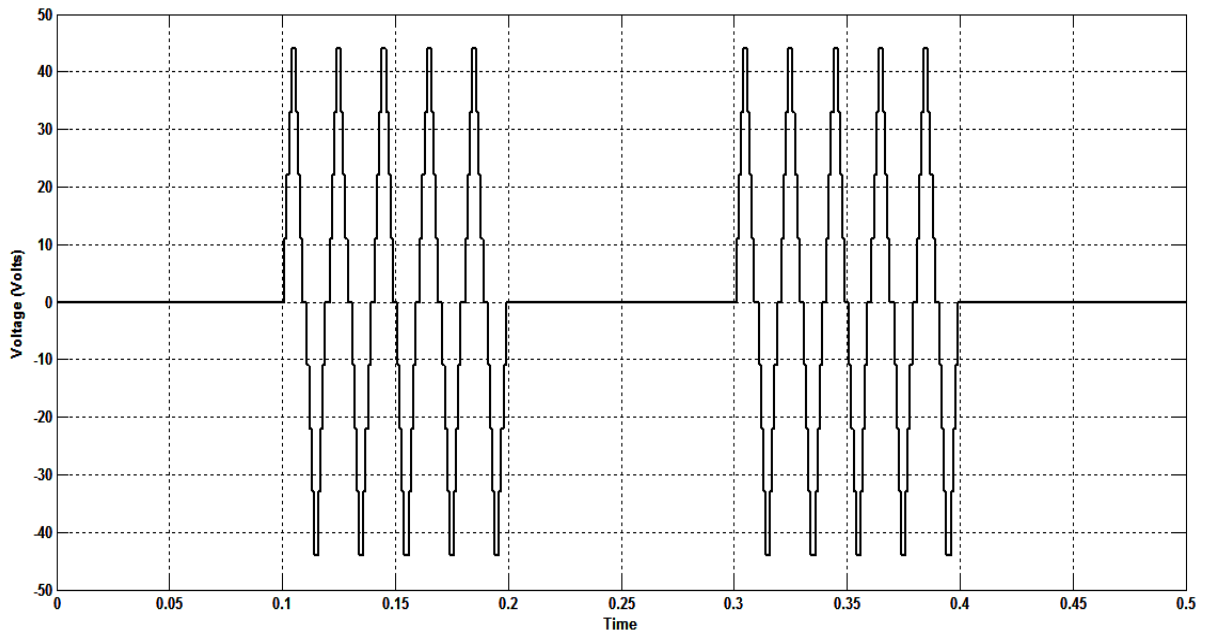


**Fig. 5.** Control strategy of DVR.

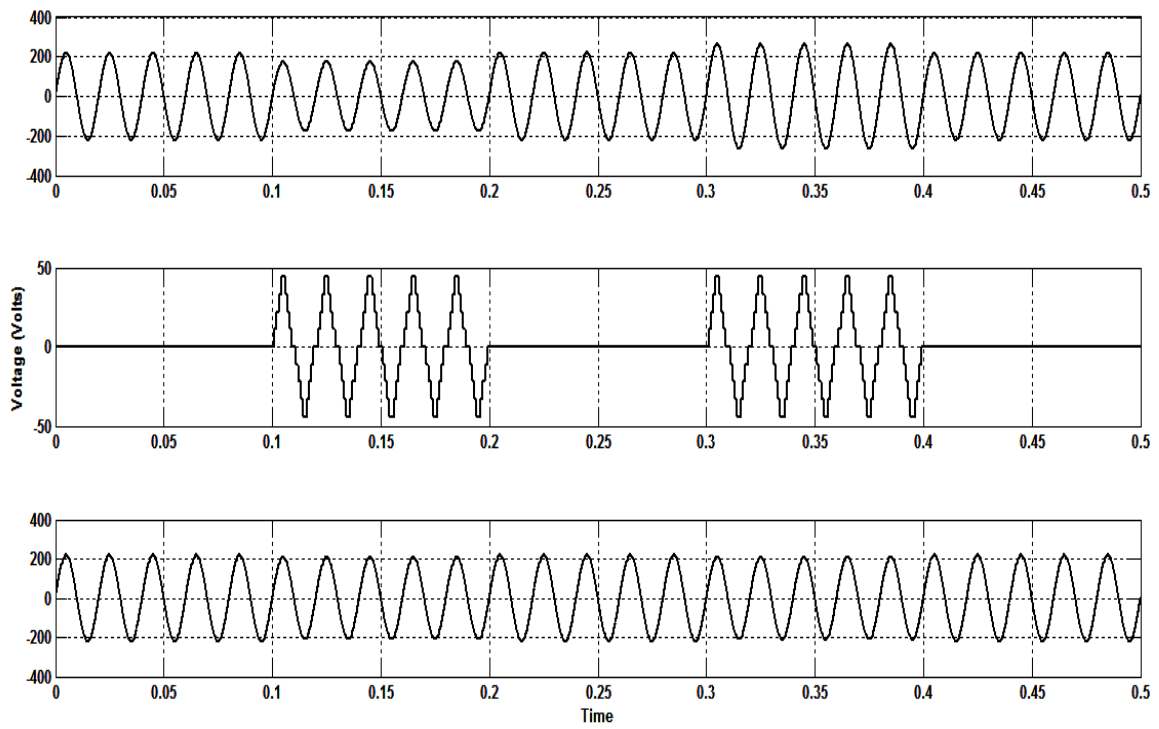
**Table 3.** Parameters and values of studied systems

Sl.no	Parameters	values
1	Boost Converter	$L=80\mu, k_{min}=1, k_{max}=3$
2	Load	$R=45\Omega, L=5mH$
3	Injection Transformer	$0.45+j3.5 \Omega, a=1:1$
4	dc-link capacitor	$5000\mu F$
5	Voltage peak	$V=220\sqrt{2}=1pu$
6	Number of levels	$N=1$

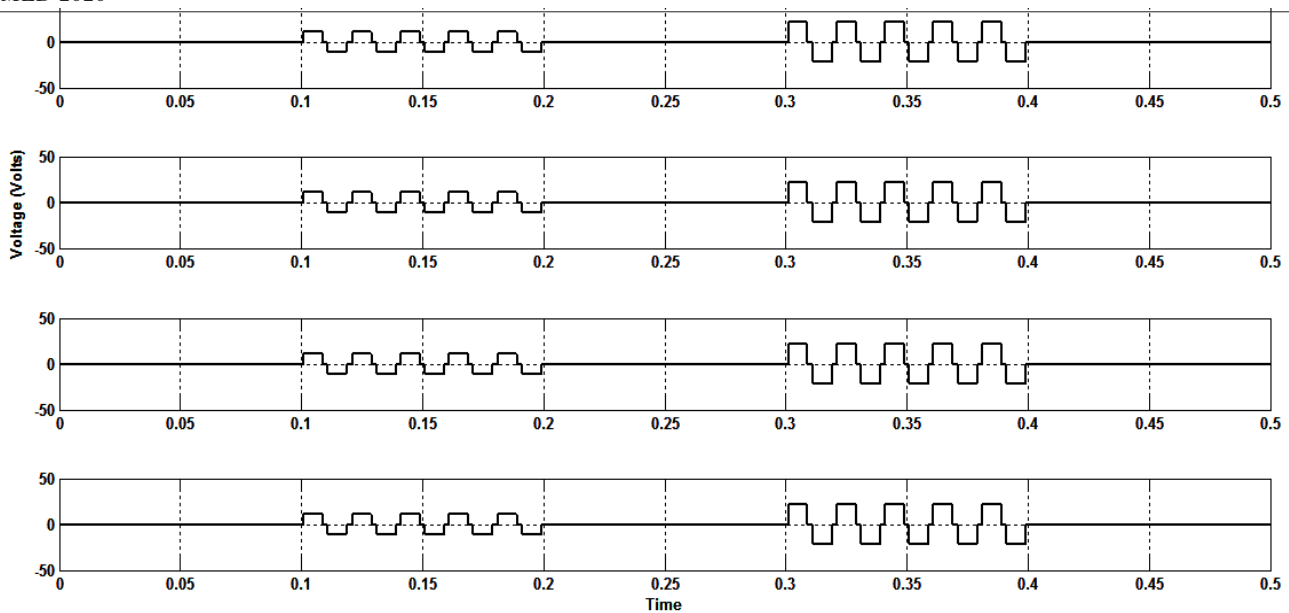
sag is compensated. These are dependent on the voltage improvement by DVR [22]. In order of feed-forward load, a feedback control with the PI controller is used to regulate the load voltage. The feedback and feed-forward output control is divided by the dc-link voltage and used as the reference for a multilevel inverter. The Nearest Level Control (NLC) is used to control the multilevel inverters [23]. Fig 6 shows the principle of a control method of a nine-level inverter. The output voltage with a maximum number of levels for different voltage sag depths has two different voltage sags with different depths that are applied to the grid voltage. By considering the voltage sag depth, the dc-link voltage is adjusted by the dc-dc converter.



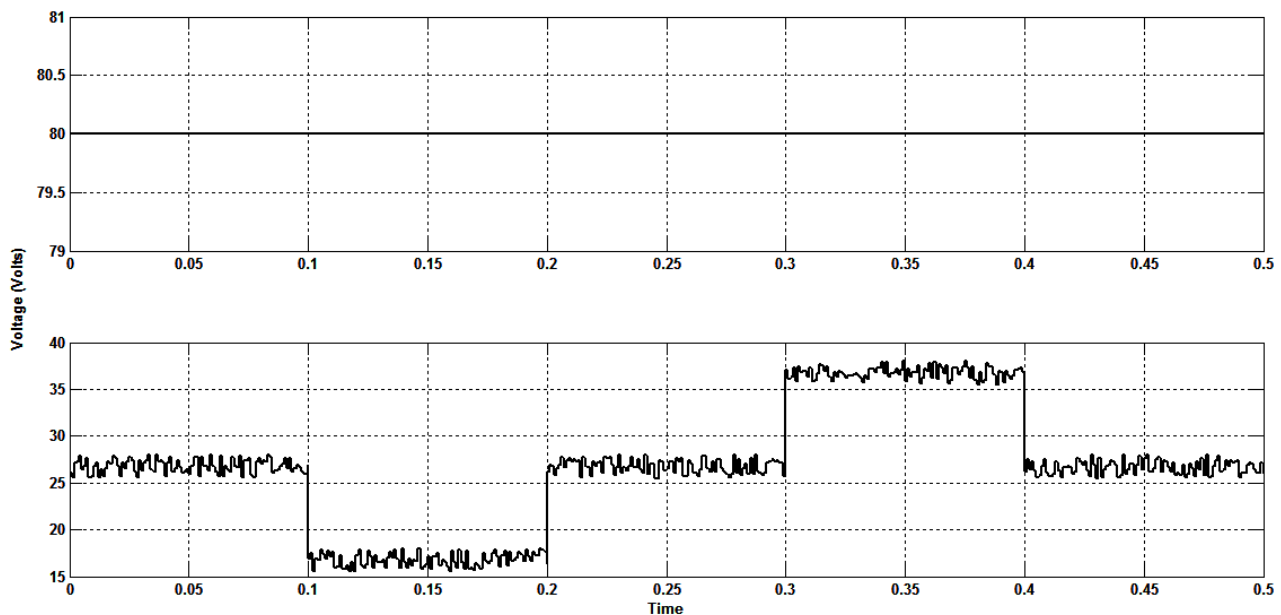
**Fig. 6.** Principle of NLC.



**Fig. 7.** Traces of grid, load, and injected voltages.



**Fig. 8.** Injected voltage waveforms.



**Fig. 9.** Input Voltage and dc-link voltage waveforms.

Fig 9 shows the output voltages of input voltage and dc-link voltage. The upper trace is input voltage of dc-dc converter and the value of the input voltage is 80v. The lower trace is dc-link voltage of dc-dc converter as the figure shows the value according to the voltage sag.

## Conclusion

In this paper, DVR based multilevel inverter with dc link adjustable voltage is implemented for good power quality. The dc-dc converter is used to regulate the dc-link accordingly to serve the power quality issues like voltage sag or transient voltage dip or voltage swell variations. Fundamental frequency control method is

used so that switching losses are reduced and filters are also eliminated. Here the simulation results of 9 level inverter based DVR gives a staircase waveform as shown in fig (6). This reduces voltage sag up to 50%.

## References

1. E. Babaei, M. Farhadi Kangarlu, M. Sabahi. Mitigation of voltage disturbances using dynamic voltage restorer based on direct converters. *IEEE Trans. Power Deliv*, Vol. 4. Iss. 25. pp. 2676-2683. (2010).
2. Y. Jiang, H. Liu, Q. Zheng, L. Zheng. A novel apparatus for adjusting the insertion voltage of transmission line based on variable inductors. *IEEE Trans. Power Deliv*. Vol. 1. Iss. 27, pp. 23-31. (2012)

3. F. Badrkhani Ajaei, S. Farhangi, R. Iravani. Fault current interruption by the dynamic voltage restorer. *IEEE Trans. Power Deliv.* Iss. 28, Vol. **2**. pp. 903-910.
4. S. Sasitharan, M.K. Mishra. Constant switching frequency band controller for dynamic voltage restorer. *IET Power Electron*, Vol. **5**, Iss. 3, pp. 657-667.
5. S. Saranya, T. Samina. Multilevel inverter based dynamic voltage restorer with hysteresis voltage control for power quality improvement. *IJSDR*. Vol. **1**, Iss. 10, ISSN. 2455-2631 (2016).
6. A.J. Visser, J.H.R. Enslin, H.T. Mouton. Transformerless series sag compensation with a cascaded multilevel inverter. *IEEE Trans, Ind Electron*, Vol. **4**. Iss. 49, pp. 824-831. (2002).
7. P.C. Loh, D.M. Vilathgamuwa, S.K. Tang and H.L.LONG Multilevel Dynamic Voltage Restorer. *IEEE Power Electron.*, vol.21, iss.4, pp.1053-1061, (2006).
8. V. K. Awaar, P. Jugge, and Tara Kalyani S. Mitigation of voltage sag and Power Quality improvement with an optimum designed Dynamic Voltage Restorer. *2016 IEEE International Conference on Power Electronics, Drives, and Energy System (PEDES)*, Trivandrum, (2016), pp. 1-5. DOI: 10.1109/PEDES.2016.7914365.
9. Al-Hadidi, H.K., Gole, A.M., Jacobson, D.A.: Minimum power operation of cascade inverter-based dynamic voltage restorer, *IEEE Trans. Power Del.*, 2008, 23, (2), pp. 889–898.
10. H.K.Al-Hadidi, A.M. Gole, D.A. Jacobson. A novel configuration for a cascade inverter-based dynamic voltage restorer with reduced energy storage requirements. *IEEE Trans. Power Deliv.* (2008), Iss. 23, Vol.**2**, pp. 881–888.
11. P.C. Loh, D.M. Vilathgamuwa, S.K. Tang, H.L. Long. Multilevel dynamic voltage restorer. *IEEE Power Electron.* (2004), Iss.2, Vol.4, pp.125–130.
12. C. Meyer, C. Romaus, R.W. DeDoncker. Five level neutral-point clamped inverter for a dynamic voltage restorer. *Proc. European Conf. on Power Electronics and Applications*, (2005)
13. J.D.Barros, J.F.Silva. Multilevel optimal predictive dynamic voltage restorer. *IEEE Trans. Ind. Electron.*, (2010), Iss.57, Vol. **8**, pp. 2747–2760.
14. P. Roncero-Sanchez, E. Acha. Dynamic voltage restorer based on flying capacitor multilevel converters operated by repetitive control. *IEEE Trans. Power Del.*, (2009), Iss. 24, Vol.**2**, pp. 951–960.
15. S. KOURO, R. BERNAL, H. MIRANDA, C. SILVA, and J. RODRIGUEZ. High performance torque and flux control for multilevel inverter fed induction motors. *IEEE Trans. Power Electron*, (2007), vol.**22**, iss.6, pp.2116-2123.
16. E. Babaei, S.H. Hosseini, G.B. Gharehpetian, M. Tarafdar Haque, M. Sabahi. Reduction of dc voltage sources and switches in asymmetrical multilevel converters using a novel topology. *Electric Power Syst. Res.*, (2007), Iss. 77, Vol. **8**, pp. 1073–1085.
17. E. Babaei, M. Farhadi Kangarlu. Operation and control of dynamic voltage restorer using single-phase direct converter. *Energy Convers. Manag.* (2011), Iss.52, vol. **8–9**, pp. 2965–2972.
18. M. PEREZ, J. RODRIGUEZ, J. PONTT, S. KOURO. Power distribution in hybrid multicell converter with nearest level modulation. *Proc. ISIE* (2007), Spain, pp.736-741.
19. Awaar. Vinay Kumar, Jugge. Praveen, and S. Tarakalyani. PQ Improvement by moderation of multilevel inverter controlling techniques and intensifying the performance of DVR. *Advances in Electrical and Electronic Engineering*, vol.**13**, no.2, (2015), Doi: 10.15598/aeec.v13i2.1244.
20. Ebrahim Babaei, Mohammad Farhadi Kangarlu, Mehran Sabahi. Dynamic voltage restorer based on multilevel inverter with adjustable dc-link voltage. *Published in IET Power Electronics*. (2013).
21. AWAAR V.K, JUGGE. P, and TARAKALYANI. Validation of control platform using TMS320F28027F for dynamic voltage restorer to improve power quality. *S.J Control Autom Electr Syst*, vol.**30**, (2019), 601.
22. N.S.Srivatchan, P.Rangarajan. Half cycle discrete transformation for voltage sag improvement in an isolated microgrid using DVR. *IJPEDS*, vol.**9**, no.1, (2018), pp.25-32, ISSN: 2088-8694.
23. Rodriguez, J., Franquelo, L.G., Kouro, S., et al.: Multilevel converters: An enabling technology for high power applications. *Proc. IEEE* (2009), Iss. 97, Vol. **11**, pp. 1786–1817.