

Applications of synchrophasor measurement to improve the reliability and efficiency of power systems

Alexandr I. Popov^{1,2*}, Alexey V. Mokeev^{1,2}, Sergey A. Piskunov¹, Andrey V. Rodionov¹

¹Engineering Centre “Energoservice”, Kotlasskaya st. 26, Arkhangelsk, Russia

²Northern (Arctic) Federal University, Electroenergetics and Electrotechnics Department, Severnaya Dvina emb.17, Arkhangelsk, Russia

Abstract. The article deals with the development of software and hardware systems that expand the scope of application of the synchrophasor measurement (SPM) technology. The following tasks are considered as applications: automation of 6-10 kV distribution networks with the possibility of localization a damaged cable line in case of single-phase earth faults, monitoring the state of power transformers, analyzing low-frequency oscillations in the power system.

1 Introduction

The use of the technology of synchrophasor measurement (SPM) makes it possible to create a new generation of control, monitoring, protection and automation systems, which increases the efficiency and reliability of the operation of power systems [1,2].

Initially, the field of application of the SPM technology was associated with transient monitoring systems. Currently, more and more attention is paid to expanding the scope of this technology for detecting dangerous and abnormal operating modes of power systems, monitoring the state of electrical equipment, automating distribution networks.

2 Distribution network automation

At most 6 (10) / 0.4 kV substations, there are no measuring current and voltage transformers, which significantly complicates the automation of networks, including finding a damaged cable or overhead line during short circuits and single-phase earth faults. Due to the low cost of transformer substations, their automation is economically justified only with relatively low costs for equipment, installation and commissioning work, maintenance of the substation automation system.

Inexpensive removable short-circuit current indicators have proven to be effective in detecting short circuits. It is much more difficult to determine the damaged line with a single-phase earth fault, especially in the case of a network with compensated neutral [3,4]. In such cases, the residual current and the direction of the zero sequence power are measured. This requires the installation of a residual voltage measuring transformer at the substation, which significantly increases the cost of equipment and also requires work to test the installed equipment.

To reduce the cost of substation automation, it is proposed to measure the residual current synchrophasors

instead of measuring the residual current and the direction of the zero sequence power, and in the distribution points - the residual current synchrophasors and residual voltage synchrophasors on the buses [5]. In this case, it is advisable to use removable residual current sensors installed on a 6-10 kV power cable.

The composition of the equipment for the automation of the transformer substation, developed by the specialists of Engineering Center Energoservice, is shown in Fig.1. For the localization of single-phase earth faults, a new device for measuring zero sequence synchrophasors ENLZ has been developed. The ENCM-3 data acquisition device with a built-in GPS/GLONASS-receiver carries out synchronization of the ENLZ time, collection and transmission of data from the ENLZ and short-circuit current indicators, control of the drive of switching devices through the ENMV-1 device. A distributed system for processing residual current and voltage synchrophasors is used to determine a damaged cable line in a single-phase earth fault. The listed set of devices can significantly reduce the cost of automating transformer substations and distribution city cable networks [5]. The functions of the system can be expanded through the use of intelligent metering devices in conjunction with removable current and voltage sensors, measuring network mode parameters, and power quality indicators.

To evaluate the residual current and voltage synchrophasors in ENLZ devices, an algorithm based on the windowed Fourier transform using specially synthesized time windows was implemented [6]. At the same time, a significant reduction in the requirements for the measurement accuracy of synchrophasors and time synchronization is permissible, in contrast to traditional PMU. The specified parameters are determined by the error of the residual current sensor (total relative measurement error 10%).

* Corresponding author: a.popov@ens.ru

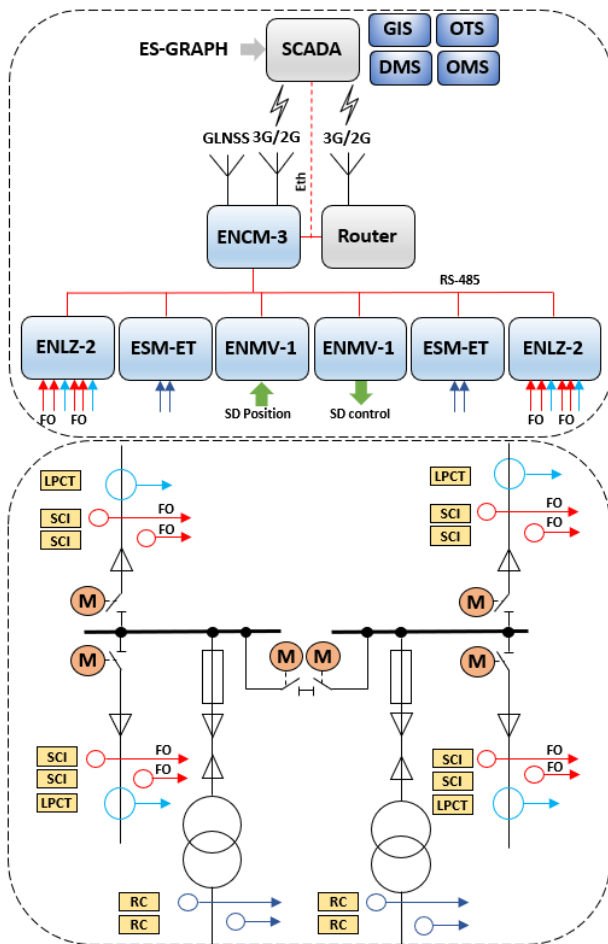

Fig. 1. Transformer substation automation

The localization boundaries of the single-phase earth fault location are determined by a pair of installed PMU. Devices can be equipped both on each cable line separately and on the whole network section. Depending on this, in the event of a single-phase earth fault, either a separate line or several cable lines entering the network section equipped with a pair of PMU will be localized. Thus, the customer has the opportunity to choose the most profitable localization option in terms of technical and economic indicators for each specific case.

Studies have shown that the distribution of residual currents over sections of the cable network is directly dependent on the capacitive current of each line, the active leakage current of the network insulation, the active resistance of the installed arc suppression reactors and the conditions for the occurrence of a single-phase earth fault. At the same time, in a network with a compensated neutral, it is far from always possible to determine the damaged line only by the magnitude of the current and voltage synchrophasors. Therefore, to detect the location of a single-phase earth fault, it is suggested to use the following information:

1. the residual voltage at the distribution point;
2. effective values of the residual currents at the beginning and end of the network section I_{01} and I_{02} (correspond to synchrophasor modules \dot{I}_{01} and \dot{I}_{02});
3. phase shift $\Delta\varphi$, equal to the angle between synchrophasors \dot{I}_{01} and \dot{I}_{02} ;

4. phase characteristic k_{Δ} , equal to the product of the phase shift $\Delta\varphi$ by the maximum effective value of I_{01} and I_{02} .

The order of localization of the damaged line is determined as follows. Synchrophasors of residual currents at the beginning and end of the line are defined as: $\dot{I}_{01} = I_{01}e^{j\varphi_1}$ and $\dot{I}_{02} = I_{02}e^{j\varphi_2}$. Then the phase shift is calculated by the formula:

$$\Delta\varphi = \varphi_1 - \varphi_2.$$

In undamaged sections of the network, $\Delta\varphi$ is determined by the active component of the leakage current and in most cases does not exceed 2-3 degrees. A single-phase earth fault current flows through the damaged section of the network with a compensated neutral, due to the active conductivity of the network and the resistance of the arc suppression coil. Thus, in the damaged area, the value of $\Delta\varphi$ can take on large values, up to 90 degrees.

The phase shift $\Delta\varphi$ also depends on the capacitive current of the line. The greater the line length and its cross-section, the greater its capacitive current and, accordingly, the greater the effective values of the residual currents at the beginning and end of the section. In this case, the active component of the leakage current of the section has a more gentle character of dependence on the parameters of the line and varies in much smaller limits than the capacitive current, which is due to certain requirements for the level of isolation of the network. Therefore, the phase shift $\Delta\varphi$ largely depends on the value of the capacitive line current: the larger it is, the less $\Delta\varphi$ is, as a rule.

Network sections with a large difference in the magnitude of the capacitive current when determining the location of a single-phase earth fault are characterized not only by $\Delta\varphi$, but also by the phase characteristic

$$k_{\Delta} = I_{0\max} \Delta\varphi.$$

The maximum value of k_{Δ} corresponds to the section of the network where a single-phase earth fault occurred. Thus, for each section of the network, k_{Δ} is determined and localization is performed on it.

Determination of the location of a single-phase earth fault and short circuit in cable distribution networks is carried out by the ES-Graph software package. A web interface is used to visualize the initial measurements and analysis results. The main scenario for detecting damage is based on data processing of messages about detected events according to the IEC 60870-5-104 protocol in the form of discrete signals, each of which corresponds to a section and type of process. The ES-Graph complex provides easy integration into existing systems, including SCADA, which significantly reduces the cost and accelerates the substation automation process.

The operation of the single-phase earth fault localization algorithm was tested in a virtual Simulink model using the example of a 10 kV distributed cable network (Fig. 2). The network is powered by a 110/10 kV step-down substation. On the 10 kV side, arc suppression reactors are installed, tuned for full compensation of the capacitive current of the network. The simulation also considered modes with the operation

of the reactor, providing under- and overcompensation of the capacitive current.

Fig. 2 shows the conditional directions of the residual currents by sections, their values are indicated at the beginning and end of the section in a complex form, the values of the phase characteristics and current of a single-phase earth fault. The phase characteristics are calculated according to the proposed algorithm. As can be seen from the diagram, the maximum k_{Δ} corresponds to the section where the short circuit occurred. When closing outside the investigated network (from the power supply side), k_{Δ} does not exceed the specified threshold value.

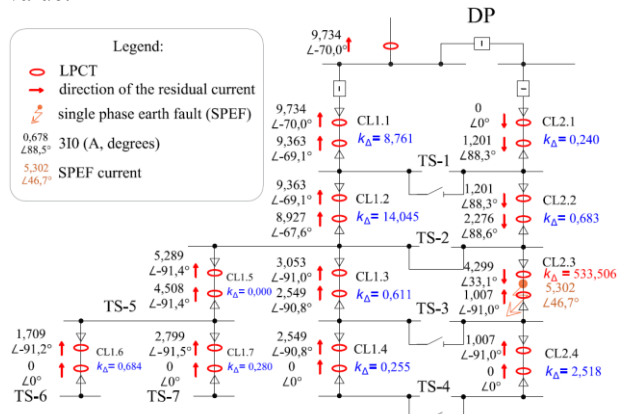

Fig. 2. Simulation of a distributed cabling network with a single-phase earth fault

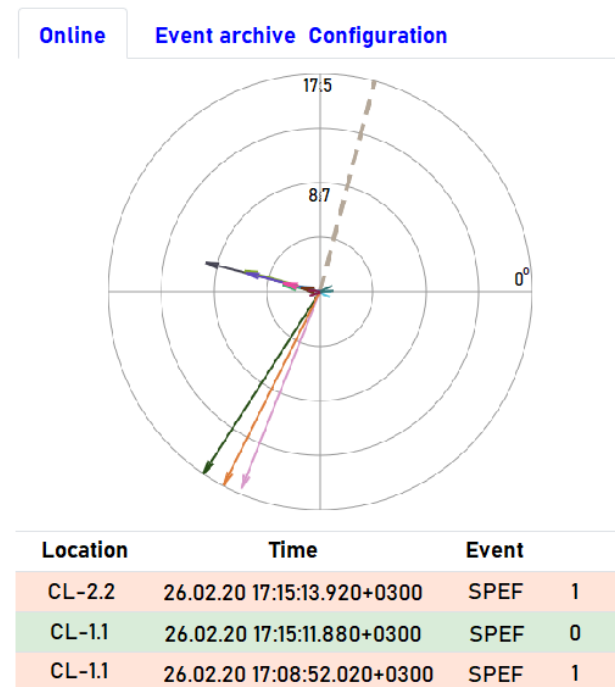

Fig. 3. Program web interface

To study the effectiveness of the proposed algorithm in the laboratory of Engineering Center Energoservice, the operation of the ES-Graph complex was tested on a physical model of a network with a compensated neutral. Fig. 3 shows the web interface of the system. The test results confirmed the high accuracy of the applied single-phase earth fault localization algorithm.

To implement a pilot project for a single-phase earth fault localization system in the network of IDGC of the North-West, PMUs were installed at several 6 / 0.4 kV transformer substations in the Arkhangelsk city cable networks. At the second stage of grid automation, electrically driven load break switches will be added to the listed components, which will ensure automatic restoration of the electrical network after a fault is detected.

Real and laboratory tests of the system were carried out at the facilities of JSC Grid Company, in particular, the system proved its efficiency by identifying an artificially created single-phase earth fault on one of the cable lines of Kazan city electric networks.

Currently, the software and hardware complex Digital RES is installed and is in trial operation at several transformer substations and distribution points of MUP «Electroset» in Cherepovets. The implemented system solves the problem of localizing accidents on cable lines, and also significantly increases observability, allowing the operating personnel to monitor the parameters of the network mode.

3 Monitoring the state of the power transformer

PMU can be considered as a logical development of multifunctional telemechanics measuring converters. Their application will make it possible to create a new generation of automated control systems [1]. In this regard, new opportunities are emerging. They are also related to the use of PMU for monitoring the state of power equipment and measuring current and voltage transformers [2].

The main component of the power transformer monitoring system of “Engineering center “Energoservice” is the ENIP-2-PMU synchrophasor measurement devices with a built-in GPS/GLONASS receiver and phasor data concentrator installed at a high and low voltage of the power transformer. Additionally, digital I/O devices of ENMV are used for monitoring the position of the OLTC, the state of the transformer blowing, temperature, humidity, and atmospheric pressure, etc. [7, 8]. The ESM multi-function measuring device installed on the low-voltage side of the transformer is designed to monitor the asymmetry and non-sinusoidality of currents and voltages. The software can be installed on an ENDC controller at a substation, or processing with cloud computing is being performed.

When organizing transformer monitoring, two main tasks are solved: determining the dynamics of changes in the transformer state assessment based on PMU data and identifying the parameters of the transformer equivalent circuit. The transformation ratio, magnetizing current, and no-load loss are calculated based on the parameters of the equivalent circuit. Based on the dynamics of changes in these parameters, it is possible to diagnose damage in the power transformer at the early stages [9].

Several algorithms for evaluating the parameters of the transformer replacement circuit have been tested in the research. The simplest of them is based on the

estimation of parameters for the L-type equivalent circuit and implements the known relationships between the complex amplitudes of currents and voltages and the parameters of the equivalent circuit. Magnetic interconnections between phases, transformer asymmetry, and non-sinusoidal magnetizing currents are not taken into account in this model. Also, large differences in resistances negatively affect the accuracy of parameter estimation. But despite these disadvantages, the algorithm allows us to effectively evaluate the dynamics in the parameters of the equivalent circuit.

When developing the transformer monitoring system, its mathematical modeling was performed using the MATLAB/Simulink software environment. As well as physical modeling based on transformers of small capacity in laboratory conditions was carried out. The results of modeling and testing were compared with each other.

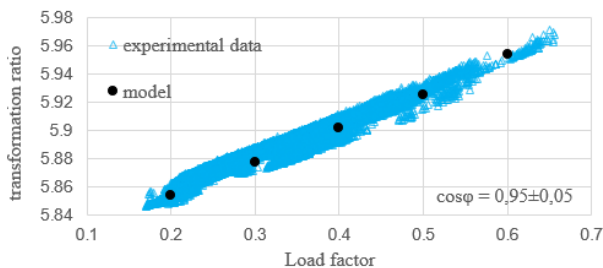

Fig. 4. Dependence of the transformation ratio on the load factor

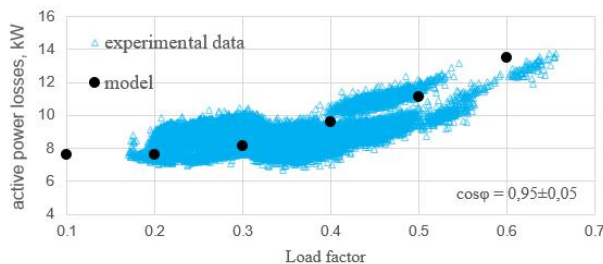

Fig. 5. Dependences of active power losses on the load factor

Experimental data obtained during laboratory tests on the values of the transformer's operating characteristics, active and reactive power losses, and the dependence of the transformation ratio on the load factor correspond to the values obtained in the mathematical model (Fig.4, Fig.5). Thus, knowing the main operating modes of the transformer, it is possible to predict the state of its parameters under certain conditions and, in the event of abnormal values that go beyond the allowed limits, signal the abnormal state of the transformer.

The results of the first stage of laboratory tests confirm that it is possible to make a fairly accurate calculation and control of active and reactive power losses, transformation ratio, parameters of the L-type equivalent circuit, and other electromagnetic parameters based on PMU data. The high frequency of measurements allows us to timely respond to any significant changes in these parameters.

A pilot project for monitoring the TD-10000/35 transformer was implemented at the 35/6 kV step-down

substation No.8 of the Arkhangelsk branch of PJSC ROSSETI. Most of the calculations are performed using cloud computing technology. The results of the pilot project confirm the effectiveness of replacing multifunctional telemechanics measuring converters at the substation with a multifunctional PMU with the implementation of power transformer monitoring functionality.

4 Analysis of low-frequency oscillations

The accumulation of measurement information, the increasing number and variety of measurement objects, and the increasing data availability provide the material for solving large-scale problems of analyzing the functioning of power systems. Within the framework of the problem working group of the Russian Committee B5 CIGRE, the authors are developing methods for analyzing low-frequency oscillation (LFO) and detecting their sources, while having records of real processes.

Improving the reliability and timeliness of determining the source of LFO when processing data online are current tasks in this field.

The structure of computational schemes in the analysis of LFO is characterized by a multi-stage processing process and the presence of many concrete implementations of each stage. An approach to the representation of calculations in the form of generalized graph structures that provides a two-step design procedure is proposed and developed in [10]: the system of related works is built at the first stage, the resulting scheme is filled with implementations of specific methods at the second one. This allows, on the one hand, to select a certain topology of the solution, and on the other, to ensure its necessary variability.

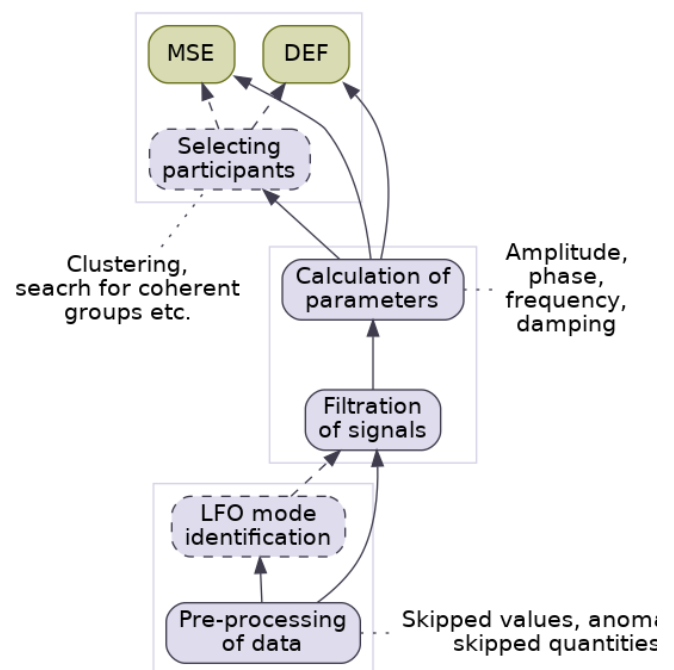

Fig. 6. Analysis of LFO and detecting their source

Also, working with a generalized representation of the process simplifies the combination of analysis methods, allowing us to reduce the load on computing resources, simplify system scaling, and organize the distributed computing. This approach is used to optimize the joint application of methods for determining the source of LFO: “Dissipating Energy Flow” (Def) [11] and “Mode Shape Estimation” (MSE) [12]. The combined data flow diagram is shown in Fig. 6. The data stream is shown as solid arrows, and control links are shown as dotted ones.

To increase the efficiency of using computing resources in [13], various parallelization strategies are proposed, in particular: dividing the input signal into overlapping sections and then assembling the result; dividing the input signal set into parallel processed subsets; simultaneous execution of ready-to-run nodes of the generalized scheme. Metrics for quantifying the implementation of parallelism in terms of the achieved acceleration, overhead, and the impact of the solution topology are presented in [14].

5 Conclusions

The conducted studies, the results of mathematical physical modeling, as well as the results of trial operation indicate, the effectiveness of using the SPM technology to improve the efficiency and reliability of power systems.

References

1. H.J.A. Ferrer, E.O. Schweitzer III (eds.), *Modern Solutions for Protection, Control, and Monitoring of Electric Power Systems*(SEL, Pullman, 2010).
2. *Synchrophasor Monitoring for Distribution Systems: Technical Foundations and Applications. A White Paper by the NASPI Distribution Task Team*, (NASPI, 2018).
3. V.A. Shuin, A.V. Gusenkov, Protection against earth faults in electrical networks 6-10 kV (Energoprogress, 2001).
4. A.I. Shalin, Electrical Engineering News, 3 (2005).
5. A.V. Mokeev, V.N. Bovykin, D.N. Ulyanov, Automation and IT in Energy, 10 (2019).
6. A.V. Mokeev, *IEEE International Siberian Conference on Control and Communications* (2017).
7. A.N. Blinov et. al., *2nd International Youth Scientific and Technical Conference «Relay Protection and Automation»* (2019).
8. A. Mokeev et. al., *CIGRE B5 Colloquium in Tromsø* (2019).
9. V.V. Smekalov, Automation and IT in Energy, 11, (2014).
10. A.I. Popov et. al. *2nd International Youth Scientific and Technical Conference on Relay Protection and Automation* (2019).
11. S. Maslennikov et al., International Journal of Electrical Power & Energy Systems 88 (2017).
12. M. Antonello, C. Muscas, F. Ponci, *Phasor measurement units and wide area monitoring systems* (Academic Press, 2016).
13. A. Popov et. al., Parallel Computing Technologies. PaCT, 11657 (Springer, Cham, 2019).
14. A. Rodionov et. al., *CIGRE SESSION 48* (2020).