

Study of the operation of a 110 MW combined-cycle power unit at minimum loads when operating on the wholesale electricity market

George Marin^{1,2}, Dmitrii Mendeleev^{1,2,*}, Boris Osipov¹

¹Kazan State Power Engineering University, 420034, Krasnoselskaya St., 51, Kazan, Russian Federation;

²JSC "Tatenergo" branch "Kazan CHP-2", 420036, Tatsevszkaya St., 11, Kazan, Russian Federation

Abstract. Currently, all generating equipment with a capacity of more than 25 MW operates in the wholesale electricity market. The operation of combined cycle gas turbines is complicated by the implementation of daily load schedules. A distinctive feature of the operation of combined-cycle units is the presence of a gas and steam turbine in the cycle. In this paper, the variable operating modes of a combined cycle plant are considered. The minimum effective load of a gas and steam turbine is determined. An example of the real operation of a steam turbine that is included in a combined cycle plant 110 MW power unit at an operating combined heat and power is shown. The optimal minimum load of a combined cycle gas turbine unit has been determined. As a result of the research, the values of high and low pressure steam flow rates, fuel gas consumption, steam and gas turbine power were obtained. Based on the research results, the optimal minimum load of a combined cycle gas turbine unit was found - 40 MW. This load allows the main and auxiliary equipment to work without compromising reliability.

Keywords: combined cycle plant, gas turbine unit, plant operating modes, electricity market, power dependence on external conditions, initial parameters

1 Introduction

According to the energy development strategy until 2035, the introduction of new generating equipment based on gas turbine units is envisaged. Gas turbines are used when upgrading or replacing used equipment. Nevertheless, at the same time, a lot of research is devoted to studying the work and increasing the efficiency of gas turbine plants [1].

When working on the wholesale electricity market, it is necessary to comply with the daily schedule of electrical loads. Gas turbine units have very good manoeuvrability. Starting and reaching the maximum load is possible in a very short period, no more than 30 minutes, therefore, use in half-peak mode is common when operating in a common power system [2-6].

The most important distinguishing feature of the steam-gas cycle from the steam cycle is the absence of a regenerative heating system for feed water and condensate. In the steam-gas cycle, the operation of a steam turbine depends on the amount and temperature of the exhaust gases after the gas turbine. Reducing the power of the gas turbine affects the operation of the waste heat boiler, steam turbine [7-10].

2 Materials and methods

This paper considers the problem of changing the main economic and energy characteristics of a combined cycle power unit at a minimum load.

For example, studies are being carried out at a 110 MW combined cycle gas turbines unit. The CCGT power unit includes a PG 6111 FA gas turbine unit manufactured by General Electric with a nominal capacity of 77 MW, one waste-heat recovery boiler manufactured by JSC «Emalliance» one steam turbine unit KT-33/36-7.5/0.12 manufactured by JSC «Kaluga Turbine plant» with one adjustable selection.

The waste heat recovery boiler is designed to generate superheated high and low-pressure steam through the economic and efficient use of heat contained in the combustion products of a gas turbine. The recovery boiler is part of a combined cycle power unit [11-13].

Tables 1 and 2 show the main parameters of the gas turbine unit and the waste heat recovery boiler.

* Corresponding author: dylankn@ya.ru

Table 1. Technical characteristics of a GTU (PG6111FA)

| No | Characteristic | Meas. unit | Value |
|----|---|---------------------|-------------|
| 1 | Power at the generator terminals | kW | 80000 |
| 2 | Atmospheric pressure | kgf/cm ² | 1.013 |
| 3 | Compressor inlet temperature | °C | 15 |
| 4 | Relative humidity at the compressor inlet | % | 60 |
| 5 | The pressure of the fuel before the gas module | kgf/cm ² | 25.9 – 30.8 |
| 6 | The number of stages in the compressor | pcs | 18 |
| 7 | The number of steps in the turbine | pcs | 3 |
| 8 | Air flow | m ³ /s | 166 |
| 9 | Compression ratio | | 15.8 |
| 10 | Air temperature after the compressor | °C | 385 |
| 11 | Flue gas temperature | °C | 603 |
| 12 | The temperature of the gases after the combustion chamber | °C | 1325 |

Table 2. Technical characteristics of a WHRB Ed-160/14-9.0/0.7-552/210

| No. | Characteristic | Meas. unit | Value |
|-----|---|------------|-------|
| 1 | Steam production of high pressure circuit | t/h | 160 |
| 2 | Steam production of low pressure circuit | t/h | 14 |
| 3 | High pressure steam pressure (abs.) | MPa | 9.0 |
| 4 | Low pressure steam pressure (abs.) | MPa | 0.7 |
| 5 | High pressure steam temperature | °C | 552 |
| 6 | Low pressure steam temperature | °C | 210 |

The thermal diagram of the power unit is shown in Fig. 1.

A mathematical model has been created for research. The mathematical model is built according to the following block diagram (Fig. 2)

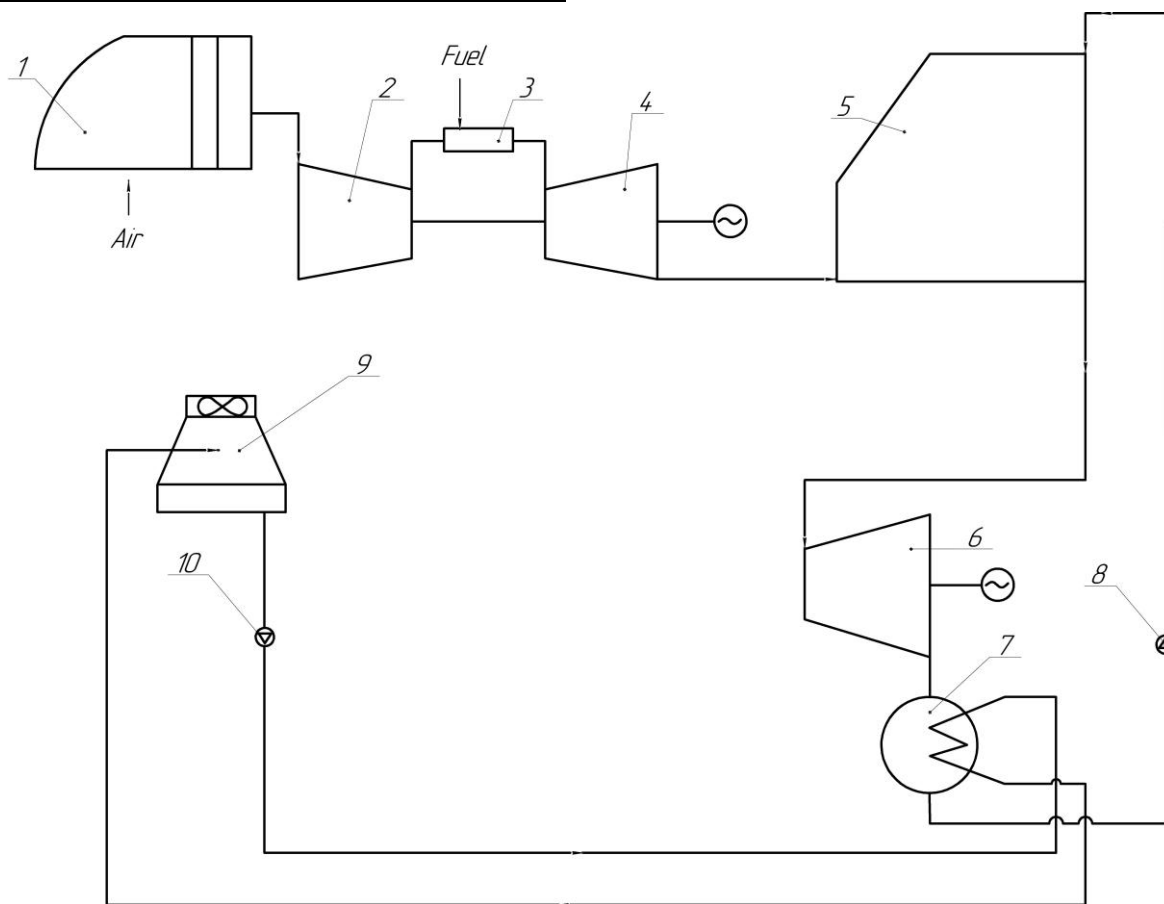

Fig. 1. Thermal diagram of the combined cycle gas turbines 110 MW power unit

1 – an air filtering and conditioning system; 2 – a compressor; 3- a combustion chamber; 4 – a gas turbine; 5 – a waste heat recovery boiler; 6- a steam turbine; 7 – a capacitor; 8.10 – a pump; 9 – a fan cooling tower

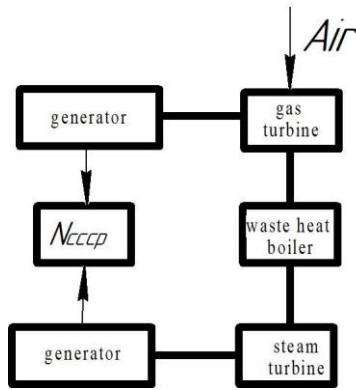

Fig. 2. Block diagram of the mathematical model of the combined cycle gas turbines

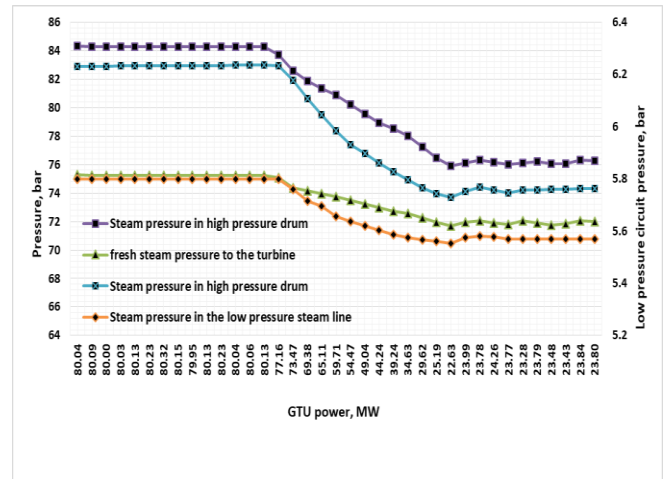

Fig. 4. Dependences of the vapor pressure of the high and low-pressure circuits on the loading of the gas turbine unit.

3 Results and Discussion

Despite the wide maneuverability of the gas turbine, the maneuverability of the steam circuit must be taken into account. When the load of the gas turbine decreases, the pressure and temperature of the high-pressure steam decrease, the parameters of the low-pressure steam remain unchanged. The steam turbine must be turned off at a high-pressure steam temperature of 460 °C, a pressure of 57 kgf/cm², therefore, a decrease in steam parameters to these values is unacceptable. It is also unacceptable to reduce the power of the steam turbine below 8 MW, so at a power of 7.2 MW it is necessary to disconnect the intermediate low pressure input.

For the study, a limitation of the minimum steam pressure in the turbine head of 57 kgf/cm² was introduced; at this pressure, the circulation in the heat exchange tubes of the waste heat boiler may deteriorate. In fig. Figures 3-7 show graphical dependencies of the power unit operation and its parameters. [14-16]

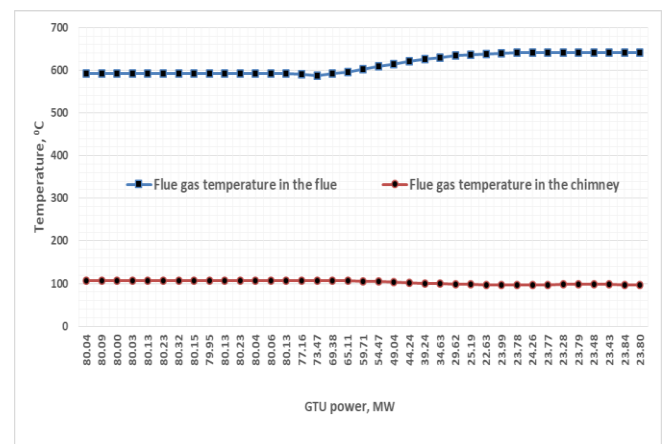

Fig. 5. Dependences of the temperature of flue gases in the gas turbine duct and in the chimney on the gas turbine load.

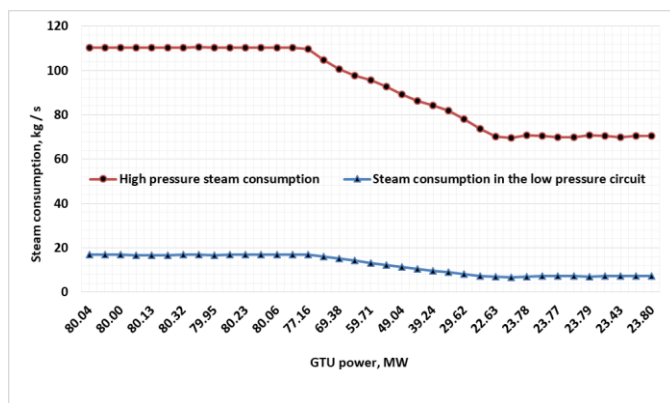

Fig. 3. Dependences of steam flow rates of high and low pressure circuits on the loading of the gas turbine unit. (The consumption of low and high-pressure steam with increasing load on the gas turbine grows almost linearly; this is due to a smooth increase in the temperature of the turbine exhaust gases).

4 Conclusion

1. The dependences of the output parameters (high and low pressure steam flow rates, high and low pressure steam pressure,) on the loading of the combined cycle power unit were obtained. These dependences make it possible to quickly determine the operating characteristics of the power unit.
2. The data obtained make it possible to predict changes in the main parameters of the combined cycle plant. [17-19]
3. Based on the research results, the constant minimum power of the CCGT unit was determined - 40 MW. (gas turbine capacity - 23.5 MW, steam turbine capacity - 16.5 MW). With such a minimum load, the power unit can operate for a long time

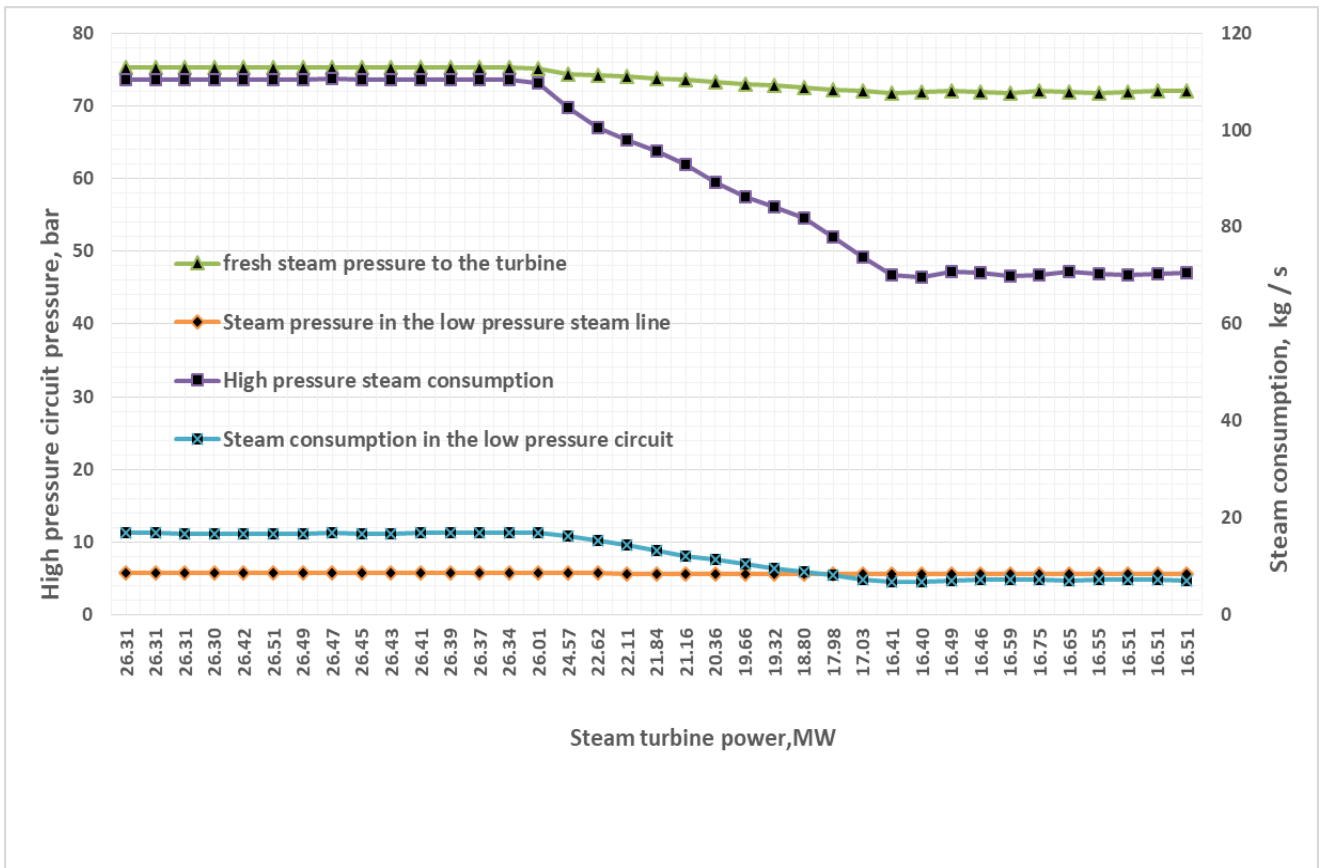

Fig. 6. Dependences of pressure and steam flow rates of high and low pressure circuits on the load of the steam turbine unit.

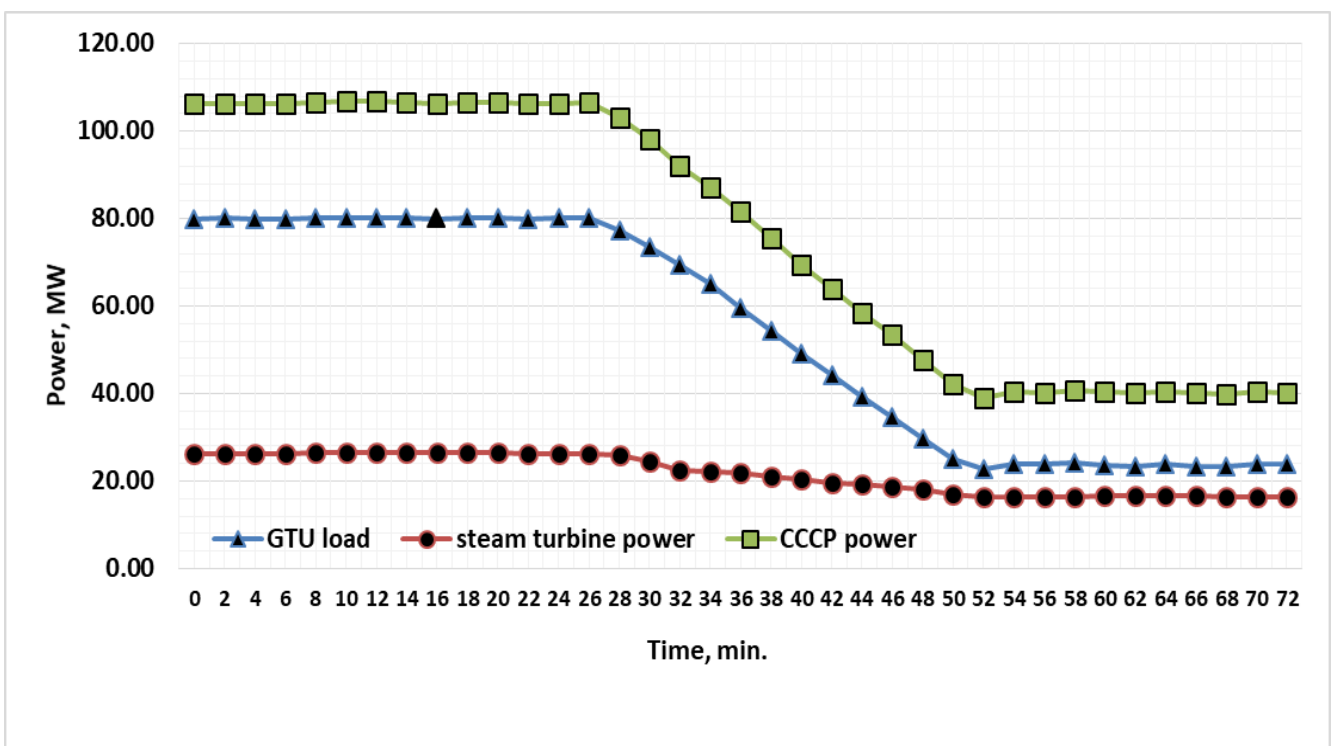

Fig. 6. Dependences of the capacities of the gas, steam turbines and power unit over time in the unloading mode

References

1. J. Y. Shin, Y. J. Jeon, D. J. Maeng, J. S. Kim, and S. T. Ro, *Energy* (2002)
2. A. D. Rao, *Combined Cycle Systems for Near-Zero Emission Power Generation* (2012)
3. A. L. Polyzakis, C. Koroneos, and G. Xydis, *Energy Convers. Manag.* (2008)
4. D. I. Mendeleev, G. E. Maryin, and A. R. Akhmetshin, in *IOP Conf. Ser. Mater. Sci. Eng.* (2019)
5. D. I. Mendeleev, Y. Y. Galitskii, G. E. Marin, and A. R. Akhmetshin, *E3S Web Conf.* 124, (2019)
6. E. León and M. Martín, *Energy Convers. Manag.* (2016)
7. J. Kern, in *Energy Conversion*, Second Ed. (2017)
8. P. Ivanova, E. Grebesh, and O. Linkevics, *Latv. J. Phys. Tech. Sci.* (2018)
9. T. K. Ibrahim, M. M. Rahman, and A. N. Abdalla, in *Procedia Eng.* (2011)
10. J. H. Horlock and W. W. Bathie, *J. Eng. Gas Turbines Power* (2004)
11. Y. Haseli, I. Dincer, and G. F. Naterer, *Int. J. Hydrogen Energy* (2008)
12. E. Gracheva and A. Alimova, in *Proc. - 2019 Int. Ural Conf. Electr. Power Eng. Ural. 2019* (2019)
13. L. Esclapez, P. C. Ma, E. Mayhew, R. Xu, S. Stouffer, T. Lee, H. Wang, and M. Ihme, *Combust. Flame* (2017)
14. R. Canepa, M. Wang, C. Biliyok, and A. Satta, *Proc. Inst. Mech. Eng. Part E J. Process Mech. Eng.* (2013)
15. J. M. Beér, *Prog. Energy Combust. Sci.* (2007)
16. M. Basha, S. M. Shaahid, and L. Al-Hadhrami, in *Energy Procedia* (2012)
17. O. O. Badran, in *Appl. Energy* (1999)
18. M. Ameri, P. Ahmadi, and S. Khanmohammadi, *Int. J. Energy Res.* (2008)
19. *Choice Rev. Online* (1991)