

# Simulation and Experimental Research on Overvoltage Measurement of Hybrid CVT

Yu Nie<sup>1</sup>, Guoqing Zhang<sup>1</sup>, Jiakuo Song<sup>1</sup> and Guizhong Wang<sup>2</sup>

<sup>1</sup> Department of Electrical Engineering, Harbin Institute of Technology, Harbin, Heilongjiang, China

<sup>2</sup> Hebei Key Laboratory of Grid Advanced Measurement and Monitor

**Abstract.** The CVT equipment running on site is slightly modified to form a hybrid CVT to achieve transient overvoltage measurement, which is theoretically feasible and practical. In order to study the voltage division method based on the hybrid CVT to measure the overvoltage of the power system, that is, the low voltage capacitor C3 is connected in series between the low voltage terminal of the medium voltage capacitor C2 of the traditional CVT and the ground, and the transient overvoltage measurement is realized through C3. This article uses ATP-EMTP to establish its high-frequency transient model for simulation analysis. For further verification, a power frequency voltage test and an impulse voltage test were carried out on the 110kV hybrid CVT produced by Taikai Transformer Factory, focusing on the analysis of the partial voltage characteristics of the capacitor C3. The simulation results show that the C3 partial pressure method can achieve a relatively accurate measurement of the transient overvoltage. The test results show that the voltage across C3 is affected by uncertain factors and has an impact phenomenon. The above analysis process and results have certain practical value for designing actual products.

## 1 Introduction

In the power system, capacitive voltage transformers (CVT) are mainly used for high-voltage voltage measurement equipment[1], but it focuses on power frequency signal measurement and cannot cope with the challenges posed by broadband signal measurement, and transient overvoltage signals contain abundant frequencies, so there is currently a lack of complete transient overvoltage measurement devices. Due to the inertial components such as inductance and capacitance inside the capacitive voltage transformer, the measurement frequency range is narrow, and the measurement is accurate only under the power frequency condition. Moreover, its transient response characteristics are poor[2-4]. When the primary side voltage changes suddenly, and the secondary side output voltage cannot immediately respond to the change of the primary voltage.

In order to realize the wide-band measurement of CVT[5], which is widely used at present, the CVT equipment running on the spot is slightly modified, and a large capacitor C3 is connected in series to form a hybrid CVT, which realizes the measurement of transient overvoltage, and have the characteristics of convenient installation, stable and reliable operation, wide frequency coverage and fast response speed. This paper draws on relevant research results, combined with the actual parameter values of the series-parallel CVT of 110kV voltage level, built a high-frequency simulation model of

the series-parallel CVT in ATP-EMTP, and the partial pressure characteristics of the capacitor C3 under different conditions are analyzed and verified by experiments.

## 2 Hybrid CVT structure and principle

Hybrid CVT is a series connection of low-voltage capacitor C3 between the low-voltage terminal of the medium-voltage capacitor C2 of the traditional capacitive voltage transformer and the ground, and it has the original measurement function of the CVT and the transient voltage measurement function at the same time. The basic structure principle of the Hybrid CVT is shown in Figure 1, which consists of two parts: a capacitor voltage divider unit and an electromagnetic unit.

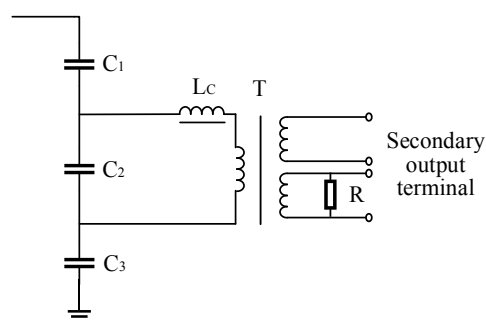

Figure 1. Hybrid CVT structure diagram

<sup>1</sup> e-mail: nieyu2885@outlook.com

The capacitor voltage divider unit includes the upper section high voltage capacitor C1, the lower section voltage divider capacitor C2, and the series connected low voltage capacitor C3. The function of the capacitor voltage divider unit is to extract the high voltage U1 on the primary side into the output voltage UC2 of the lower capacitor. The relationship between the output voltage UC2 of the traditional CVT capacitor C2 and the primary side voltage can be expressed as

$$\frac{U_1}{U_{C_2}} = \frac{C_1 + C_2}{C_1} \quad (1)$$

Then the voltage divider ratio KC of the capacitor voltage transformer can be expressed as

$$K_C = \frac{C_1 + C_2}{C_1} \quad (2)$$

Since the capacitance value of C3 connected in series is much larger than C1 and C2, the relationship between the output voltage of capacitor C2 and the primary side voltage can be expressed as

$$\frac{U_1}{U_{C_2}} = \frac{C_1 + C_2}{C_1} + \frac{C_2}{C_3} \approx \frac{C_1 + C_2}{C_1} \quad (3)$$

Therefore, the voltage division ratio of the original CVT remains basically unchanged, C3 has no effect on

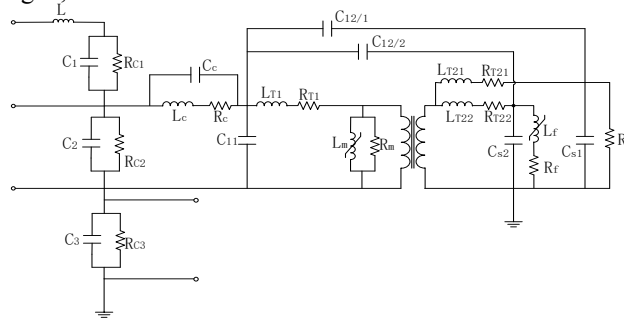

**Figure 2.** High-frequency transient simulation model of hybrid CVT

Capacitors C1, C2, C3 (including its dielectric loss RC1, RC2, RC3 and lead parasitic inductance L); Compensation reactor LC (including its resistance RC and stray capacitance CC); intermediate transformer (RT1 and LT1 are the resistance and inductance of the primary winding of the intermediate transformer, Rm and Lm are the resistance and inductance of the excitation branch of the intermediate transformer, RT21, RT22, LT21 and LT22 are the resistance and inductance of the load and damping winding on the secondary side of the intermediate transformer; the equivalent inductance Lf and equivalent resistance Rf of the fast saturation reactor;

the voltage output of the secondary terminal of the CVT electromagnetic unit.

The electromagnetic unit includes a compensation reactor LC, a medium voltage transformer T, a damper R and a secondary output terminal. The electromagnetic unit connects the extracted lower capacitor voltage UC2 to the primary winding of the medium-voltage transformer, and transforms it into the secondary voltage signal used by the system metering, relay protection device, and control system through the medium-voltage transformer.

### 3 Simulation Analysis of Hybrid CVT

Combining the wave process theory of the voltage transformer for the establishment of the stray and distributed capacitance of the CVT model, as well as the actual measurement and calculation of the parameters of each component, the establishment of the corresponding high-frequency transient simulation model is shown in Figure 2. The voltage across C3 and the output voltage on the secondary side have been converted to the high voltage side according to the corresponding voltage division ratio and rated transformation ratio.

Side winding load R2; C12 is the stray capacitance between the primary and secondary windings; C11 is the stray capacitance of the primary winding; Cs1 and Cs2 are the stray capacitances of the secondary winding.

#### 3.1 Comparative analysis of the secondary side output voltage and the voltage across C3

When the input voltage is 20kV lightning overvoltage, the waveforms of the input voltage, the secondary side output voltage and the voltage across C3 are shown in Figure 3.

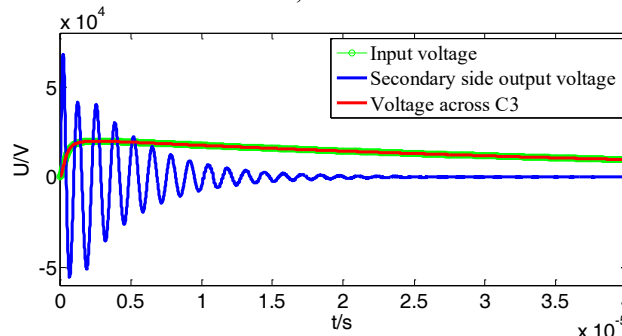

**Figure 3.** Comparison of input voltage waveform and output voltage waveform of each terminal

It can be seen from the voltage waveform on the secondary side has a certain distortion, which cannot fully reflect the true waveform of the lightning overvoltage. From the above analysis, it is actually the electromagnetic unit structure that affects its existing direct measurement of lightning intrusion wave overvoltage waveform on the secondary side. The voltage waveform at both ends of C3 can better reflect the input voltage of the primary side.

### 3.2 Simulation results and analysis of lightning impulse overvoltage

Use ATP-EMTP to simulate the hybrid CVT model, input +20kV lightning impulse voltage, the input voltage of the hybrid CVT and the waveform of the voltage across C3, different conditions. The simulation results are as shown in the following figures.

(1) When there is no electromagnetic unit

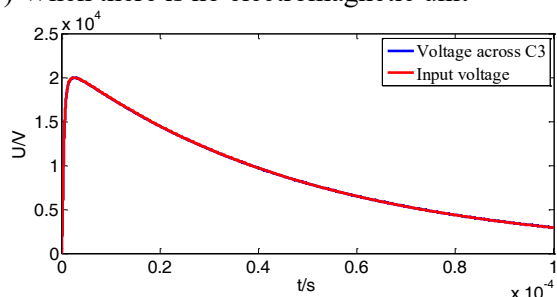

Figure 4. Output voltage and input voltage at both ends of C3 without electromagnetic unit

(2) When the electromagnetic unit is included and the CVT is running at no load

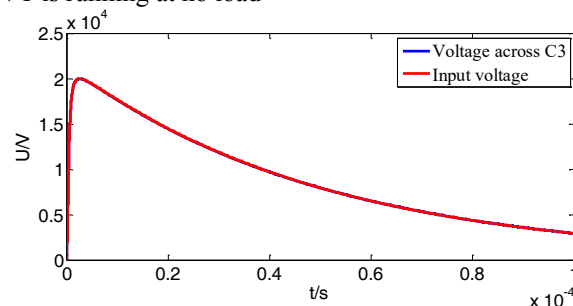

Figure 5. Output voltage and input voltage at both ends of electromagnetic unit C3 at no load

(3) Including electromagnetic unit, when 1a-1n winding is connected to 10VA rated load

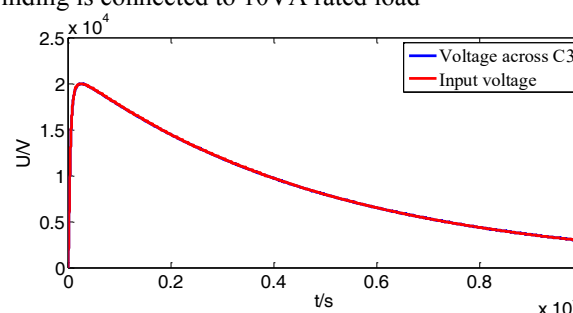

Figure 6. Output voltage and input voltage at both ends of electromagnetic unit C3 with 10VA load

Table 1. Comparison of parameter values

parameter	Input voltage	Voltage across C3		
		No electromagnetic unit	With electromagnetic unit (1a-1n no load)	With electromagnetic unit(1a-1n with 10VA load)
Wave head time(μs)	2.6	2.61	2.55	2.64
Half peak time(μs)	38.57	38.55	38.58	38.56
Peak(kV)	20	6.4159	6.4068	6.4075
Partial pressure ratio	3117.5600	3117.2556	3121.6832	3121.3422

The waveform parameter comparison of the simulation results is given in the table. It can be seen that the voltage divider ratios of the voltage output from both ends of C3 under different conditions are 3117.2556, 3121.6832, and 3121.3422, which are similar to the rated voltage divider ratio of the CVT, with the largest relative deviation. It is 0.13%; the voltage output from both ends of C3 is similar to the impact time parameter of the input lightning overvoltage. The simulation results show that the two ends of the capacitor C3 connected in series in the hybrid CVT can be used to measure the lightning overvoltage waveform.

### 4 Overvoltage waveform measurement test and analysis

This article is designed to test the transient overvoltage of the 110kV hybrid CVT used in the test. The overvoltage test device used is the product used in the test produced by Taikai Transformer Factory, the model is TYD110/√3-0.01H-hybrid Type CVT. The specific wiring diagram of the whole set of device test is shown in Figure 7. The parameters of this 110kV hybrid CVT are shown in Table 2. The capacitances of C1, C2, and C3 are 10200pF, 64530pF, and 27.45μF, respectively. The voltage source of the impulse voltage test is a 20kV impulse voltage generator SUG255TX, and the sampling

frequency of the test oscilloscope is 5GHz. Select the three channels in the oscilloscope to sequentially connect the lightning impulse voltage signal output by the attenuation probe; the voltage signal output from the secondary side terminals 1a-1n of the intermediate transformer of the electromagnetic unit through the coaxial shielded cable; the two ends of C3 are output through the coaxial shielded cable Voltage signal.

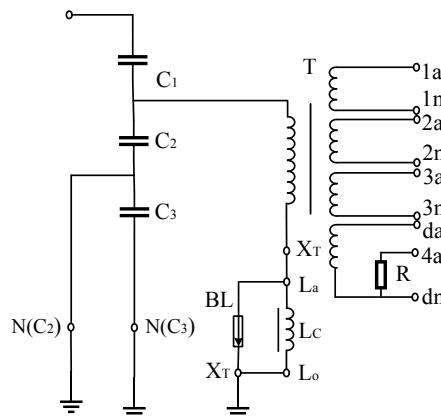

**Figure 7.** Test wiring diagram

**Table 2.** Main parameters of 110kV hybrid CVT for test

Parameter name	Parameter value			
Rated primary voltage(kV)	$110/\sqrt{3}$			
Medium voltage transformer rated voltage(kV)	10			
Secondary winding terminal mark	1a-1n	2a-2n	3a-3n	da-dn
Rated secondary voltage(kV)	$0.1/\sqrt{3}$	$0.1/\sqrt{3}$	$0.1/\sqrt{3}$	0.1
Accuracy	0.2	0.5	3P	3P
Rated output(VA)	10	10	10	10

**4.1 Power frequency voltage test results**

The power frequency voltage generator inputs 1200V power frequency sinusoidal alternating current, and the

waveform comparison between the input voltage and the voltage across C3 is shown in the figure below.

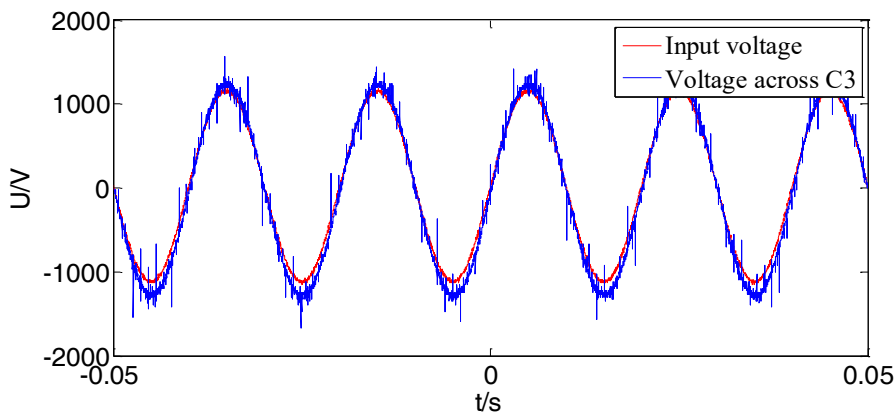
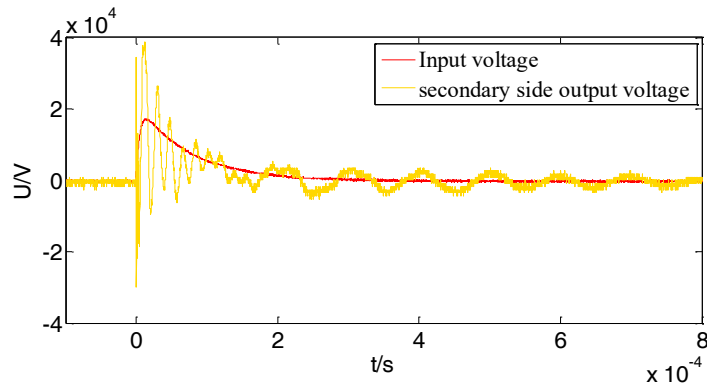

**Figure 8.** The input voltage and the voltage waveform at both ends of C3

The voltage waveform obtained through both ends of C3 is basically the same as the input voltage waveform. There is almost no deviation in frequency, and there is only a difference in amplitude. From the voltage waveform obtained from multiple measurements, the voltage divider ratio can be calculated: the voltage divider at both ends of C3 The ratio is similar to the calculated rated partial pressure ratio, and the relative deviation is about 3%.

**4.2 Impulse voltage test results**

When the impulse generator inputs a 20kV lightning overvoltage, the waveforms of the input voltage and the secondary side output voltage are shown in the figure below.



**Figure 9.** Input voltage and secondary side output voltage waveform

When the input amplitude is +5kV lightning overvoltage, the waveforms of the input voltage and the voltage across C3 are shown in the figure below.

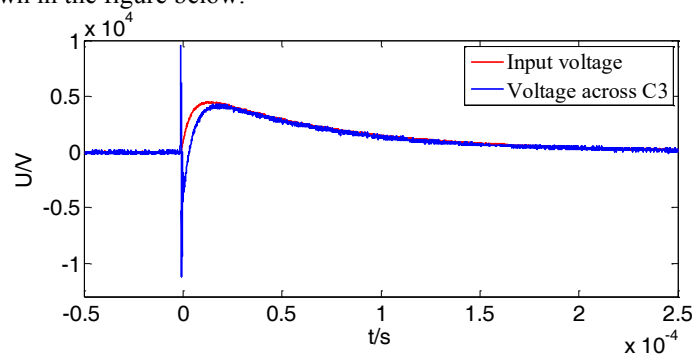

**Figure 10.** The input voltage and the voltage waveform at both ends of C3

## 5 Conclusion

This paper studies the characteristics of C3 partial pressure in a series-parallel CVT, uses ATP-EMTP software to simulate it, and conducts a power frequency voltage test and an impulse voltage test respectively, and analyzes the voltage waveform output at both ends of C3, including Voltage ratio, voltage amplitude, frequency deviation and impact time parameters. The simulation analysis results show that the measurement of transient overvoltage can be realized by the way of C3 partial pressure. The result of the test shows that when a lightning overvoltage is applied to the hybrid CVT, and it cannot be accurately transmitted by the secondary side. The voltage waveform at both ends of C3 does not oscillate significantly. However, the occurrence of similar shock phenomenon, considering the factors that may be derived from the measurement method, such as the influence of the matching impedance of the oscilloscope on the measurement results, further improvements and tests are needed. The above results are still of practical value for designing actual products and optimizing product performance.

## Acknowledgments

This article is one of the phased achievements of Hebei Province's key research and development project" Broadband and Large Dynamic Range Current and

Voltage Measurement Technology Research and Equipment Development for Clean Energy"; The item number is 19212103D; The project leader is Guo Zhizhong; Start and end time 2019.05-2021.12.

## References

1. Yang Jian, Cheng Hanxiang, Yu Yin, Li Lei. Current status and development of voltage transformers in power systems[J]. Electrical Engineering, 2015(07): 6-9+23.
2. Wang Liming, Fang Bin. Simulation of transient characteristics of 500kV capacitive voltage transformer[J]. High Voltage Technology, 2012, 38(09):2389-2396.
3. Yang Gang, Ran Zifeng, Arts, Yan Zheng, Li Jianming. Verification of Transient Characteristics of Capacitor Voltage Transformer[J].Sichuan Electric Power Technology,2013,36(06):87-91.
4. Xie Zenan, Zhao Wenbin, Zhao Dandan. Improved transient overvoltage monitoring and transient component extraction method[J]. Water Power Energy Science,2020,38(06):196-200.
5. Wen Yi, Chen Shaoqing. Research on CVT transient overvoltage response [J]. Power Capacitor and Reactive Power Compensation, 2014, 35(01): 45-50+59.