

Control modules in the "Intelligent building" system

*Andrey Alyoshintsev, Natalia Mokrova, and Alexander Sak**

Moscow State University of Civil Engineering, Yaroslavskoe shosse, 26, Moscow, 129337, Russia

Abstract. The relevance of the article consists on the use of telemetry control modules to organize the uninterrupted operation for dispatching service, including remote work. Thanks to telemetric means of dispatching control and management of the conditions of water supply facilities, the process is reaching a new qualitative level. The functionality of the water intake unit has been significantly improved as a result of the introduction of a telemetry and telecontrol system in the form of separate technological modules. The developed modules provide additional functions for water quality control, including residual chlorine, accounting for a number of random pollution factors in addition to the route technology of the dispatching system; remote control of executive mechanisms with the possibility of automatic control; self-diagnostics of the software and hardware complex, as well as planning of preventive and repair work of engineering systems. The results of water quality on-line monitoring by using a telemetry module in the chlorination room automatically providing the optimal ratio of chlorine added to the water are presented.

1 Introduction

An intelligent building (IB) is a system of design, organizational, engineering, technical and software solutions that provide a flexible and efficient technology for servicing a building that meets the needs of the XXI century, in compliance with modern technologies. [1]

Water Quality Monitoring (WQM) is a cost-effective and efficient system designed to monitor drinking water quality which makes use of Internet of Things (IoT) technology. In this paper, the proposed system consists of several sensors to measure various parameters such as pH-value, the turbidity of the water, level of water in the tank, temperature and humidity of the surrounding atmosphere. Also the Microcontroller Unit (MCU) is interfaced with these sensors and further processing is performed at Personal Computer (PC). [14]

Modules automate the work of the station, by reducing the number of accidents at sites and by increasing work efficiency.

Research and analysis of existing life support systems of IB is relevant, since the system achieves:

*Corresponding author: sakan@mgsu.ru

- the ability to control and automatically regulate complex life support networks, consisting of many parts;
- ensuring the operability of this system in the specified modes of the environment;
- providing functional dependence of individual parts of the system on each other;
- ensuring the maximum possible use of third-party (various) resources, for example, in alternative energy, using reference sets (packages) of parameters. [7]

The control of the flow rate of the liquid entering the control and measuring tank using various flow meters, as well as the control of the liquid supply and the regulator is detailed in the source [2]

When creating automated dispatch control and management systems, great importance is paid to water quality, for example, such an issue as electro hydro-impulse cleaning of hot and cold water supply systems, radiators and boilers. [4]

In dispatching, a lot of basic actions that are the implementation of technological processing operations are well known. They are determined by the range of manufactured products and their routing technology. In turn, the set of auxiliary actions is not known in advance and depends on a number of factors associated with the main actions and resources of computer-integrated production. [6]

2 Methods

2.1. Automated system of dispatch control and management

ASDCM WIU (water intake unit) is intended for collecting, processing, archiving and transmitting data to the central dispatching point (DP) of information about the parameters of operating modes and the state of energy metering devices and engineering systems of the VCU facility.

The dispatch service controls the continuity of supply with the elimination of accidents while providing water supply, sewerage, power supply to the "IB" facilities.

Many works have been devoted to the control and distribution of water supply in the city, for example (the city of Santiago de Chile [11], the city of Barcelona-Spain [12])

2.2 The dosing system of the automated series ASDGN for disinfection of drinking water

Chlorination is a common disinfection method in water treatment. This method can be converted into an advanced oxidation process by incorporating UV irradiation during water treatment. [8]

The use of the Automated System for Dosing Sodium Hypochlorite (ASDSN) made it possible to organize a local control room (LCR) with a reflection of the disinfection process on a mnemonic diagram of a personal computer monitor in real time.

Dosing complex is a set of equipment responsible for supplying a certain amount of chemical agents at a certain time interval.

The agent dosing complex has the main task of automatically measuring the required amount of reagent, which should be used for water purification, using chemical reagents.

Many of these installations consist of several mandatory metering pumps that are metering (which task is to introduce the exact amount of reagent into the water) and control units (control the operation of the entire system), as well as a metering pump.

These blocks are comprised of automated control slots. They have a user-friendly interface, thanks to which the necessary parameters are configured and set conveniently and easily. The required settings must be specified during the installation of the system, but sometimes they need to be adjusted. Such possibilities for adjusting the set parameters, if necessary, are provided in the control unit.

The system is designed for reliable and prolonged disinfection of water obtained from artesian wells and fed further into the distribution network.

The basis of the disinfection process is the working dose of active chlorine, which ensures the proper bactericidal effect of the destruction of *E. coli* in the treated water during the contact period of chlorine with water.

In drinking water treatment plants generally chlorination is applied for disinfection using Cl_2 , ClO_2 , or NaOCl reagents. [9]

Determination of the working dose is regulated by the instructions; the frequency of determining the working dose is regulated by the state standard. The time of the contact period, after which the residual chlorine is determined, is regulated by sanitary rules and regulations.

The working dose of active chlorine (D) is defined as the ratio of active chlorine (KCL), gr. to the flow rate (volume) of incoming water (P), m^2 :

$$D = KCL/P \quad (1)$$

Hence, the required amount of active chlorine is determined by the ratio:

$$KCL = D \cdot P \quad (2)$$

In this formula, D is a constant value for a certain period. P is the value to be determined by the flow meter. Formula (2) clearly and unambiguously dictates the scheme for constructing the technological process of chlorine disinfection (see Fig. 1.) which allows normalizing the contact of water with chlorine.

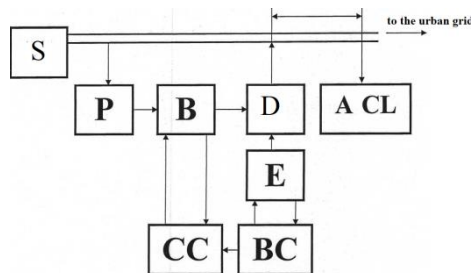

Fig. 1. Block diagram of the de-freezing process

where S is the source of water; P - water flow meter; B - calculator that determines the value of KCL ; D is a dosing device that executes the command of the calculator and directs the specified KCL into the pipeline;

E is a reagent storage capacity; BC is device that determines the actual consumption KCL ; CC is a diagram for comparing the set and actual flow rate KCL ;

$A CL$ is a residual chlorine analyzer (or titration).

2.3. Complex work.

The equipment of the system (see Figure 2) is dispersed on the territory of the water pumping station (WPS). The objects located on the territory of the WPS, where the equipment of the complex is installed, include:

- directly at the WPS station, a personal computer (PC), flow meters are installed, which determine the flow of water into the PWR from wells.
- pure water reservoir (PWR), with a built-in level gauge to determine the water level in the reservoir.
- room for dosing sodium hypochlorite, where, in accordance with the technological

scheme, sodium hypochlorite is stored and supplied in certain portions to the pipelines supplying water to the CWR.

- chambers on the inlet pipelines, in which the injection nozzles are mounted, through which sodium hypochlorite is dosed.

The equipment operates in the following sequence (Fig. 2). From the transport tank, sodium hypochlorite (HH) is pumped into the storage tank (1). From the storage tank, sodium hypochlorite is pumped into the supply tanks (4) installed on the scales by pumps (2).

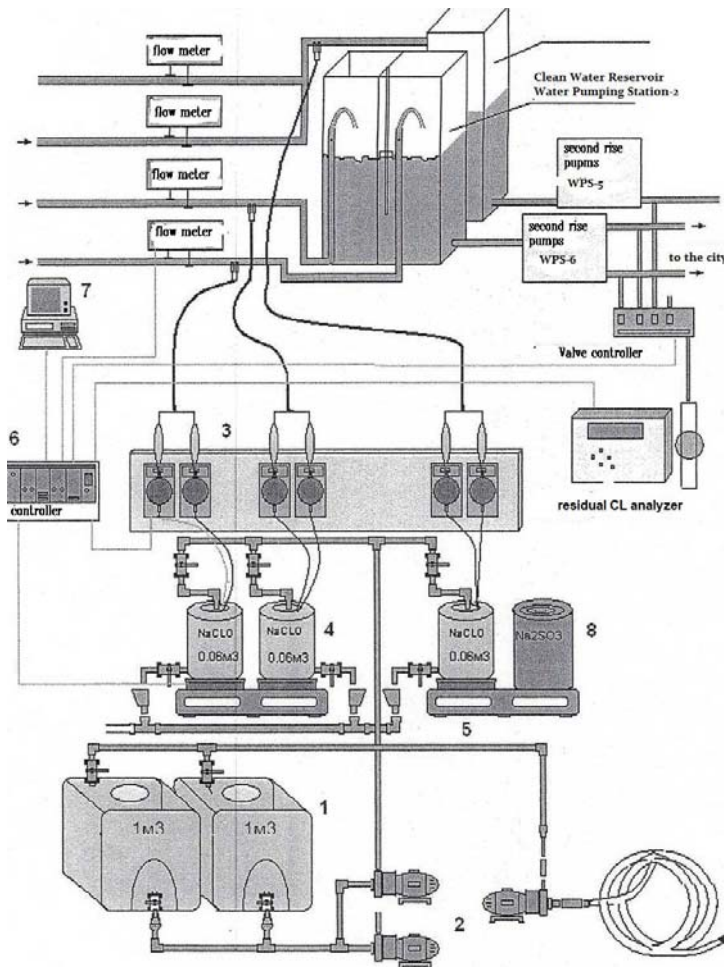

Fig. 2. Flow diagram of the sodium hypochlorite dosing complex at the WPS

Consumable containers are ready for use. Dosing pumps (3), under the control of a computer and a controller, pump sodium hypochlorite from each of its containers into the pipeline supplying water to the PWR. Two metering pumps are installed on each LP supply line.

To maintain the LH supply lines in working order, the metering pumps are periodically switched over. Switching them occurs after the expiration of the time set in the "Settings"

menu.

The rest of the time, the dosing process is automatic. Each consumable container is located on an electronic scale.

The balance continuously monitors the amount of sodium hypochlorite in grams supplied to the pipelines and sends this information to the controller, and from there to the personal computer.

The dosing pumps operate on commands from the controller. Dosing pumps duplicate each other in case of failure of one of them. The lines for supplying sodium hypochlorite to the pipelines and injection nozzles are also duplicated.

2.4 . Calculation of the required amount of sodium hypochlorite

The process of calculating the required amount of sodium hypochlorite supplied to the pipelines occurs cyclically for a selected period of time in minutes. The time period (cycle) is selected by the operator and set in the “Setup” menu. The amount of sodium hypochlorite injected per cycle into each pipe is provided by the number of strokes of the dosing pumps determined by the following formula:

$$P_s = (WD \cdot WF \cdot K_x \cdot 1000) / MCH \cdot DPC \tag{3}$$

where K_x is the number of pump strokes, WD is the working dose, mg / l, WF is the flow of water, cubic meters. m / cycle (according to the readings of the flow meter), MCH is the mass number of active chlorine in one liter of sodium hypochlorite, g / l, DPC is the dispenser pump capacity, ml / stroke.

The capacity of the metering pumps is determined by a special program and is systematically displayed on the monitor, which allows you to make the appropriate adjustments through the “Settings” menu. The program provides for the determination of the actual working dose of the disinfection process. The actual working dose (AWD) is determined by the formula:

$$AWD = (Weight \cdot MP) / 1.25 \cdot Ch \cdot PVCH \cdot 1000 \tag{4}$$

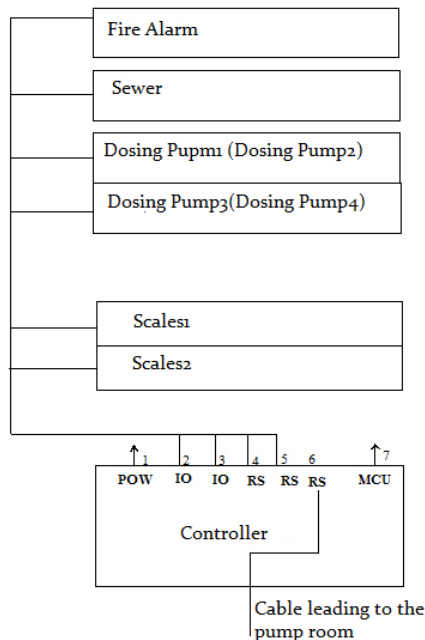

Fig. 3. Dispensing module

where Weight G_{Nch} is the change in the readings of the weights for the adopted cycle in grams, MP is the mass number of sodium hypochlorite, (g / l), $P V c h$ is the flow of water, m^2 . meters / cycle.

Difference AWD minus residual chlorine represents chlorine uptake, in mg / L. Residual chlorine is determined by titration. Chlorine absorption for water from wells is permanent and temporary.

Thus, AWD determines the amount of residual chlorine, and its stable maintenance guarantees stable maintenance of residual chlorine. To adjust the working dose, the so-called technological factor (TF) has been introduced into the setting, which allows you to correct it within small limits.

2.5. Automatic control of the complex

The control system of the complex consists of the following blocks:

- Personal Computer,
- dosing controller,
- secondary measuring transducers of scales,
- control unit for pumps HCM and ventilation,
- cabinet for coordination with power supply and stabilization units.

The approximate composition of the dispensing module is shown in Fig. 3.

The controller (Fig. 4) consists of a set of modules. The controller modules are controlled by the MCU (M) module, there is a control program embedded in it, and a debug computer is connected to it (if necessary) via the DB-9 RS-232 connector.

The 2-RS module receives signals from the flow meter about the amount of incoming water, 4- RS communication with a personal computer via the RS-485 channel.

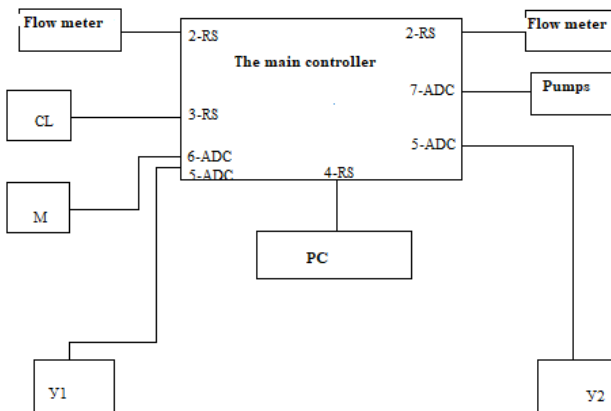

Fig. 4. An example of devices connected to the main Water Intake Unit controller

The PC is installed in the IPS operator station.

The metering room contains the instruments and equipment of the complex: controller, metering pumps, secondary measuring transducers of scales, a cabinet for matching with power supplies, pump control units and an automatic power supply.

The controller is designed to receive signals from devices and sensors, process them, communicate with a PC and issue control signals to dosing pumps.

The methodology presented here is based on a sequence of tests and on the combined use of spatial models (SM) and time series models (TSM) applied to the sensors used for real-time monitoring and control of the water network. Spatial models are based on the

physical relations between different variables of the system (e.g. flow and level sensors in hydraulic systems) while time series models are based on the temporal redundancy of the measured variables (here on the basis of a Holt–Winters (HW) time series model [13].

All existing networks are protocol built according to the "Master - Slave" principle.

The controllers include several measuring channels that collect information from primary sensors, convert and transmit it to the Control Center (CP), as well as broadcast commands from the CP to the actuators. Communication is carried out via a dedicated physical line, a radio channel, a switched channel of a city automatic telephone exchange, a mobile communication channel, etc.

The complex is automatically controlled by a controller and a PC.

Water meters are installed on the pipeline. Signals from flow meters measuring the volume of incoming water are continuously fed to the controller and PC.

2. 6. Embedded module.

Chlorination module.

Chlorination of water is a preventative measure to prevent organic deposits. Its duration and the intervals between cycles depend on the number of microorganisms in the water and their resistance to chlorine. Chlorination is carried out with gaseous chlorine. Chlorination of water ensures a decrease in biological contamination not only of condensers, but also of all apparatus and pipelines of the technical water supply path. At relatively low costs, bleach is used for the chlorination of water. [10]

To ensure the optimal ratio of chlorine entering the water, a module has been introduced into the chlorination room. Thanks to this, the water purification process is automated. The following is a developed piece of code, thanks to which the module performs its work.

3 Results

Chlorinated code snippet

```

;*****
; Chlorine sensor query
;*****
;a query to Depolox
3500 ON J1 GOTO 3510,3600,3520,3700;, C2

;Request frame
;      SYN   SB SA ZA KB AB FC EB
;synchronization bytes SUN
;start byte -SB -10H - request frame
;slave address -SA - 0 –the free chlorine meter
;destination to the address ZA
;checking out byte KB (0 - 3 bit 0000 DEFAULT TO ADDRESS REFERENCE LIST)
;      (7 - 5 bit 0000 the actual value is written or read ;number of bytes - AB 00
;content of a dist address are requested
;frame check FC =SB+SA+ZA+KB+AB(without taking the shift in consideration )
;END BYTE - 16H
3510 I2C#A2,(19H)=0H,0H,0H,10H,0H,4H,0H,0H,14H,16H:J1=1:GOTO 3990;

```

```
;J1=2
; Enquiring the state of relay and digital entries
3520 I2C#A2,(19H)=0H,0H,0H,10H,0H,0AH,0H,0H,1AH,16H:J1=3:GOTO 3990;
```

```
;F11 – word determining the state of relay
;7 6 5 4 3 2 1 0
;      1 an error of control sum of an snapshot
;      1 there is a connection
;      1 an error of control sum od data
;      1 no connection
;      1 no connection with controller
```

```
*****
```

```
;Chlorine sensor data processing
```

```
*****
```

```
3600 MEM(MA+20)=0:MEM(MA+9)=0:MEM(MA+10)=0; reduction to zero
3601 S1=I2C#A2,(4EH):A=I2CA:IF A=1 THEN F11=16:X4=0:GOTO 3630;
3602 IF S1=0 THEN F11=8:X4=0:GOTO 3630;Obtaining zero result
```

```
3605 FOR I3=0 TO 22 ;N1-1
3606 MEM(MA+I3)=I2C#A2,(1AH) ;:PHB mem(MA+I),
3607 NEXT I3
```

```
-----
;Control sum of data
```

```
3620 S1=0
3621 FOR I3=0 TO 11
3622 S1=S1+MEM(MA+9+I3)
3623 NEXT I3
3624 S1=S1.AND.0FFH: IF S1 <> TMP THEN F11=4: GOTO 3640;further
3625 F11=2 ;OK!
```

```
3630 S1=MEM(MA+20); ? "Division - ",Y ;divider
3631 X1=MEM(MA+9)*256+MEM(MA+10);
3632 IF S1>0 THEN X1=X1/S1 ELSE X1=0;
3633 IF X1>99 THEN X1=99;
3634 X4=X1:PRINT "Total CL - ",X1;
3635 ON I1 GOTO 3636,3637,3638,3640,3640;
3636 IF F0=1 THEN X5=X4:GOTO 3640
3637 IF F0=1 THEN X6=X4:GOTO 3640
3638 IF F0=1 THEN X7=X4
```

```
;No coincidence of KC obtained from chlorine sensor
;A2is a controller of remaining chlorine sensor DEPOLOX 3 plus
;just in case deleting all data connected to data gathering
; resetting the buffer of obtained data and readiness flag deleting
3640 I2C#A2,(4AH)=0C0h:I2C#A2,(4BH)=0C0h:I2C#A2,(5EH)=0
; deleting the counter of received bytes and errors flag
3641 I2C#A2,(4EH)=0: I2C#A2,(4FH)=0
:deleting overflow flag
3642 I2C#A2,(41H)=0:J1=2:GOTO 3990;
```

;J1=3-state of relay and digital entries

```
3700 S1=I2C#A2,(4EH):A=I2CA:IF A=1 THEN F11=16:X2=0:X3=0:GOTO 3740;
3702 IF S1=0 THEN F11=8:X2=0:X3=0:GOTO 3740;
```

```
3705 FOR I3=0 TO S1-1 ;N1-1
3706 MEM(MA+I3)=I2C#A2,(1AH);:PHB mem(MA+I3),
3707 NEXT I3
```

;the control sum of data

```
3720 S1=0
3721 FOR I3=0 TO 1
3722 S1=S1+MEM(MA+9+I3)
3723 NEXT I3
3724 S1=S1.AND.0FFH: IF S1 <> TMP THEN F11=4: GOTO 3740;further
3725 F11=2 ;OK!
```

```
3730 X2=MEM(MA+9);the first byte of data
3733 X3=MEM(MA+10);the second byte of data
```

4 Discussion

Automation of the reagent dosage processes helps to reduce their consumption, improve the quality of water after treatment and facilitate the work of the service personnel. [3]

When processing drinking water, automation of control of such processes as dosing of reagents, mixing reagents with water, regulation of the filtration rate, chlorination, ammonization and ozonation of water are absolutely necessary, since with manual control the required accuracy of these processes is essentially impossible. [5]

The module automates the work of the station. Reducing the number of accidents at facilities, increasing the efficiency of work, and most importantly, water is purified better. Providing the equipment with new devices, thanks to telemechanics, the following actions are possible: automatic monitoring, warning signaling, collection of resource accounting information, diagnostics of communication channels.

5 Conclusions

The implemented telemetry modules allow automating the work of the station. As a result, to reduce the number of accidents at facilities, to increase work efficiency, and most importantly, water is purified much better. Each controller in the module is configured for a specific task, which makes the system the most optimal, because it is formed taking into account the specific state of the decontamination system. And the use of the proposed method for monitoring and transmitting data allows continuous diagnostics of communication channels, the operability of all systems, and there is no need to send specialists directly to the object every time: parameterization and calibration of devices is carried out remotely. Quick setting of limit levels and operating modes makes it possible to flexibly manage the production process, reconfigure it according to changing tasks. In addition, refurbishment work is underway.

References

1. A.V. Alyoshintsev, P.A. Kholodkov, *Overview of the main technologies used in the construction of the "Intelligent building"* in T-Comm: Telecommunications and

- transport, Special issue following the results of the 3rd branch STC "Technologies of the Information Society", LLC "ID Media Publisher", (Part-2), No. S2. 2009, Moscow, Russia(2009)
2. M. A. Kornipaev, A. I. Sergeev, L. V. Galina, D. A. Proskurin, *Automatic control of flow rate, pressure and liquid level: textbook* in Orenburg State University, EBS ASV, Orenburg , Russia (2016)
 3. E.E. Arkhipova, D.S. Aleshko, E.V. Dunaevskaya, Application of new water treatment technologies within the framework of the project "Expansion and reconstruction of the water supply system in the city of Khabarovsk (second stage) in Water purification. Water treatment. Water supply. 2018. No. 3 (123), Moscow, Russia, (2018)
 4. A.R. Denisova, D.Yu. Panov, *Research on energy efficient measures in municipal institutions* in Innovations in science and practice. Collection of articles based on the materials of the VIII international scientific and practical conference. In 5 parts. 2018. pp. 57-60., Moscow, Russia, (2018)
 5. Yu.V. Bolotova, O.I. Ruchkinova, The main problems of the water management complex (VHK) of Russia and their solution by means of computer technology, with the help of automation and dispatching in Bulletin of the Perm National Research Polytechnic University. Electrical engineering, information technology, control systems. 2016. No. 19, Perm, Russia, (2016)
 6. V.V. Vasetsky., V.M. Pitolin, *Approaches to Algorithmization of Dispatch Control in Production Systems* in Bulletin of the Voronezh State Technical University. 2012. T. 8.No. 1, Voronezh, Russia (2012)
 7. I.G. Panyaev, The automation system of the life support networks of multi-level facilities and the way the automation system works / Patent for invention RU 2701962 C1, 02.10.2019. Application No. 2018130810 dated from 08.24.2018.
 8. Nur Adawiyah Mansor, Kheng SooTay, *Potential toxic effects of chlorination and UV / chlorination in the treatment of hydrochlorothiazide in the water* in Science of The Total Environment. Volume 714, 20 April 2020 DOI: 10.1016 / j.scitotenv.2020.136745
 9. Dávid Stefán, Norbert Erdélyi, Bálint Izsák, Gyula Zaray, Márta Vargha, *Formation of chlorination by-products in drinking water treatment plants using breakpoint chlorination* in Microchemical Journal. Volume 149, September 2019, DOI: 10.1016 / j.microc.2019.104008
 10. V.N. Dvorovenko, Elimination of emergency modes of powerful steam turbine plants. In K., "Tekhnika", 1979.
 11. G. Cembrano, J. Quevedo, V. Puig, ..., H. König, *First results of predictive control application on water supply and distribution in Santiago-Chile* in IFAC Proceedings Volumes, Volume 38, Issue 1,2005, Pages 25-30. <https://doi.org/10.3182/20050703-6-CZ-1902.02175>
 12. J. Quevedo, V. Puig, G. Cembrano, J. Blanch, J. Aguilar, D. Saporita, G. Benito, M. Hedro, A. Molina *Validation and reconstruction of flow meter data in the Barcelona water distribution network* in Control Engineering Practice Volume 18, Issue 6, June 2010, pp. 640-651
 13. A. Miquel, Diego García Cugueró-Escofet, Jaume Roquet, A methodology and a software tool for sensor data validation / reconstruction: Application to the Catalonia regional water network in Control Engineering Practice, Volume 49, April 2016, pp. 159-172 <https://doi.org/10.1016/j.conengprac.2015.11.005>
 14. Sathish Pasika, Sai Teja Gandla, *Smart water quality monitoring system with cost-effective using IoT* in Heliyon, Volume 6, Issue 7, July 2020, Article e04096 <https://doi.org/10.1016/j.heliyon.2020.e04096>