

Autonomous complex for electro-thermal heating of oil wells fed by a photovoltaic installation

Y.E.Shklyarskiy, V.V.Starshaya

¹Department of General Engineering, Saint Petersburg Mining University, Saint Petersburg, Russia

Abstract: Paraffin deposits are a serious problem causing complications in oil production. This article describes the creation of a complex operating on photovoltaic installations to combat paraffin deposits. The authors offer an innovative method for accurate calculation of the parameters of photovoltaic installations, taking into account changes in total solar radiation, geographical and climatic conditions, the angle of inclination of solar panels, characteristics of the power source, and oil parameters. Measurements of solar radiation are carried out on the basis of mathematical and simulation modeling in Matlab Simulink. The results of the studies confirm the adequacy of the proposed method of oil well heating. This method of electric heating has a simple design and does not require underground works and well shutdown. Thus, it will improve the efficiency of oil production, prevent the formation of paraffin deposits, and ensure energy savings by reducing power losses and electricity consumption.

1 Introduction

One of the five key challenges facing the global oil industry is the increase in production costs due to the prevalence of hard-to-recover reserves and high degree of field depletion. This makes it difficult to maintain the achieved levels of oil production and necessitates the use of expensive technologies to increase the production rate of wells [1,2]. In this regard, the commissioning of small deposits will become increasingly important. Their reserves are estimated at 1 million tons. But their share is up to 12% of the total hydrocarbon reserves in the traditional energy sector of Russia [3]. Approaches to the development of such deposits differ from traditional deposits. Development of new fields becomes limited due to the remoteness of oil production sites from the centralized power supply system.

One of the biggest problems in oil production, which causes serious complications in the operation of wells and oilfield equipment and pipeline communications, is the formation of paraffin deposits [4].

Formation of paraffin deposits leads to a decrease in the cross-sectional area of pipes, an increase in resistance to fluid flow and movement of the rod string (for sucker rod pumping units), an increase in the loads on oilfield equipment, a reduction in the tubing throughput diameter, an increase in hydraulic resistance, a decrease in the performance efficiency of the pump units and a decrease in the production rate of oil wells [5]. Besides,

the formation of paraffin deposits increases the risk of oil spills and causes substantial problems, including the following [6]:

- Stoppage of oil production process.
- Reduction of system performance and pumping unit efficiency.
- Increased costs of oil production.
- Reduction of the period between overhauls.

Currently, many existing methods can only increase the time between repairs run of the equipment; moreover, they have a number of other disadvantages [7]:

- Mechanical methods cannot be used to clean the bottomhole zone of the well due to the design features of the scrapers used.

- Chemical reagents and paraffin solvents are recommended for use only as an additional means of combating deposits and have a high fire hazard.

- Special coatings for tubing are a preventive method, but do not exclude the formation of paraffin.

- Magnetic and acoustic methods are ineffective at high concentrations of paraffin (more than 20%).

Today, the most efficient methods of controlling the formation of paraffin deposits in tubing are thermal methods for providing thermal effect on the wellbore, based on the ability of paraffin deposits not to form a solid phase or melt at temperatures exceeding the paraffin crystallization temperature of 35-50°C [8]. However, the remoteness of production sites from the centralized power supply system complicates the task of effective use of electrothermal technologies for thermal treatment to combat paraffin deposits and increase the efficiency of hard-to-reach oil production.

Diesel generator installations are used to solve the problems of power supply for oil and gas production. Also, mobile steam generating units can be used. They also operate on diesel and are housed in a truck. They are used for periodic thermal treatment of the wellbore with water steam at temperatures up to 300° C and injection pressure up to 10 MPa. The operation of a diesel generator installation and the operation of a mobile steam generator installation is carried out due to the combustion of hydrocarbon fuels, which significantly harms the environment. There is an increased risk of soil contamination from spills during transportation, storage, and refueling with diesel fuel and oils. The air is polluted by exhaust gases and large amounts of carbon dioxide are produced.

The introduction of an autonomous electrothermal heating system powered by renewable energy sources will simultaneously:

1. Increase the efficiency of oil production in new hard-to-reach fields, including small fields remote from the centralized energy system.
2. Prevent the formation of paraffin deposits through periodic electrical heating of oil wells.
3. Increase the energy efficiency and reliability of the power supply of the source of electrothermal exposure.
4. Ensure energy savings by reducing power losses and electricity consumption.

The study examined two rapidly growing renewable energy sources. These are solar and wind energy (Belsky et al., 2016). Despite the growing share of wind energy and a high potential for its use in Russia, solar energy has been selected as the source of power supply. The main advantage of solar power plants for heating of oil wells is the direct current operation. The use of solar energy will help greatly to exhort the design and reduce the cost of the system implementation due to the simplicity of the design no requiring any additional inverters. Besides, the cost of fasteners and mounting elements for solar panels is lower than for a wind generator. Therefore, it is cheaper and more efficient to use solar energy for this load.

From the analysis of the Russian solar power industry, it was found that about half of the

territory of the country, that is not covered by the centralized powersupply system(PSS),is located in regions with high potential for using solar power [9]. Based on the analysis ofthepotential for the use of solar power in Russia, near the oil fields, located far from the centralized power supply system, an autonomous complex ofelectro-thermal heating of oil wells powered by a photovoltaic plant was chosen as the power source for the heating cable, providing a thermal effect on the well.

The work of Kovrigin [10] and Obaseki [11] confirm, that the thermal paraffin removal method is the most effective, but a careful cable power calculation is necessary. . Usually, the cable is turned on to high power, which leads to unnecessary energy costs and frequent cable breakdowns, i.e., insulation breakdown. Besides, based on the literature review, there is no work that suggests using a photovoltaic installation as a power source for a heating cable. When choosing the capacity of the complex, we take into account the parameters of oil, the heat-and-power characteristics of the cable, and the change in solar insolation. Thus, we contribute to the existing literature with the idea of using solar energy as a power source for a heating cable, and we also calculate the exact value of the power required for heating.

This way, the scientific novelty of the article is as follows:

1. Regularities that characterize the processes of power consumption in the system of autonomous power supply for electric heating of oil wells, based on the parameters of the characteristics of solar batteries, taking into account meteorological data are revealed.

2. The choice of the composition and parameters of theelectrical complex was carried out on the basis of the parameters of the power consumption of the electric heating cable, geographical and climatic conditions, including the average and maximum values of the solar radiation flux density, the frequency of their occurrence, the characteristic features of removal and prevention of formation of paraffin deposits.

Thus, the purpose of the work is to develop an autonomous power supply system powered by a photovoltaic station to remove paraffin deposits in oil.To achieve this goal, it is necessary to perform the following tasks:

1. To assess the potential of using renewable energy sources (solar energy) in the oil-producing provinces of the Russian Federation.

2. To carry out mathematical modeling of changes in the total solar radiation, taking into account the limited amount of meteorological data.

3. To determine the heat and power characteristics of the electric heating source, taking into account the depth of the formation, the daily flow rate of the well, and the degree of paraffin deposits in oil.

4. To develop a computer simulation model of an electrothermal heating system powered by a PMT in Matlab Simulink for verification of mathematical measurements.

5. To determine and substantiate the structure and parameters of the electrothermal heating system with small photovoltaic units for guaranteed power supply to consumers.

2 Initial data

The oil field of the Astrakhan region was selected as the study field. The field area is about 800 sq km. Approximate reserves of the field are about 300 million tons of oil and 90 billion cubic meters of gas, the depth of which varies from 2 to 5 km. Of these, recoverable reserves amount to 42.3 million tons. Physico-chemical characteristics of oil are presented in Table 1. Composition of paraffin deposits: asphaltenes - 2.11%, resins - 10.20%, paraffins - 6.55%.

Table 1. Characteristics of oil deposits.

Type of characteristic	Value
Well length, m	2700
Well angle, degrees	9

Concentration of paraffin, %				4 (8)
Flow rate of the well, t/day	25	50	75	100
Inner diameter of the pipe, mm	50.3	50.3	62.0	62.0
Water cut of extracted products, %				10
Density of the produced products, kg/m				840
Specific heat of the product, J/(kg·°C)				2300
Gas to oil ratio, m ³ /m ³				29.2
Reservoir temperature, °C				75
Reservoir pressure, MPa				25
Neutral land temperature, °C				11
Depth of the neutral land layer, m				30

3 Methods of research

Methods of the theory of electrical circuits, mathematical simulation, calculation of power supply systems, statistical processing, and analysis of the results of theoretical and experimental data were used in the work [12]. Electric power calculations were performed based on the theory of electrical circuits using numerical analysis in the mathematical package MathCAD [13]. Thermal calculations were carried out taking into account the VNIIneft methods for determining the temperature of oil saturation with paraffin. The method for calculating heat transfer coefficients in the well was developed by prof. S.M. Kuptsov, Dr. of Engineering.

3.1 Modeling of the solar radiation change

The energy characteristics of a solar photovoltaic installation depend on two main factors: the parameters of the photovoltaic battery and the characteristics of its photovoltaic cells; the intensity of the solar radiation flux at a certain location and under specific conditions [14]. To calculate the flux of solar radiation, the method by John A. Duffie [15] is used. It presumes:

1. Calculation of the amount of direct solar radiation I_{dir} , entering arbitrarily oriented Earth's surface at an angle β taking into account the geographic coordinates of a location on a clear (cloudless) day.
2. Calculation of the amount of scattered solar radiation I_{scat} , taking into account the geographic coordinates of a location, as proposed by N.M. Kopylov, on a clear (cloudless) day, correlating the intensity of the scattered radiation with the intensity of the direct radiation [16].
3. Calculation of the amount of reflected solar radiation I_{ref} , taking into account the geographic coordinates of a location on a clear (cloudless) day, considering the albedo ρ (reflectivity) of the Earth's surface.
4. Calculation of total solar radiation, falling on an arbitrarily oriented surface of the Earth on a clear (cloudless) day [16]:

$$\Sigma I = I = I_{dir} + I_{scat} \frac{1 + \cos \beta}{2} + \rho I_{ref} \frac{1 - \cos \beta}{2} \quad (1)$$

The solar radiation flux depends on geographic and climatic conditions, season and the time of day, and the solar battery orientation relative to the solar vector [17]. Climatic changes in a particular geographic location introduce substantial adjustments when assessing the illumination and photoelectric current of the solar battery. In the presence of

clouds, the intensity of irradiance changes depending on their distribution across the sky and their position relative to the orbit of the Sun. These changes occur so rapidly and within such a wide limits, that the radiation intensity values are of a random nature. The amount of solar radiation I_{cloud} , taking into account the coefficient of cloud cover and formula (1), is calculated by the method, proposed by S. I. Sivkov [16]:

$$I_{cloud} = \Sigma I \cdot (1 - 0,38 \cdot K_{cloud}(1 + K_{cloud})), \tag{2}$$

where K_{cloud} - the coefficient of cloud covering (0 - no clouds, 1 - continuous cloud covering), is determined based on the data obtained from weather stations; ΣI is the average annual total solar insolation on an inclined surface, calculated according to the formula by John A. Duffie [15].

The cloud coefficient K is considered as an indicator of an infinitely extended and horizontally uniform cloud layer for each geographic point since the model of the developed complex provides quasi-constant heating, which allows not to consider the properties of layered clouds and the effect of single clouds. Correction of the values of the total solar radiation entering an arbitrarily oriented surface was performed taking into account the law of normal distribution of random quantities, subordinated to the mean value for the period under study.

Figure 1 presents simulation modeling of an autonomous electrical complex in the Matlab Simulink program.

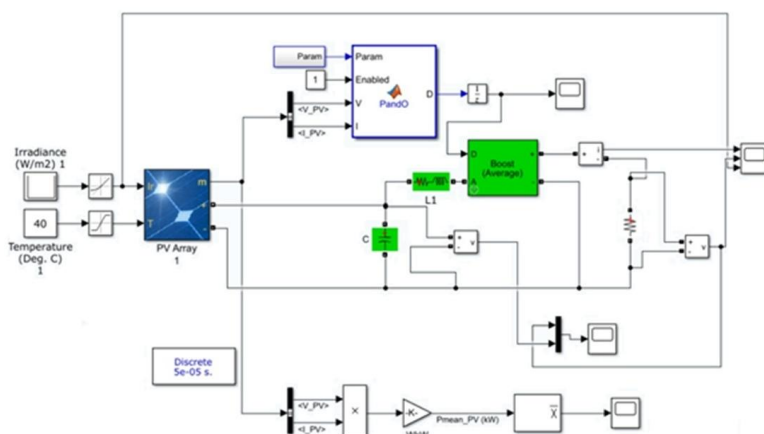

Fig. 1. Simulation modeling in the Matlab Simulink.

This model allows obtaining a graph of the energy characteristics of a photovoltaic installation for any day of the year and any geographic location based on formulas (1) and (2) from the article. The measurements were carried out under standard calculation conditions (solar insolation 1000 W/t2, ambient temperature 25°C). We used the parameters of a 300W monocrystalline solar cell, such as current, voltage, power temperature coefficient, number of cells, number of panels.

Figure 2 presents the results of simulation modeling (energy characteristics) of an autonomous electrical complex in the Matlab Simulink program. The rated power of the photovoltaic installation is the basic value for “power”. The nominal resistance of the source of energy (photovoltaic panel) is the basic value for the “heating element resistance”. The maximum power will be when the heating element resistance is equal to the nominal resistance of the source of energy (the heating element resistance = 1 and power = 1 in conventional units). The graph shows that the power will depend on the resistance. When the resistance increased to 1.5 conventional units, the power decreased to

0.6 conventional units. This is primarily due to the volt-ampere characteristic of the solar panel. The results show that to obtain maximum power, it is necessary to use the control cabinet: a DC/DC converter with MPPT (Maximum Power Point Tracking) algorithm to regulate the parameters of solar panels. With its help, the power will not depend on the heating element resistance and will be maximum (line along the peak of the hill on Figure 2).

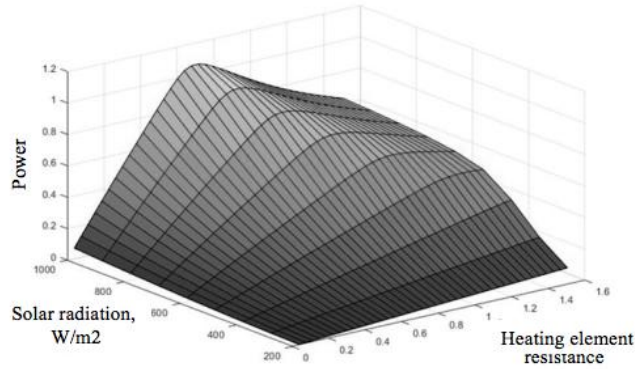

Fig. 2. Energy characteristics in the Matlab Simulink.

To check the validity of the applied mathematical model changing of solar irradiance change, the average annual solar radiation equal to 5.3 kW/m² was calculated using formula (2). Deviation from average annual values of solar insolation, according to NASA weather stations, amounted to 7.5%.

This technique considers the effect of the external climatic factor on the energy characteristics of the solar battery, thereby increasing the accuracy of forecast calculations in terms of power generation for the region under consideration.

3.2 Determining the paraffin saturation point for oil

To determine the paraffin saturation point for oil, the formula, recommended by the All-Russian Institute for Oil and Gas Research (VNIINEFT) is used [7,18]:

$$t = t_0 + 0.2 \cdot P - 0.1 \cdot G, \tag{3}$$

$$t_0 = 11.4 + 34.1 \cdot \lg C_p, \tag{4}$$

where t = the paraffin saturation point for oil under the reservoir conditions (K); t_0 = the paraffin saturation point for oil under the surface conditions (°C); P = the formation pressure (MPa); G = gas to oil ratio (m³/m³); C_p = paraffin concentration in oil (%).

Based on formulas (3) and (4), the paraffin saturation point for oil with average (4%) and high (8%) paraffin concentrations will be $t_{4\%} = 33.1^\circ\text{C}$ and $t_{8\%} = 42.2^\circ\text{C}$, respectively.

Mass paraffin dropout begins in the well at a depth corresponding to the temperature of paraffin crystallization initial point. Within the subsequent interval, a massive formation of paraffin takes place, while closer to the wellhead and in the onshore pipelines deposits in the form of resins occur.

3.3 Temperature distribution over the well depth

The equation for the distribution of oil temperature in the section of the wellbore of a production well with a length of x from the bottom of the well is determined by the formula:

$$t = \theta_0 + \frac{G+m}{A} (1 - e^{-A \cdot x}) + (t_3 - \theta_0) \cdot e^{-A \cdot x} - G [H \cdot (e^{-A \cdot x} - 1) + x] - D_h \cdot (p_3 \cdot e^{-A \cdot x} - p) + \frac{g}{A \cdot c_p} (e^{-A \cdot x} - 1) - \frac{1}{2 \cdot c_p} (w_3^2 \cdot e^{-A \cdot x} - w^2), \tag{5}$$

where θ_0 = the temperature of the neutral layer of the Earth, 11; G = the geothermal gradient; m = a dimensional complex, $m = \frac{q_l}{G \cdot c_p}$;

A = the dimensional complex, which is the main element of the parameter by V.G. Shukhov, $1/m$; $A = \frac{\pi \cdot d \cdot k}{G \cdot c_p}$,

where k is the coefficient of heat transfer from the fluid to rock, W/(m²·K); G - the mass fluid flow rate (liquid rate), kg/s; d = the diameter of the lifting device, m; x = the distance from the bottomhole to the depth, m; D_h = Joule-Thomson coefficient, K/MPa (D - 0.5 K/MPa); p - the bottom-hole pressure, MPa; c_p - the specific heat capacity, J/(kg·K); w - the velocity of oil, $w = 1$ m/s.

Calculation of the temperature of the produced fluid along the wellbore from the bottom-hole to the wellhead is extremely difficult since the temperature values fall under the dependencies for determining the number of fluid properties (viscosity, density). This fact, in its turn, affects changes in pressure and velocity. To ensure the accuracy of temperature determination, it is necessary to divide the entire interval from the bottomhole to the wellhead into separate sections within which the properties of the fluid can be assumed unchanged. Figure 3 presents a diagram for temperature distribution over the depth of the well using formula (5).

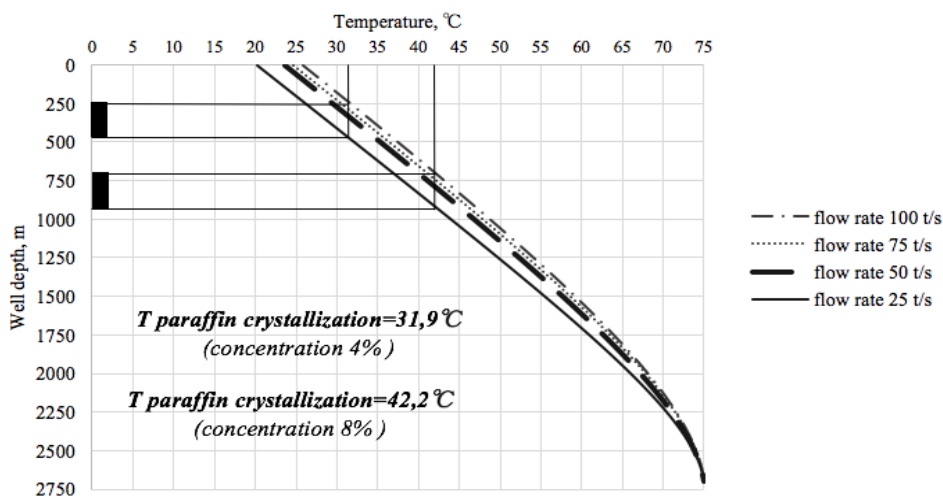

Fig. 3. Temperature distribution over the depth of the well.

As a result of the calculations, it can be concluded that the heating cable must be lowered to a depth of 250 to 900 m, depending on the production rate of the well and concentration of paraffin deposits.

4 Results and discussion

An important task is to substantiate the structure and parameters of the electrotechnical complex with a photovoltaic installation to increase the reliability and economic feasibility of the mineral resources sector facilities' power supply.

4.1 Scheme of the electrothermal complex

The oil well is heated by means of a heating cable placed directly in the inner space of the tubing in the oil well, which allows to heat the wells to the required depth. This scheme of electric heating implementation does not require underground work, and in some cases does not require shutting down the wells. Our task is to ensure the power supply of the heating cable through the development of a power source based on a photovoltaic installation.

The scheme of the complex with a photovoltaic installation is shown in Figure 4.

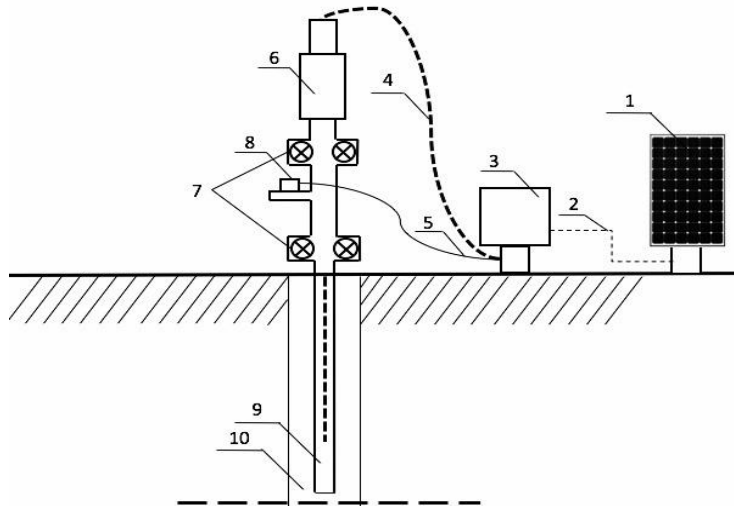

Fig. 4. Composition of the electric heating well complex.

The complex includes 1 - photovoltaic installation, 2 - DC cable, 3 - control cabinet, 4 - heating cable, 5 - cable from the temperature sensor, 6 - wellhead gland, 7 - shutoff valves, 8 - temperature sensor, 9 - tubing, 10 - well. The scheme of the complex is similar to the one previously proposed by [7,18], but is adapted for the use of another renewable source, namely, solar power. In this case, the photovoltaic-based complex operates in a quasi-periodic mode, as in the case of using a wind power plant [7,18]. This mode allows for a thermal effect on paraffin deposits.

4.2 Parameters of the electrical complex

To power the heating cable is assumed to use photovoltaic solar energy converters with a nominal capacity of 300 W at a solar constant of 1000 W/m^2 ; type and composition of cells - single-crystal silicon; the efficiency of the solar panel is 22%. The angle of inclination of solar panels is selected with the account of the uniform generation of solar energy throughout the year and is 60 degrees with an average amount of energy of $5.3 \text{ kWh/m}^2/\text{day}$.

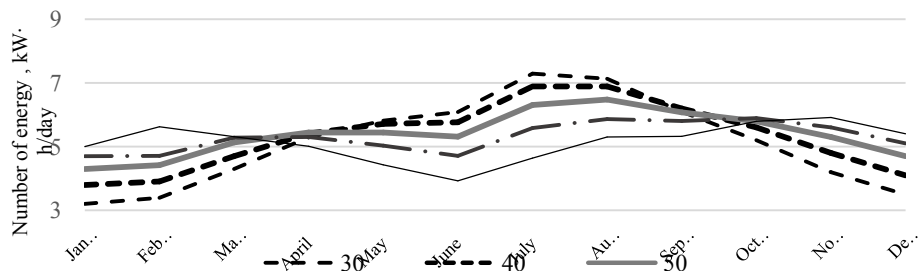

Fig. 5. Choosing the angle of inclination of solar panels.

To provide heating of paraffin deposits, the required power of the solar power plant will be determined by the formula (6):

$$P_{spp} = 1,2 \cdot \frac{Q \cdot P_{sb}}{I_{cloud} \cdot S \cdot \eta_{sb}} \cdot 100\%, \tag{6}$$

where P_{SPP} - the installed power of the SPP (MW); Q - the estimated power of the heating cable (kWh), previously proposed in the article by A.A. Belsky. P_{sb} - installed power of one solar battery, kW; S - the area of the solar panel, m^2 ; η_{sb} - the efficiency of the solar panel, %.

The parameters of the electrothermal complex with a photovoltaic unit are presented in Table 2.

Table 2. Parameters of the electrothermal complex.

Type of the parameter	Value of the parameter			
Well production rate, t/day	25	50	75	100
Inner diameter, mm	50.3		62.0	
Heat transfer coefficient, $W/(m^2 \cdot ^\circ C)$	8.9	12.9	14.7	17.9
Wellhead oil temperature (without heating), $^\circ C$	20.2	23.6	24.7	25.8
Paraffin saturation temperature, $^\circ C$	31.9 (42.2)			
Length of the heated section of the well *, m	450 (900)	350 (750)	300 (700)	250 (650)
P_{spp}^{**} , kW	38 (159)	27 (126)	29 (155)	23 (136)

* - numbers in () refer to the paraffin concentration of 8%, without (), to 4%.

** - The power of energy sources is determined on the basis of stationary modes of operation of the complexes.

5 Conclusion

Thus, the use of a photovoltaic installation as an autonomous power source of the electrothermal complex with a heating cable provides maintenance of the average steady temperature along the wellbore above the point of crystallization of paraffin deposits in oil. The method takes the effect of the external climatic factor on the energy characteristics of the solar battery, thereby increasing the accuracy of forecast calculations in terms of power generation for the region under consideration.

According to the results of the study, it was determined that with concentration of paraffin up to 8%, the length of the heating cable is up to 900 m.

Based on the results obtained, the main technical parameters, structure, and operating modes of the autonomous complex were substantiated. The choice of the power of the photovoltaic installation as part of the complex was made, taking into account the following characteristics:

- Total solar radiation
- Heat-and-power characteristics of the well heating source
- Reservoir depth
- Oil waxing degree
- Daily well production rate
- Production method
- Distance from centralized power supply.

The average power of the complex ranges from 30 to 144 kW. The maximum power of the complex is required at minimum flow rate and maximum concentration of paraffin.

Autonomous heating systems using this technology, in comparison with traditional methods of preventing paraffin deposits, have the following advantages:

- Energy saving (does not require constant fuel supply, refueling, and frequent maintenance)
- Low metal consumption (does not require separate premises for installation and additional equipment)
- Low capital intensity (requires only a one-time investment and, according to preliminary calculations, the payback period will be no more than 3 years)
- Simplicity of the design (direct use of the DC power without additional converters);
- Environmental friendliness of the technology (by estimates, when using a photovoltaic installation as a power source for an electrothermal complex, the volume of greenhouse gas emissions is less than 20-30 tons of CO₂ eq. in a year. This indicator for autonomous electrothermal complexes on solar panels is 3-6 times lower than when using other energy sources (centralized power supply networks; local power supply networks based on diesel generator sets; mobile steam generators operating on diesel fuel). It is one of the main directions of environmental policy.

References

1. M.V. Bykova, M.A. Pashkevich, M.A. Matveeva, I.P. Sverchkov Assessment and abatement of the soil oil-contamination level in industrial areas, *Topical Issues of Rational Use of Natural Resource - Proceedings Of The International Forum-Contest of Young Researchers*, 347-359 (2019).
2. Y.L. Zhukovskiy, V.V. Starshaia, D.E. Batueva, A.D. Buldysko Analysis of technological changes in integrated intelligent power supply systems, *Innovation-Based Development of the Mineral Resources Sector: Challenges and Prospects - 11th Conference of the Russian-German Raw Materials*, 249-258 (2019).
3. Ministry of the Energy of Russia, *Energy strategy of the Russian Federation for the period up to 2035* (2020).
4. J. Sobota, V.I. Malarev, A.V. Kopteva Calculation of oil-saturated sand soils' heat conductivity, *Journal of Mining Institute*, **238**, 443-449 (2019).
5. Wang, W. 2014. Prediction for wax deposition in oil pipelines validated by field pigging. *Journal of the Energy Institute*(87): 196–207.
6. I.A. Struchkov, P.V. Roschin Effect of light hydrocarbons on wax precipitation. *International Journal of Applied Engineering Research*, *International Journal of Applied Engineering Research*, **11**, 9058-9062 (2016).
7. A. Belsky, A. Skamyin, E. Iakovleva, *International Journal of Applied Engineering Research*, **11(1)**, 233-238 (2016).

8. A.V. Kopteva, V.Yu. Koptev, V.I. Malarev, T.O. Ushkova Development of a system for automated control of oil transportation in the Arctic region to prevent the formation of paraffin deposits in pipelines, *E3S Web of Conferences*, 140-145 (2019).
9. B.Y.H. Liu, R.C. Jordan, Daily insolation on surfaces tilted towards the equator. *ASHRAE Journal*, **3**, 53–59 (2013).
10. L. Kovrigin, I. Kukharchuk Automatic control system for removal of paraffin deposits in oil well in permafrost region by a thermal method, *Chemical Engineering Research and Design*, **115**, 116-121 (2016).
11. M. Obaseki, P.T. Elijah Dynamic modeling and prediction of wax deposition thickness in crude oil pipelines, *Journal of King Saud University - Engineering Sciences* (2020). Open Weather Map2020. <https://openweathermap.org>.
12. P. Tcvetkov, A. Cherepovitsyn, A. Makhovikov Economic assessment of heat and power generation from small-scale liquefied natural gas in Russia, *Energy Reports*, **6(2)**, 391-402 (2020).
13. M.A. Pashkevich, T.A. Petrova Technogenic impact of sulphide-containing wastes produced by ore mining and processing at the Ozernoe deposit: Investigation and forecast, *J. Ecol. Eng.*, **18(6)**, 127–133 (2017).
14. F.L. Balo, L. Şağbanşua The selection of the best solar panel for the photovoltaic system design by using AHP, *Energy Procedia*, (**100**), 50–53 (2016).
15. J.A. Duffie *Solar Engineering of Thermal Processes*, ERIRAS 2013. *Energy development forecast the world and Russia until 2040* (Russian language) (2013).
16. A.A. Nikolaev Indirect methods for calculating the characteristics of solar radiation, *Bulletin of the Udmurt University*, 130-135 (2013).
17. A. Lavrik, E. Iakovleva, A. Leskov Assessing the solar power plant efficiency degradation resulting from heating, *Journal of Ecological Engineering*, **19(3)**: 115-119 (2018).
18. V.S. Dobush, A.A. Belsky, A.N. Skamyin Electrical complex for autonomous power supply of oil leakage detection systems in pipelines, *Journal of Physics: Conference Series* 5-7 (2020).