

# Improving the efficiency of autonomous wind turbines

*Olga Pchelnikova-Grotova\**

Moscow Aviation Institute, Russia

**Annotation.** The article discusses the development of a mathematical model of a combined wind turbine of a multi-modular wind power plant, which makes it possible to control the operation of wind turbines with the greatest efficiency, changing the operating modes of the installation depending on the wind flow entering the inlet. The implementation of the developed model at a multi-module wind station allowed us to obtain a maximum wind utilization factor of 0.35-0.47 at any wind speeds, as well as at low wind speeds to increase the initial torque of the wind wheel by 4 times in comparison with typical power plants.

## 1 Introduction

A significant part of the territory of Russia is located in the zone of decentralized power supply, and in most regions the average wind speed does not exceed 4 m/s, so the use of traditional wind power plants (WPP) becomes economically inexpedient [1]. Using the huge wind potential of Russia (more than 50,000 billion kWh/year) can provide about 30% of the country's electricity generated [2, 3, 4, 5, 6].

The problem of a more complete use of the wind potential can be solved by using multi-modular wind power plants, consisting of modules, which are combined reconfigurable wind turbines (CRWT), combining the advantages of low-speed (multi-blade) and high-speed (low-blade) wind turbines (WT) [7, 8].

## 2 Materials and Methods

With an increase in the number of blades, the WT starts to rotate at a lower wind speed. However, a wind wheel with a small number of blades makes a higher number of revolutions. This is an important advantage, as it simplifies the transmission of power to the generator. In addition, high-speed WTs have a lighter weight and a higher utilization rate of wind energy in comparison with low-speed WTs [9, 10].

The combined wind turbine, which is part of the multi-modular wind farm, structurally consists of three independent wind turbines: two high-speed three-bladed and one low-

---

\* Corresponding author: [grotova@mail.ru](mailto:grotova@mail.ru)

speed six-bladed. The wind wheels are fixed on one shaft, and the rotary blades of each of them are fixed on the bushings, which allows the blades to rotate freely [11].

WT operating modes depend on the speed of the wind flow [12]. At a low wind speed (3-4 m/s), all twelve CRWT blades, combined in one plane, operate in order to ensure the maximum torque at a sufficiently high coefficient of wind energy utilization (Fig. 1, a).

At an average wind speed (4-7 m/s), the bushing of the six-bladed WT is disconnected from the bushing of the main WT, shifts to the right and stops working. Two WTs remain workers (Fig. 1, b).

At a high wind speed (7-13 m/s), the bushing of the three-bladed WT is disconnected from the bushing of the main wheel, shifts to the left and stops rotating. In this case, the main WT continues its work with the maximum rotation speed, and the inoperative WT do not interfere with the rotation of the main one, but act as guides for the wind flow (Fig. 1, c).

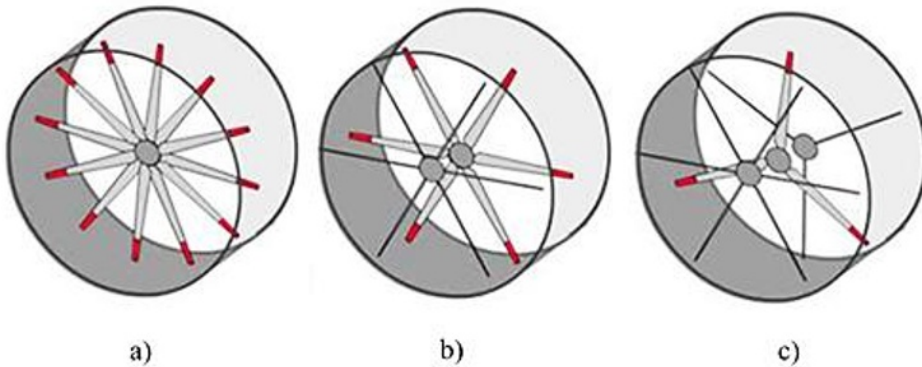

**Fig. 1.** Modes of CRWT operation at low (a), medium (b) and high (c) wind flow velocities

As a result, in all modes of WPP operation, the main WT bushing remains stationary on the shaft, and the extreme bushings move along the longitudinal axis of the shaft, depending on the wind speed.

In order for the multi-modular wind turbine to work with maximum efficiency, it is necessary to alternately turn on the wheels included in the CRWT, which have a different number of blades. For this purpose, a mathematical model of the CRWT was developed, which allows to control this process [13].

The efficiency of the wind wheel is characterized by the speed  $Z$  and the coefficient of use of wind energy  $C_p$  [14].

The wind wheel coefficient  $C_p$  is the ratio of the energy converted into mechanical work to the total energy of the wind flow. The maximum value of  $C_p$  can be obtained only at a certain speed, that is, for each wind speed there is a single value of the number of revolutions at which  $C_{pmax}$  is reached [15].

The dependence of  $C_{pmax}$  on the design parameters of the wind wheel is approximated by a quadratic parabola [16].

$$C_{pmax} = (-0,109\delta_c^2 + 0,18514\delta_c^2 + 0,4283) \cdot 0,825 \quad (1)$$

$$\delta_c = \frac{2\tau_b b_c}{D} \quad (2)$$

here  $\tau_b$  is the number of WT blades;  $b_c$  – section chord at the end of the blade, m;  $D$  is the diameter of the WT, m.

The dependences of the optimal  $Z_{opt}$  and maximum  $Z_{max}$  speed on the WT parameters on are approximated by hyperbolic relations [17].

$$Z_{opt} = \frac{30,78\delta_l + 18,58}{12,74\delta_l + 1} \quad (3)$$

$$Z_{max} = \frac{188,93\delta_l + 20,62}{28,22\delta_l - 1} \quad (4)$$

Thus, the calculated parameters were obtained for the WT of an experimental multi-modular installation with three, six and twelve blades (Table 1).

**Table 1**

Number of wheels	$C_{pmax}$	$Z_{opt}$	$Z_{max}$
3	0,47	3,5	9,2
6	0,44	2,6	7
12	0,35	1,2	2,7

The dynamics of rotation of the CRWT can be described by the differential equation [18]

$$J_{CVK} \frac{d\omega}{dt} = M_{CVK} - M_r - M_v, \quad (5)$$

here  $J_{CVK}$  is the moment of inertia of the wind wheel-generator system;  $\omega$  is the angular frequency of rotation of the wind wheel, rad/s (the angular frequency of rotation of the wind wheel is equal to the angular frequency of rotation of the generator rotor, since the wind wheel is connected to the generator according to a gearless scheme);  $M_{CVK}$  - mechanical moment of rotation of CRWT at optimum speed, N·m;  $M_r$  is the electromagnetic moment of the generator rotor, N·m;  $M_v$  is the moment of resistance of the shaft, N·m.

Consider the moment characteristic of the device without taking into account the electromagnetic moment of the generator rotor and the moment of resistance of the shaft. We obtain the following equation for the dynamics of the CRWT [19]

$$J_{CVK} \frac{d\omega}{dt} = M_{CVK} \quad (6)$$

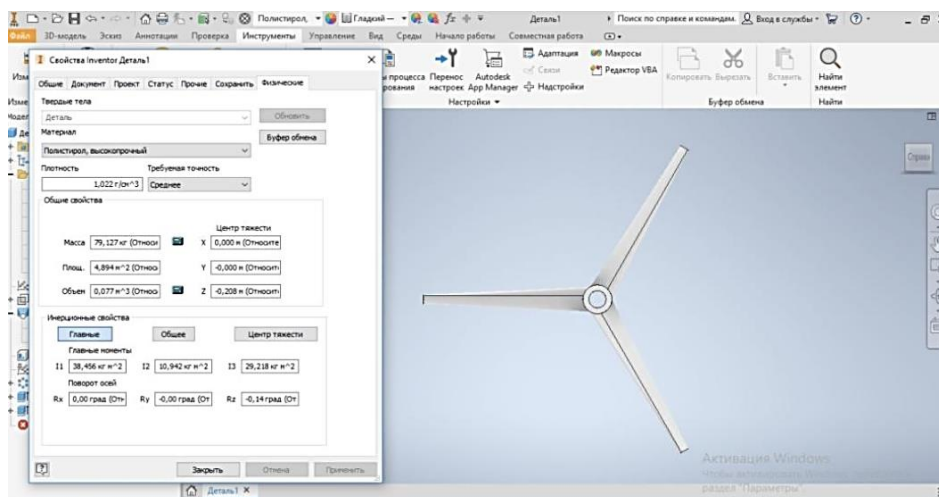

**Fig. 2.** Model of a 3-blade WT in Autodesk Inventor

To determine the moment of inertia of the combined wind turbine  $J_{wt}$  we used the Autodesk Inventor program, in which a simplified model of a three-bladed WT with blades made of high-strength polystyrene was created. Initial parameters of the wind wheel: mass  $m = 79.127$  kg; area  $S = 4.894$  m<sup>2</sup>; volume  $V = 0.077$  m<sup>3</sup>, material density  $\rho_0 = 1.022$  g/cm<sup>3</sup>; moments of inertia along the X, Y and Z axes were  $J_X = 38.456$  kg·m<sup>2</sup>,  $J_Y = 10.942$  kg·m<sup>2</sup>,  $J_Z = 29.218$  kg·m<sup>2</sup>, respectively. The position of the center of gravity along the axes:  $g_X = 0$ ,  $g_Y = 0$ ,  $g_Z = -0.208$  ° (Fig. 2).

### 3 Results and Discussion

The results of calculating the dependences of the angular speed of rotation and power of the WT on the speed, torque and coefficient of use of wind energy at different wind speeds for three types of wheels are presented in the form of the power characteristics of the WT for wind speeds from 3 to 13 m/s (Table 2).

**Table 2**

Number of blades WT	Characteristics graph	
12	Torque	
	Power	

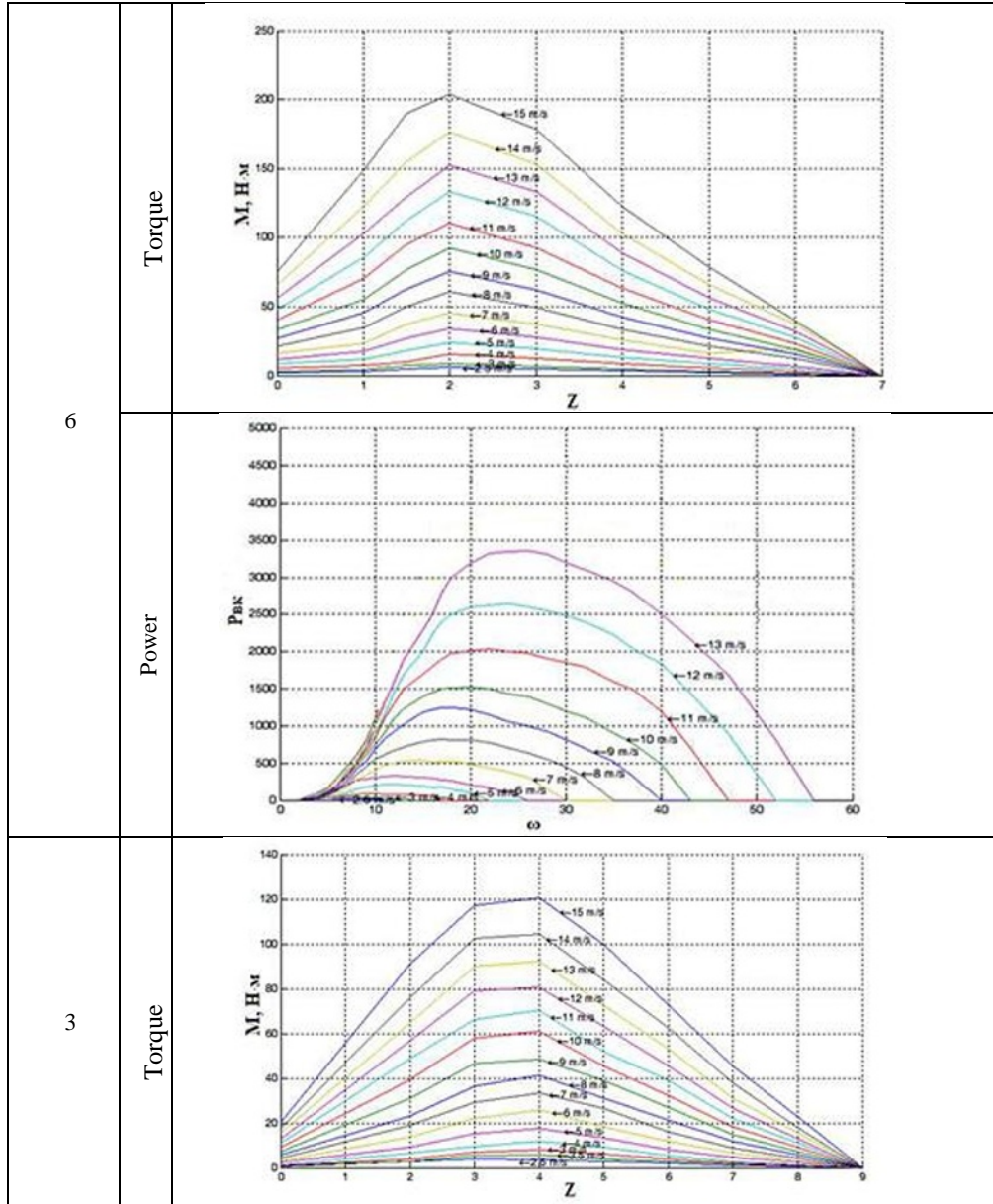

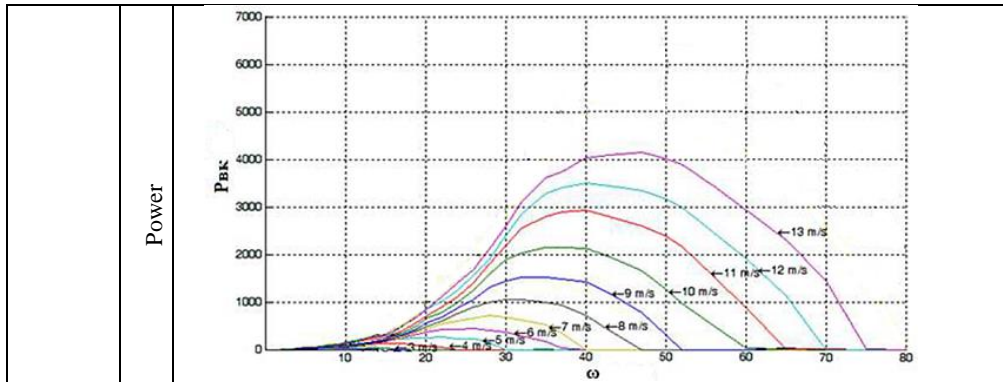

The obtained characteristics make it possible to determine the number of revolutions of the WT, at which the maximum for each value of the wind speed will be reached, which makes it possible to adjust the operation of the WT to obtain a high utilization of wind energy.

To describe the dynamics of rotation of the wind wheel depending on the wind load, a mathematical model of the CRWT was developed, consisting of five blocks: "Calculation of wind speed", "Calculation of the generator operating mode", "Number of working blades of a wind generator", "Calculation of the moment of a wind generator", "Description of dynamics rotation of the rotor". The diagram of the mathematical model of the CRWT is shown in Fig. 3.

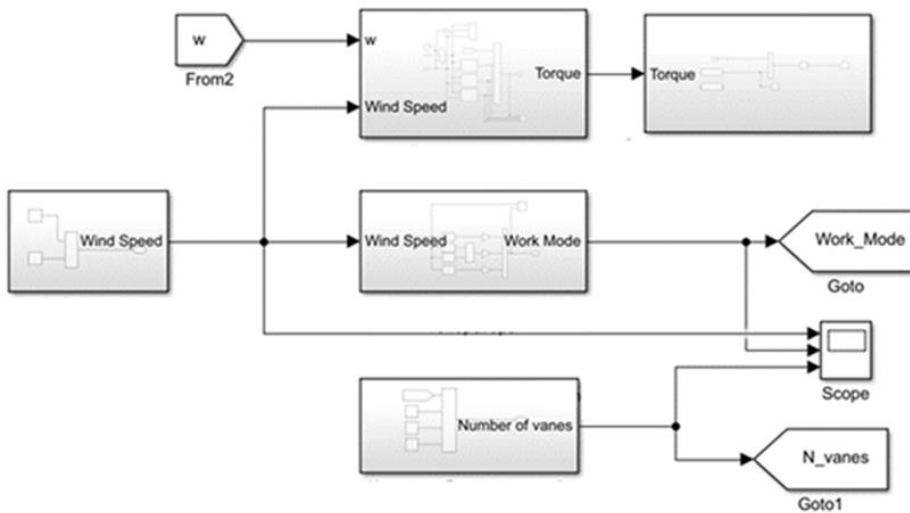

**Fig. 3.** Scheme of the mathematical model of a combined wind wheel of a multi-modular wind farm

Let's consider the operation of one of the blocks of the presented model. The block "Calculation of the generator operating mode" (Fig. 4) is designed to select the generator



operating mode (12, 6 and 3 blades of the WT are active) depending on the calculated wind speed.

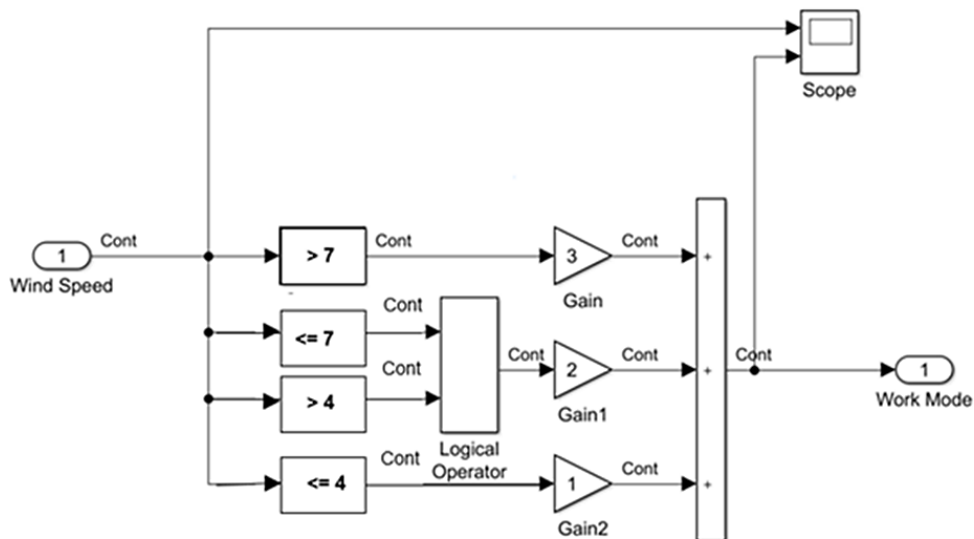

Fig. 4. Diagram of block "Calculation of the generator operating mode"

Based on the results of the block's operation, graphs of the dependence of the operating mode of the wind wheel on the input wind speed are built (Fig. 5) at each moment of time.

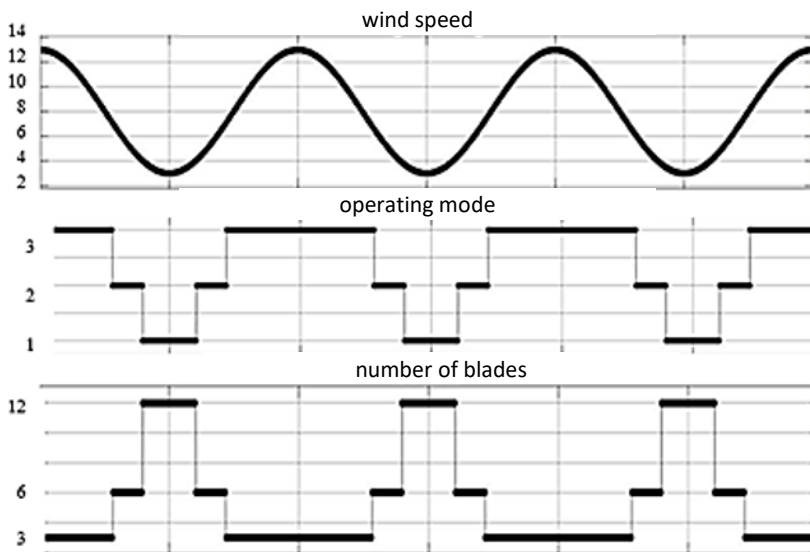

Fig. 5. Graphs of operating modes of WT and wind speeds

At the maximum wind speed (range from 7 to 13 m/s) three blades of the CRWT operate, at an average speed (range from 4 to 7 m/s) - six blades of the CRWT and at the minimum speed (range from 3 to 4 m/s) – all twelve blades of the CRWT. In this case, the combined wind turbine in each mode operates at optimal speed, which increases the torque and the number of revolutions of the shaft.

## Conclusion

The developed mathematical model of the CRWT allows you to control the operation of the wind turbine with the greatest efficiency, changing the operating modes of the wind wheels, depending on the incoming wind flow. The software implementation of the simulation model made it possible to obtain at the wind power plant the maximum wind energy utilization rate of (0.35 - 0.47) in the range of wind speeds from 3 to 13 m/s and the initial torque is 4 times greater than that of typical 3-blade wind power plants at low wind speed.

## References

1. R. Karki, R. Billinton, IEEE, **16**, 4 (2001).
2. The Power of Transformation, Wind, Sun and the Economics of Flexible Power Systems, IEA (2014).
3. O. Grotova, M. Min, Information support for calculating the wind energy resources of the Republic of Myanmar for ground-based flight support systems, in Materials of the 25th International Scientific and Technical Conference Modern technologies in problems of control, automation and information processing, 14-20 September 2016, Alushta, Russia (2016).
4. M. Strickland, E. Arnett, W. Erickson, D. Johnson, G. Johnson, M. Morrison, J. Shaffer, W. Warren-Hicks, Comprehensive guide to studying wind energy/Wildlife interactions. NWCC (2011).
5. M.R. Islama, S. Mekhilefb, R. Saidura, RSER, **21** (2013).
6. G.M. Joselin Herberta, S. I.niyانب, E. Sreevalsanc, S. Rajapandiand, Renewable and Sustainable Energy Reviews, **11**, 6 (2007).
7. S. Stepanov, Multi-modular wind power plant of combined type for an extended range of wind loads, in materials of the 6th All-Russia scientific-practical conference Innovative technologies in training and production, Kamyshin, Russia (2009).
8. I Artyukhov, S. Stepanov, E. Mirgorodskaya, V. Kovalenko, N. Mityashin *Multi-modular Wind Generators for Urban Wind Power*, in Materials of 16th Conference on ELMA, 6-8 June 2019, Varna, Bulgaria (2019).
9. O. Pchelnikova-Grotova. Electronics: STB. **1** (2019).
10. K. Kovalev, V. Penkin, N. Ivanov, N. Kosheleva, G. Serovaev, IOP Conf. Series: MSE, **581** (2019).
11. O. Solomenkova, I. Pavlenko, Characteristics of the combined wind wheel, in Materials of the Bulletin of the Saratov State Technical University, **4**. (2010).



12. A. Beainy, C. Maatouk, N. Moubayed, F. Kaddah, *Comparison of different types of generator for wind energy conversion system topologies*, in Proceedings of 3rd International Conference on REDEC, IEEE, 13-15 July 2016, (2011).
13. G. Ofualagba, E. Ubeku, *Wind energy conversion system - wind turbine modeling*, in Proceedings of Power and Energy Society General Meeting - Conversion and Delivery of Electrical Energy in the 21st Century, 20-24 July 2008, (2008).
14. R. Billinton, Y. Gao, *Multistate Wind Energy Conversion System Models for Adequacy Assessment of Generating Systems Incorporating Wind Energy*, TEC, IEEE, **23**, 1 (2008).
15. P. Bezrukikh, *Wind power: reference and methodological manual*. Publishing House "Energy", (2010).
16. A. Rykhlov, *On the Question of Approximating Wind Velocities in the South-East of the European Territory of Russia by the Weibull – Goodrich Distribution Law*, in Materials of the Bulletin of the Saratov University, **10** (2010).
17. R. Datta; V.T. Ranganathan, *A method of tracking the peak power points for a variable speed wind energy conversion system*, TEC, IEEE, **18**, 1 (2003).
18. M. Baloch, J. Wang, G. Kaloi, *A Review of the State of the Art Control Techniques for Wind Energy Conversion System*, IJRER, **6**, 4 (2016).
19. A. Manyonge, R. Ochieng, F. Onyango, J. Shichikha, *Mathematical modelling of wind turbine in a wind energy conversion system: Power coefficient analysis*, in Applied Mathematical Sciences, (2012).