

Kinematics of the seedling plant with vertical distributor and buckets

*Paul-Marius Mitrache*¹, *Radu Ciupercă*², and *Ioan Sărăcin*³

^{1,3} University of Craiova, Romania

² National Institute of Research Development for Machines and Installations Designed to Agriculture and Food Industry – INMA, Bucharest, Romania

Abstract. In this paper are presented some theoretical and experimental research on the kinematics of planting seedlings of vertical disc type and buckets, the variant of planting directly in the cultivated soil, the kinematics that must ensure the correlation between the working speed of the planting equipment and the speed periphery of the bucket, so that the seedling is planted in an upright position. After a brief presentation of the research carried out worldwide in the field, the kinematic scheme of the planting apparatus and the condition that must be fulfilled by the construction and operation of the apparatus for the correct planting of the seedling are presented. The relations for the projections of the studied point, called the tracer (root of the seedling) and of the afferent angular velocity, are written in a system of xOy coordinates. Using the real values of a studied planting machine, the real and corrected trajectories of the studied tracer point were drawn, using the MatLab program. Following the research, the related conclusions and recommendations for improvement were formulated.

1 Introduction

The realization of a mechanized work for planting vegetable seedlings corresponding to quality, with final implications in obtaining high yields per unit area, involves compliance with agrotechnical requirements the work of planting seedlings that can be divided into three categories, as follows [1,2]:

- Agrotechnical requirements regarding land preparation;
- Agrotechnical requirements regarding the planting work;
- Requirements imposed by regulations.

The cultivation of vegetables through seedlings has an important place, one of the important problems in the technological process is planting, an operation that is overwhelmingly mechanized.

Seedling planting equipment has experienced a spectacular development over time, the technical solutions developed, especially for the planting apparatus, have been very diversified [3], and following multiple comparative research, it has been concluded that those equipped with vertical discs and buckets achieve working parameters in accordance with the agrotechnical requirements at the highest level [4,5].

The improvement of the planting devices took place in the direction of their automation, a situation in which it was necessary to find technical solutions that would especially take over the seedling from the support and place the seedling in the gutter or directly in the soil.

Worldwide, the issue of solving the requirement of planting seedlings in an upright position has been addressed by countless specialists, who have developed several types of pick-up and planting mechanisms for automatic planting machines, the results being published in well-known journals published on world plan.

We mention thus a mechanism for taking over the seedlings with a nutritious bale, of the type with planetary gear train, mechanism that equips an automatic planting system that takes the seedling from the pot and positions it so that, when it is released, the seedling is released in the gutter. sol fig. 1 [6].

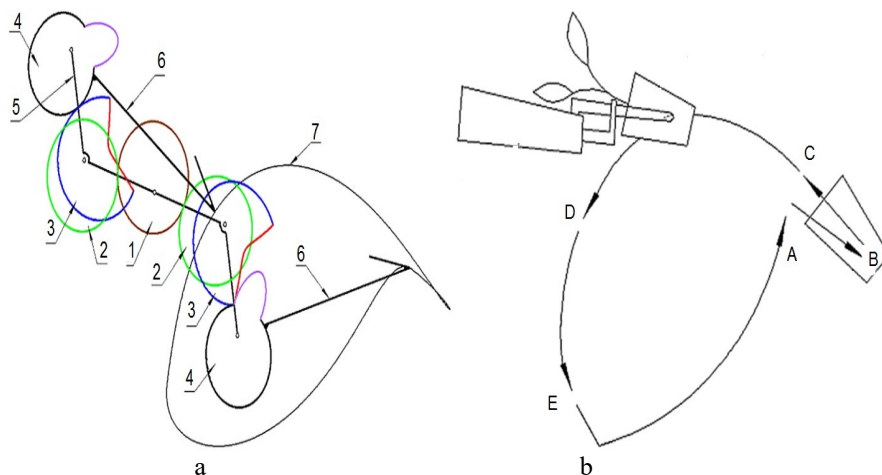

Fig. 1. Seeding bale picking mechanism with gear train planetary and take-up arms
a) 1. Two-jaw pattern of the seedling pick-up mechanism; 2. Sun gear, 3. First middle gear, Second middle gear, 4. Planet gear, 5. Planet frame, 6. Seedling arm, and 7. Seedling pick-up trajectory. b) trajectory characteristics of the seedling mechanism

An analysis of the trajectory characteristics of the seedling mechanism indicated that the ideal seedling trajectory requires an arm of a certain length that makes a path of the seedling A - B - C - D - E.

Another achievement is a device for taking seedlings from pots, with reciprocating movement and control system of the seedling planter, fully automatic [7].

On this system it was found that the positioning accuracy of the linear transmission device gradually decreases with increasing speed of seedlings, especially when the pulse frequency of the electric control motor exceeds 20,000Hz. The engine goes out of gear and the accuracy will decrease rapidly. The motor parameters can be optimized by setting the different pulse frequencies and setting the range of error values between 0.2 mm and 0.8 mm, which depends on the requirement of seedling positioning.

Another achievement is an automatic mechanism for taking over and planting seedlings with a high-precision asymmetric transmission train, fig. 2.

The pick-up mechanism removes the seedlings from the seedling tray and transports them to the floppy planter that plants them in the soil [8].

As shown in fig. 2, the angle between the seedling tray and the horizontal plane is 60° , ie relative to the suppling position of the seedling, the rotation angle of the execution component (seedling gripping component) being approx. 150° . When placed on the floppy disk, the seedling has a horizontal position.

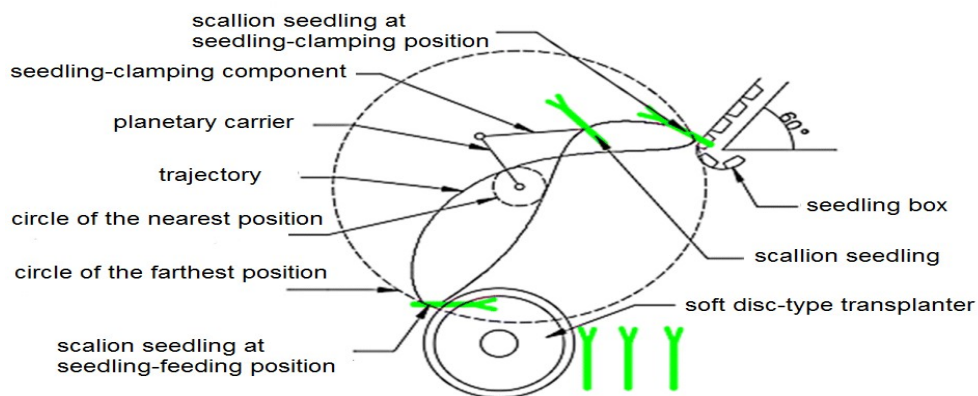

Fig. 2 Automatic mechanism for taking and planting seedlings with asymmetric transmission train, high precision [8]

A bucket-type planting machine, used for planting seedlings with a nutrient bowl, consisting of conical buckets, a guide tube and a soil compaction wheel, is another notable achievement [9].

Another model has conical cups attached to the drum which is driven by a soil compaction wheel [10], fig. 3. It is a high speed planter that extracts the seedlings directly from a tray with seedlings, the functions of making holes in the soil, withdrawing and depositing the plants, being performed at absolute zero speed of the seedling, at the time of planting.

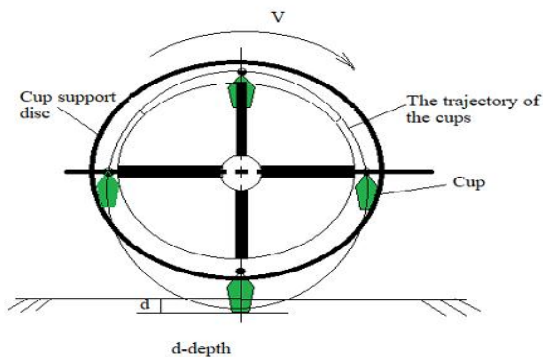

Fig. 3. Mechanism equipped with disc-type devices with cups for planting vegetable seedlings [10]

2 Materials and methods

To carry out the experiments, a planting machine was used, equipped with a distributor with articulated cups, in aggregate with a 45 hp vegetable tractor fig. 4.



Fig.4 Machine for planting vegetable seedlings and herbs in a row, MPA symbol (**** INMA Bucharest, 2018)
 1-Frame, 2- planter, 3- transmission, 4- rear support wheels, 5 –compaction wheels, 6- rack, 7- track marker

The condition for the planted material to be placed in a vertical position is that the absolute velocity V_a of the material, at the time of planting, be approximately zero ($V_a = 0$). This becomes possible when the ratio λ_T is defined according to relation (1), in this case, the considered point moving after a normal cycloid, fig. 5, [11].

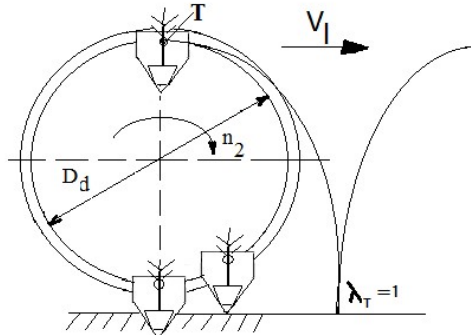

Fig. 5. Diagram of the working process of the disc planting machine with cups, with the placement of the seedling directly in the soil

$$\lambda_T = \frac{V_p}{V_l} = 1 \quad (1)$$

in which:

- V_p - peripheral speed of the planting device, m/s;
- V_l - working speed of the machine, m/s.

The condition that the seedlings be planted at equal distances between rows can be achieved if there are no losses in the transmission chain, or the losses are minimal, so that the deviations from the distance between plants in a row fall within the values accepted by users.

The mentioned deviations can be caused by the losses in the kinematic chain of the transmission or by the non-uniformity of the drive wheel movement at the contact with the soil, which can be manifested by the sliding of the wheel, this cause being most frequently encountered when operating planters.

According to the kinematic diagram of the machine fig. 6 [12], the transmission of the movement from the drive wheel to the bucket distributor is very simple, this being made up of only two chain transmissions, thus achieving minimal losses in the powertrain.

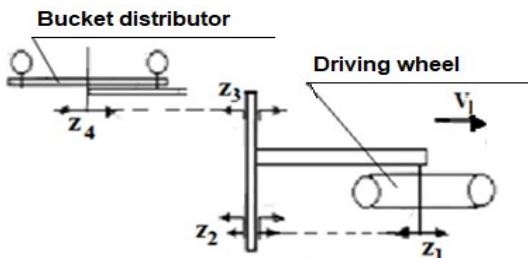

Fig. 6. Kinematic diagram of the transmission of the planter with vertical distributor and cups [12]

The rotational frequency of the rotary distributor is determined by the relation (5.2).

$$n_2 = n_1 \cdot i = n_1 \cdot i_1 \cdot i_2 = n_1 \cdot \frac{z_1}{z_2} \cdot \frac{z_3}{z_4} = \frac{30 \cdot v_l}{\pi \cdot R_a} \cdot \frac{z_1}{z_2} \cdot \frac{z_3}{z_4} \quad (2)$$

in which:

R_a - radius of the drive wheel, m;

v_l - speed of movement of the aggregate, m/s;

n_1 - drive wheel speed, s^{-1} ;

n_2 - speed of the vertical distributor with buckets, s^{-1} .

Kinematics of the planter with vertical disc and cups

To meet the requirement to place the seedling in the ground in a vertical position, expressed by relation (1), the equations for defining the coordinates on the X and Y axes of the reference point for the cycloid root of the seedling and the projections of the velocity of the drawer point T , which has a trajectory similar to point A defined above, on the axes of the orthogonal system XOY .

The expression of the motion relations for the tracer point T was adopted, fig. 6, for reasons of accuracy of defining its actual position on the distributor disk, this point representing the point of fixing the cups on the disk.

It know:

V_l - working speed of the planting machine, m/s;

ω_l - angular speed of the drive wheel, rad/s ;

Z_1, Z_2, Z_3, Z_4 - the number of teeth of the chain wheels ;

R_a - radius of the drive wheel, m;

R_d - the radius of arrangement of the cups on the distributor, m.

It is considered a kinematic cycle of the drive wheel. The angular velocity of the distributor is higher than the angular velocity of the drive wheel to compensate for the difference between the radius of the drive wheel and the radius of arrangement of the cups on the distributor disc. This was achieved by the transmission ratio between the chain wheel Z_1 and Z_2 .

It is determined:

ω_2 - angular velocity of wheels 2 and 3, rad/s;

ω_4 - angular speed of wheel 4 (angular speed of distributor), rad/s;

X_T, Y_T - the coordinates of the center of the cups (tracer point T), m;

V_{TX}, V_{TY} - the projections of the speed of the tracer point T , on the axes of the orthogonal system, m/s.

The transmission ratios expressed by angular velocities are according to the relations (3).

$$i_{12} = \frac{\omega_1}{\omega_2} = \frac{z_2}{z_1} \Rightarrow \omega_2 = \omega_1 \cdot \frac{z_1}{z_2}; \omega_1 = \frac{V_l}{R_d} \quad (3)$$

$$i_{14} = \frac{\omega_1}{\omega_4} = i_{12} \cdot i_{34} = \frac{z_2}{z_1} \cdot \frac{z_4}{z_3} \Rightarrow \omega_4 = \omega_1 \frac{z_1 \cdot z_3}{z_2 \cdot z_4}$$

The position of the tracer point T on the bucket distributor, relative to the reference system XOY is represented in fig. 7 and is expressed by the relations (4). T_0 is the starting point from which the movement of the cup distributor is considered.

$$X_T = X_{C_4} + V \cdot t + R_d \cdot \sin \varphi_4 \quad (4)$$

$$Y_T = Y_{C_4} + R_d \cdot \cos \varphi_4$$

Or relations (5).

$$X_T = X_{C_4} + V \cdot t + R_d \cdot \sin \omega_4 \cdot t \quad (5)$$

$$Y_T = Y_{C_4} + R_d \cdot \cos \omega_4 \cdot t$$

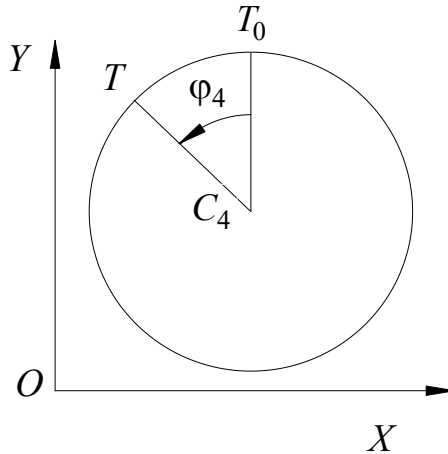

Fig. 7. Tracer point position T

The projections of the speed of the tracer point T , with respect to the reference system XOY , are expressed according to the relations (6).

$$V_{TX} = V_l - R_d \cdot \omega_4 \cdot \sin \omega_4 \cdot t \quad (6)$$

$$V_{TY} = R_d \cdot \omega_4 \cdot \cos \omega_4 \cdot t$$

3 Results and discussion

For plotting the kinematic curves of the planting machine of the tested planting machine [12], the real values of the dimensions of the components of a seedling planting equipment used, according to fig. 8.

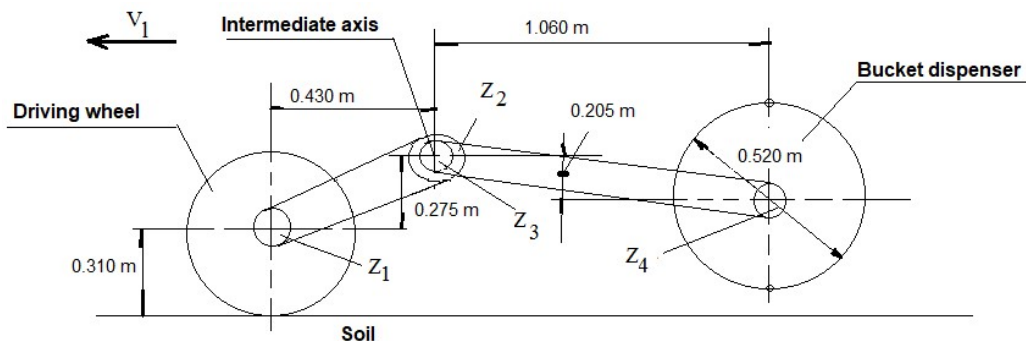

Fig. 8. Schematic of the planting machine [12]

$z_1 = 25$ teeth;

$z_2 = 23$ teeth;

$z_3 = 15$ teeth;

$z_4 = 15$ teeth;

$R_a = 0.31$ m;

$R_d = 0.26$ m.

$V_1 = 1.15; 1.55; 2.15$ km/h or $0.319; 0.431; 0.597$ m/s - speeds used for experiments.

The real kinematics of the studied planting apparatus is shown in fig. 9

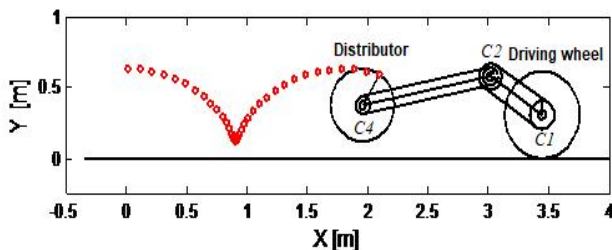

Fig. 9. The real kinematics of the studied planting apparatus

Using the real values of the planting machine used in the testers, the variation diagrams of the projection of the speed of the tracer point T , were drawn. fig. 10-12.

The real values of the constructive parameters of the machine used in the experiments are presented by quotation on the diagram in Fig. 8 and were measured stationary on a concrete platform, and the values for R_a ; R_d , and the number of teeth of the chain wheels are as follows: $z_1 = 25$ teeth; $z_2 = 23$ teeth; $z_3 = 15$ teeth; $z_4 = 15$ teeth; $R_a = 0.31$ m; $R_d = 0.26$ m; $V_1 = 0.319$; m/s.

The diagrams in fig. 10-12 were drawn using relation (6) the variable is time and ω_4 was calculated with relation (3), using the values mentioned above.

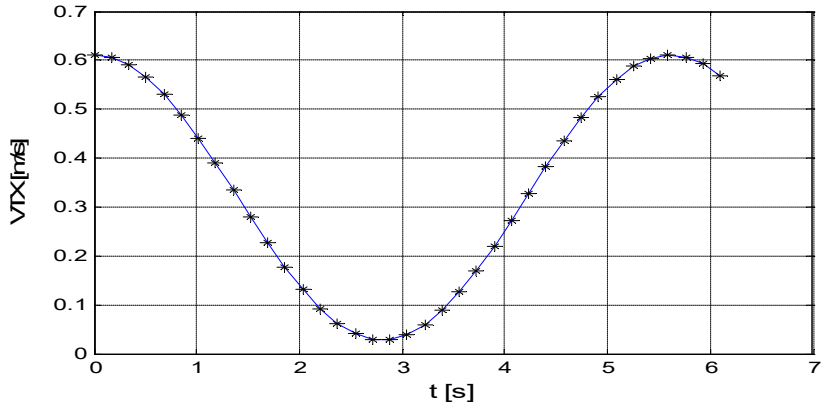

Fig. 10. Diagram of the variation of the speed projection of the tracer point T (for $Z_2 = 23$ teeth)

To satisfy the condition expressed by relation (1), the curve should have been tangent to the 0 line of the diagram. The difference is caused by the drive wheel slipping on contact with the soil, a phenomenon often encountered in the operation of such equipment.

Taking into account the above, the diagram was corrected by reducing the number of teeth on the wheel Z_2 to 21 teeth, thus resulting in the ideal curve according to fig. 11.

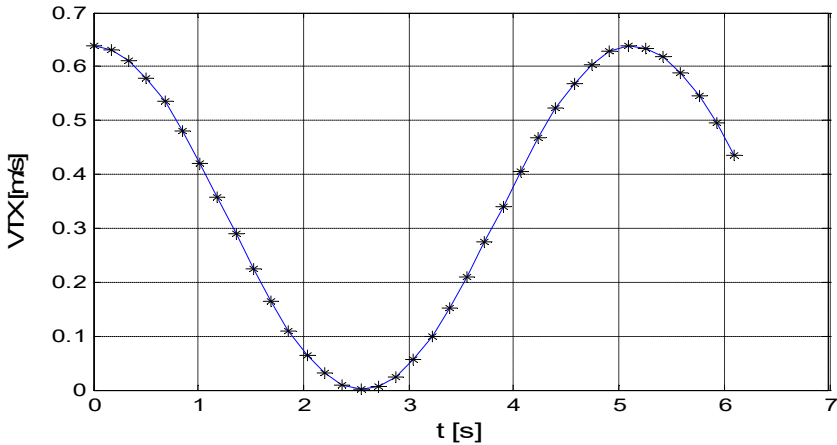

Fig. 11. Corrected variation diagram of the speed projection of the tracer point T, (for $Z_2 = 21$ teeth)

To draw the variation diagram of the projection of the velocity of the point representing the root of the seedling, point T, fig. 5, the radius of the distributor R_d was corrected, thus resulting in the diagram according to fig. 12.

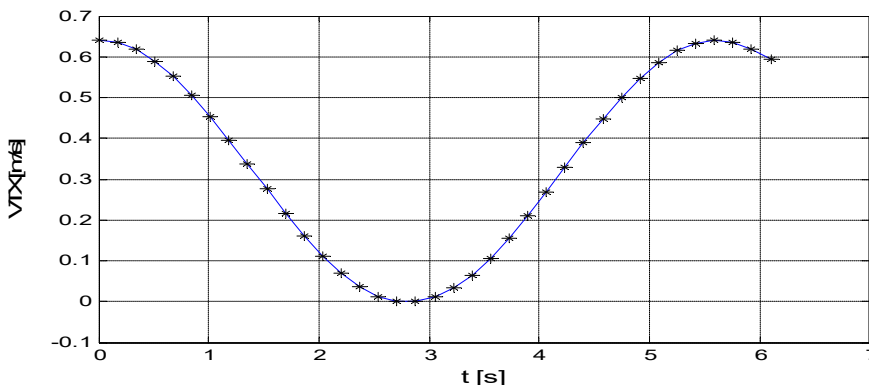

Fig. 12 Diagram of variation of seedling root velocity projection ($R_d+0.02627$ m and $z_2=23$)

4 Conclusions

- the condition that the planted material be placed in a vertical position, is that the absolute speed V_a of the seedling, at the root level, at the time of planting, be approximately zero ($V_a = 0$). This becomes possible when the ratio λ_T defined as the ratio V_l/V_p is as close as possible to the value 1, in this case, the point considered moving after a normal cycloid;

- for the analysis of the way of fulfilling the condition $V_l/V_p = 1$, the kinematics of a planting device with vertical disc and buckets were made, the equations of motion of the tracer point (distributor bucket joint) and of its angular velocity in an xOy coordinate system and the diagrams of variation of the projection of the speed of the tracer point were drawn, according to its constructive and functional parameters;

- from the determined diagrams, using the real parameters of the planting equipment, resulted minor deviations from the ideal trajectory (normal cycloid), reason for which it was necessary to correct it by varying the number of teeth of the chain wheel z_2 , from 23 to 21 of teeth, fig. 10-11;

- for plotting the variation curve of the projection of the seedling root speed, the radius of the distributor was corrected, at a value $R_d + 0.02627m$, following which the ideal curve resulted, fig. 12.

5. References

1. V. Popescu, A. Popescu, *Cultura legumelor din camp și solarii* (Vegetable crop in field and solariums), Editura MAST (MAST Publishing House), Bucharest, (2006).
2. T. Stan, *Tehnologia cultivării legumelor*, Editura Alfa, (2005).
3. C. Muraru-Ionel, *Mașini cu discuri flexibile pentru plantat răsaduri legumicole* (Machines with flexible disks for planting vegetable seedlings), Editura Terra Nostra (Terra Nostra Publishing House), Iași, Romania, (2009).
4. P.M. Mitrache, I. Saracin, R. Ciuperca, *Comparative study on seedlings planting machines with cups dispensers ISB-INMA-TEH*, International Symposium, Bucharest, Romania, pp. 796-803, (2019).
5. SR 13215:1994 - *Mașini de plantat răsaduri. Condiții tehnice de calitate* (Seedlings planting machines. Quality technical conditions), ASRO, Romania, (1994)..

6. T. Zhipeng, Y. Gaohong, Z. Xiong, L. Pengfei, Y. Bingliang, Design of Vegetable Pot Seedling Pick-up Mechanism with Planetary Gear Train, Chinese Journal of Mechanical Engineering, Volume **33**, Article number: 63, (2020).
7. Q Z Yang, L Xu, X Y Shi, et al. *Design of seedlings separation device with reciprocating movement seedling cups and its controlling system of the full-automatic plug seedling transplanter. Computers & Electronics in Agriculture*, 147: pp. 131-145. <https://doi.org/10.1016/j.compag.2018.02.004>, (2018).
8. Z. Xiong, Y. Jun, C. Mengyan, C. Jianneng, Automatic Scallion Seedling Feeding Mechanism with an Asymmetrical High-order Transmission Gear Train, Chinese Journal of Mechanical Engineering, Volume **33**, Article number 10, (2020).
9. A. Khadatkar, S. M. Mathur, B. B. Gaikwad, 2018, *Automation in transplanting: a smart way of vegetable cultivation*, CURRENT SCIENCE, Volume. 115, NO. 10, 25 NOVEMBER, pp.1884-1892. (abhijitnu2@gmail.com), (2018).
10. R. D. Munilla. L. N. Shaw, *A high speed dibbling transplanter*, Trans. ASAE, 30(4), pp. 904–908, (1981).
11. V. Scripnic, P. Babiciu, *Masini Agricole*, Editura Ceres, pp. 206, Bucuresti, (1979).
12. *Tehnologie de înființare și valorificare superioară a materiei prime vegetale obținută din plante medicinale (Technology for the establishment and higher recovery of plant raw material obtained from medicinal plants)* , INMA Bucharest, Romania. Available at: www.inma.ro/Proiecte/Proiecte CDI Program NUCLEU/Project PN 18 30 02 03, (2018).