

# Study on machine for processing and preparing the soil for sowing potatoes on ridges

*Bakhadir Mirzaev*<sup>1</sup>, *Farmon Mamatov*<sup>2,3</sup>, *Uchkun Kodirov*<sup>2\*</sup>, and *Dustmurod Chuyanov*<sup>3</sup>

<sup>1</sup>Tashkent Institute of Irrigation and Agricultural Mechanization Engineers, 100000, Tashkent, Uzbekistan

<sup>2</sup>Karshi Engineering Economic Institute, 180100, Karshi, Uzbekistan

<sup>3</sup>Karshi branch of Tashkent Institute of Irrigation and Agricultural Mechanization Engineers, 180119, Karshi, Uzbekistan

**Abstract.** The technologies used to prepare the soil for sowing potatoes on ridges, consisting of numerous soil preparation operations, lead to loss of moisture, prolonging the sowing period and increasing operating costs. The aim of the research is to develop a machine for processing and preparing the soil for sowing potatoes on ridges. The authors have developed a technology for preparing fields for sowing potatoes on ridges and a machine for its implementation. The basic principles and methods of classical mechanics, mathematical analysis and statistics were used in this study. On the basis of multifactorial experiments, the following parameters are justified: the angle of inclination of the ploughshare blade in the range of 6-70, the height and length of the guiding knife in the range of 94-110 mm and 107.2-136 mm, respectively. The main parameters of the working bodies of the machine and its technical characteristics are given. The results of the tests have established that the proposed machine for preparing the soil for sowing on the ridges reliably performs the specified technological process and its performance indicators fully meet the requirements. The use of the machine provides a reduction in operating costs for processing 1 hectare of area in comparison with the technical means used by 33.8 %.

## 1 Introduction

Currently, agrotechnical measures for preparing the soil for sowing potatoes on ridges, consisting of numerous operations of preparing the soil, leads to loss of moisture, delaying the sowing period and increasing operating costs [1-23].

Kurdyumov [26], Zykin [26], Sharonov [26], Lakhmakov [27], Mamatov [1-23], Mirzaev [4-12, 14], Aldoshin [2, 24-26], and Kodirov [6, 6] were engaged in research on the creation and use of machines for processing and preparing soil for sowing on ridges, studying their performance indicators and justifying parameters, as well as studying the processes of interaction of working bodies with the soil. These studies, on the other hand, do not go far enough in looking at the concerns of tillage for seeding potatoes while simultaneously forming ridges that provide good quality work at low energy costs.

---

\*Corresponding author: [uchqun.1277@mail.ru](mailto:uchqun.1277@mail.ru)

According to research, using a machine that performs all technological operations (surface loosening of the soil, deep loosening of the soil to a given depth, preliminary formation of ridges, and looting) can reduce fuel consumption and other costs, as well as the harmful effect of agricultural machinery on the soil, when preparing fields for sowing potatoes on the ridges.

The study's goal is to create a tillage machine that can sow potatoes while simultaneously forming ridges, resulting in high-quality tillage while conserving energy and resources.

## 2 Methods

As a result of the analysis of the literature and preliminary scientific research, the authors have developed a new technology of soil preparation in one pass for planting potatoes in the bush and a machine that implements it. The machine (Fig.1) has a frame 1 and a suspension mounted on it 2, base wheels 3, axle softener claws 4, recesses 5, left and right turning hulls 6 and 7 with a guide blade, The profile consists of 8 reels. The machine is powered by Class 3 and 4 tractors.

The frame is equipped with a spring-loaded claw, recesses and housings, and the rollers are attached to the frame by a hinged mechanism. In the process of work, the field softener claw softens the field in front of the body 15 cm wide, ie at a depth of 10 cm, and the pit softens the bottom of the formed ridge at a depth of 30-35 cm. the inverted roll forms a ridge, the profiled roller crushes the lumps, forms a soft layer, and forms the ridge completely.

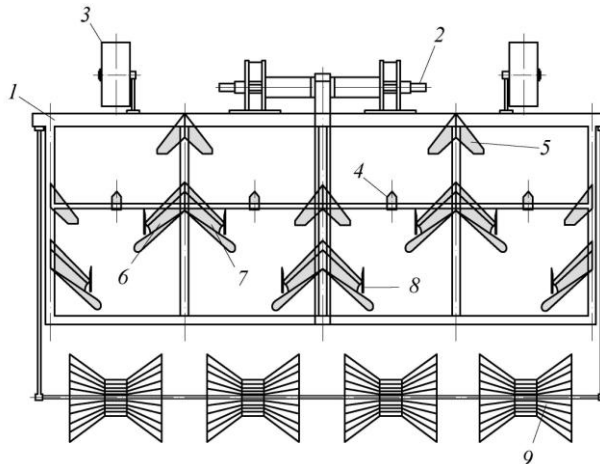

**Fig. 1.** Design diagram of the machine (top view): 1 – frame; 2 – attachment; 3 – support wheel; 4 – deep loader; 5 – pointed ripping paw; 6 and 7 – left and right-turning bodies; 8 – guide knife; 9 – ice rink

Multivariate experiments were conducted using mathematical planning of experiments to investigate the effect of the ploughshare's angle of inclination, the length and height of the guide knife, and the working speed on the traction resistance of the hulls, the degree of crumbling of the soil, and the height of the ridge.

The multivariate experiments were conducted according to the Hartley-4 plan. At the same time, the angle of installation of the ploughshare ( $X_1$ ), the height of the knife ( $X_2$ ), the length of the knife ( $X_3$ ), and the speed of the unit ( $X_4$ ) were selected as the main factors.

The assessment criteria were the height of the ridge profile ( $H$ , cm), the degree of soil crumbling ( $F$ ,%), i.e. the amount of fraction with a size of less than 50 mm and the traction resistance of the working body ( $R$ , kN).

The data obtained as a result of multivariate experiments were processed according to the PLANEX program. At the same time, the Cohren criterion was used to estimate the variance of adequacy, the Student criterion was used to estimate the values of coefficients, and the Fisher criterion was used to evaluate the adequacy of regression models.

### 3 Results

As a result of the experiments, the following regression equations were obtained that adequately describe the evaluation criteria:

- by the height of the ridge, ( $H$ , cm)

$$H=24,59-0,755X_1+0,95X_2-1,8X_3-1,2X_4+0,137X_1^2-0,631X_1X_2+0,244X_1X_3+0,281X_1X_4-1,038X_2^2+0,538X_2X_3+0,35X_2X_4+0,437X_3^2+0,887X_3X_4-0,888X_4^2; \tag{1}$$

- according to the degree of crumbling of the soil ( $F$ , %)

$$\Phi=86,722-2,81X_1-1,512X_2-2,250X_3+1,862X_4-1,226X_1^1+2,919X_1X_2+1,206X_1X_3-0,775X_1X_4-8,438X_2^2-2,294X_2X_3+4,937X_2X_4+1,324X_3^2-1,5X_3X_4+0,437X_4^2; \tag{2}$$

- by the traction resistance of the working body ( $R$ ,  $\kappa N$ )

$$R=0,89-0,193X_1-0,029X_2-0,028X_3+0,023X_4+0,034X_1^2+0,025X_1X_3+0,036X_1X_4-0,056X_2^2-0,063X_2X_3-0,063X_2X_4-0,014X_3^2-0,035X_3X_4+0,017X_4^2. \tag{3}$$

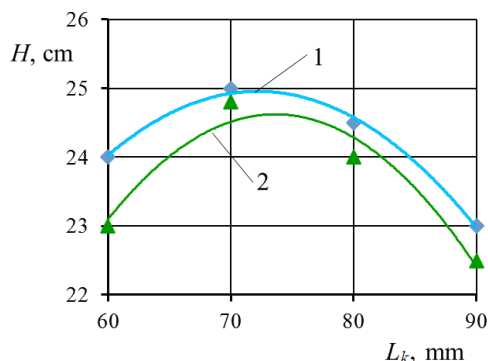

**Fig. 2.** Graphs of the height of the ridge ( $H$ ) as a function of the transverse distance between the hulls ( $L_k$ ): 1 and 2, respectively, at speeds of 6 and 9 km / h

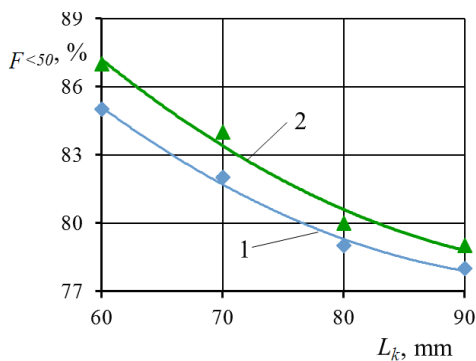

**Fig. 3.** Graphs of the degree of loosening of the soil ( $F_{<50}$ ) depending on the transverse distance between the hulls ( $L_k$ ): 1 and 2, respectively, at speeds of 6 and 9 km / h

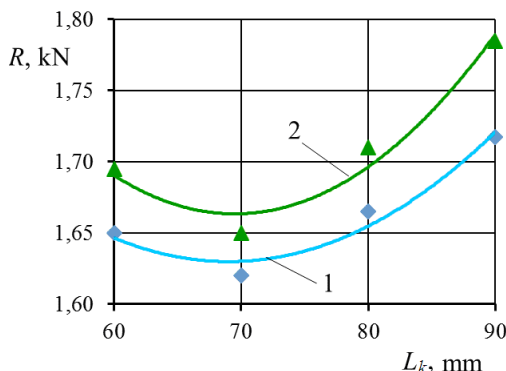

**Fig. 4.** Graphs of the dependence of the traction resistance of the hulls ( $K$ ) as a function of the transverse distance between them( $L_r$ ): 1 and 2, respectively, at speeds of 6 and 9 km/h

The analysis of the obtained regression equations showed that all factors had a significant impact on the evaluation criteria.

When determining the values of the parameters that provide the required quality of work with minimal energy consumption, the regression equations (1) and (3) were jointly solved using MS Excel and Planex programs. When solving the regression equations together, the following conditions were accepted: the criterion ( $H$ , cm), i.e. the height of the ridge should be  $24\pm 2$  cm, the criterion ( $F$ , %), i.e. the amount of fraction less than 50 mm in size should be at least 80%, and the criterion ( $R$ , kN), i.e. the traction resistance of the deep loader should have a minimum value.

The results of the conducted multifactorial experimental studies showed (Fig. 1-4) that at machine speeds of 6-9 km/h to ensure the required quality of work with minimal energy consumption, the angle of inclination of the ploughshare levi should be in the range of  $5^{\circ}45'$ - $6^{\circ}28'$ , the height and length of the guiding knife, respectively, in the range of 94-110 mm and 107.2-136 mm. These results correspond to the results of theoretical studies.

Based on the results of theoretical and experimental studies, an experimental sample of the combined machine was made (Fig. 5).

The main parameters of the working bodies of the combined machine are: the angle of entry of the deep-digger bit - $30^{\circ}$ ; the width of the bit – 8 cm, the maximum depth of processing of the deep-digger-35 cm, the height of the deep-digger-75 cm, the width of the loosening paw – 15 cm, the width of the body – 20 cm, the longitudinal distance between the body and the pointed paw – 18.5 cm, the longitudinal distance between the deep-digger and the pointed paw-20 cm, the longitudinal distance between the body and the deep-digger-11.7 cm. The working width of the developed machine is 2.8 m, the working speed is 6-9 km/h.



**Fig. 5.** General view of the machine in the unit with the Arion-630 S tractor (side view)

In one pass, the following parameters of the soil preparation machine for planting potatoes in the bush were determined: depth of cultivation; soil compaction quality; relief of ridges and ditches; the height of the ridge; weed loss rate; work productivity; fuel consumption.

The research was conducted in 2018-2019 in the Kashkadarya region of Uzbekistan in a grain field. Soil type-light loamy typical light gray. The hardness and moisture content of the soil along the horizons of 0-10, 10-20, 20-30 cm was 1.21; 1.50; 1.71; 2.12 MPa and 16.2; 17.1; 16.7; 15.9 %.

Quality indicators of the machine that prepares the soil for planting Tst 63.04:2001 "Testing of agricultural machinery. Machines and tools for surface tillage. Program and test methods", Tst 63.02:2001 " Testing of agricultural machinery. Machines and tools for deep tillage. Program and test methods" and Tst 63.03:2001 "Testing of agricultural machinery. Energy assessment methods" detected .

Tests of the soil preparation machine for planting potatoes were carried out in the fields of farms of Kashkadarya region of the Republic of Uzbekistan. In the tests, the machine was aggregated with an Arion-630 S tractor (Fig. 5).

Tests of the soil preparation machine for planting potatoes were carried out in the fields of farms of Kashkadarya region of the Republic of Uzbekistan. In the tests, the machine was aggregated with an Arion-630 S tractor (Fig. 5).

Table 1 shows the test results of the machine. The experiments were performed on fields intended for planting potatoes in early spring.

**Table 1.** Machine test results

Name of indicators	According to agrotechnical requirements	Based on the test results
Operating speed, km / h	6 - 9	7.33
Depth of soil to a pan, which impedes rooting, cm:	35 cm each	34.7
$M_{ave} \pm \sigma$	$\pm 2$	1.85
$v, \%$	<10	7.3
Depth of processing along the formed channel (bodies), cm:	$10 \pm 1$	10.4
$M_{ave} \pm \sigma$	<10	6.8
$v, \%$		
The amount of the following size fractions in the topsoil, %	< 10	8.7
> 50 mm	-	9.0
50-25 mm	> 80	82.3
< 25 mm		
The height of the ridge, cm	$24 \pm 2$	25.1
The width of the upper part of the ridge, cm	$10 \pm 1$	10.4
Width between rows, cm	$70 \pm 2$	70.6
Weed loss rate, %	>90	96.3
Fuel consumption, kg / ha	-	16.8

These data show that the performance of the machine meets the agro-technical requirements.

According to the results of the tests, the developed machine reliably performed the specified technological processes, and no serious shortcomings were observed.

According to the economic evaluation indicators, the following advantages were achieved in the use of new technology: labor costs were 2.1 hours / ha for conventional technology, 0.77 h / ha for new technology, labor cost savings were 2.7 times.

Fuel consumption was 44.97 kg/h when using conventional agricultural machinery and 16.2 kg / ha when using machinery. This shows that the reduction in fuel consumption is 2.77 times less, while the basic fuel savings for the new car's seasonal capacity is 28.77 kg/h.

Calculations carried out on the definition of technical and economic indicators of the development of machines for the preparation of soil for the cultivation of potatoes pryamie zatrati on the processing of one hectare of land reduced by 33.8%.

## 4 Conclusions

a) The following parameters of the ploughshare body and guide plate are set: the angle of inclination of the ploughshare levi in the range of 6-70, the height and length of the guiding knife, respectively, in the range of 94-110 mm and 107.2-136 mm.

- b) It is established that the proposed machine for preparing the soil for sowing on the ridges reliably performs the specified technological process and its performance indicators fully meet the requirements.
- c) The use of a machine developed on the basis of the conducted research for tillage when preparing it for sowing potatoes on ridges, reduces the direct (operational) costs of processing 1 hectare of area in comparison with the technical means used by 33.8 %.

## References

1. F. M. Mamatov, E. Eshdavlatov, A. Suyunov, The Shape of the Mixing Chamber of the Continuous Mixer, *J Adv Research in Dynamical & Control Systems* **12**, 2016-2023 (2020)
2. F. Mamatov, I. Ergashev, S. Ochilov, X. Pardaev, Traction Resistance of Soil Submersibility Type "Paraplau", *J Adv Research in Dynamical & Control Systems* **12**, 2154-2161 (2020)
3. N. Aldoshin, F. Mamatov, I. Ismailov, G. Ergashov, Development of combined tillage tool for melon cultivation, *In Proceedings: 19<sup>th</sup> International Conference on Engineering for Rural Development*, Jelgava (2020)
4. U. Umurzakov, B. Mirzaev, F. Mamatov, H. Ravshanov, S. Kurbonov, A rationale of broach-plow's parameters of the ridge-stepped ploughing of slopes, *IOP Conf. Series: Earth and Environmental Science* **403**, 012163 (2019)
5. B. Mirzaev, F. Mamatov, D. Chuyanov, X. Ravshanov, G. Shodmonov, R. Tavashov, X. Fayzullayev, Combined machine for preparing soil for cropping of melons and gourds, *IOP Conf. Ser.: Earth Environ. Sci.* **403**, 012158 (2019)
6. B. Mirzaev, F. Mamatov, I. Ergashev, H. Ravshanov, Sh. Mirzaxodjaev, Sh. Kurbanov, U. Kodirov, G. Ergashev, Effect of fragmentation and pacing at spot ploughing on dry soils, *E3S Web of Conferences* **135**, 01065 (2019)
7. F. Mamatov, B. Mirzaev, M. Shoumarova, P. Berdimuratov, D. Khodzhaev, Comb former parameters for a cotton seeder, *International Journal of Engineering and Advanced Technology* **9**, 4824-4826 (2019)
8. F. Mamatov, B. Mirzaev, Z. Batirov, S. Toshtemirov, O. Tursunov, L. Bobojonov, Justification of machine parameters for ridge forming with simultaneous application of fertilizers, *IOP Conf. Series: Materials Science and Engineering* **883**, 012165 (2020)
9. B. Mirzaev, F. Mamatov, I. Avazov, S. Mardonov, Technologies and technical means for anti-erosion differentiated soil treatment system, *E3S Web of Conferences* **97**, 05036 (2019)
10. N. Aldoshin, O. Didmanidze, B. Mirzayev, F. Mamatov, Harvesting of mixed crops by axial rotary combines, *In Proceedings: 7<sup>th</sup> International Conference on Trends in Agricultural Engineering*, Prague, Czech Republic, 20-26 (2019)
11. B. Mirzaev, F. Mamatov, N. Aldoshin, M. Amonov, Anti-erosion two-stage tillage by ripper, *In Proceedings: 7<sup>th</sup> International Conference on Trends in Agricultural Engineering*, Prague, Czech Republic, 391-396 (2019)
12. B. Mirzaev, F. Mamatov, I. Ergashev, Y. Islomov, B. Toshtemirov, O. Tursunov, Restoring degraded rangelands in Uzbekistan, *Procedia Environmental Science, Engineering and Management* **6**, 395-404 (2019)
13. Z. U. Uzakov, F. M. Mamatov, O. Begulov, Implementation of object-oriented Programming technology in the one-dimensional oil displacement problem, *International Conference on information Science and Communications Technologies*, Tashkent, Uzbekistan (2019)

14. F. Mamatov, B. Mirzaev, P. Berdimuratov, Kh. Turkmenov, L. Muratov, G. Eshchanova, The stability stroke of cotton seeder moulder, *IOP Conf. Series: Materials Science and Engineering* **883**, 012145 (2020)
15. F. Mamatov, B. Mirzaev, O. Tursunov, A Justification of Broach-Plow's Parameters of the Ridge-Stepped Ploughing, *E3S Web of Conferences* **97**, 05035 (2019)
16. B. J. Ahmedov, B. S. Mirzaev, F. M. Mamatov, D. A. Khodzhaev, M. K. Julliev, Integrating of gis and gps for ionospheric perturbations in d- And f-layers using vlf receiver, *InterCarto, InterGIS* **26**, 547-560 (2020)
17. F. Mamatov, B. Mirzaev, O. Tursunov, S. Ochilov, D. Chorlieva, Relief, physico-mechanical and technological properties of soil in the cotton growing area, *IOP Conf. Series: Earth and Environmental Science* **614**, 012169 (2020)
18. Z. Shamsutdinov, Sh. Ubaydullaev, N. Shamsutdinov, B. Mirzaev, F. Mamatov, N. Chorshabiyev, The concept of the phytogenic field: theory, research experience and practical significance, *IOP Conf. Series: Earth and Environmental Science* **614**, 012164 (2020)
19. U. Umurzakov, F. Mamatov, N. Aldoshin, B. Mirzaev, Exploration of tillage technologies in the Republic of Uzbekistan, *IOP Conf. Series: Earth and Environmental Science* **614**, 012168 (2020)
20. F. Mamatov, N. Aldoshin, B. Mirzaev, H. Ravshanov, Sh. Kurbanov, N. Rashidov, Development of a frontal plow for smooth, furless plowing with cutoffs, *IOP Conf. Series: Materials Science and Engineering* **1030**, 012135 (2021)
21. F. Mamatov, B. Mirzaev, Sh. Mirzahodzhaev, Z. Uzakov, D. Choriyeva, Development of a front plow with active and passive working bodies, *IOP Conf. Series: Materials Science and Engineering* **1030**, 012164 (2021)
22. F. M. Mamatov, E. Eshdavlatov, A. Suyuno, Continuous Feed Mixer Performance, *Journal of Advanced Research in Dynamical and Control Systems* **12**, 2195-2200 (2020)
23. F. Mamatov, I. Ergashev, B. Mirzaev, X. Pardaev, D. Chorlieva, Research of the Penetration Process of the Frontal Plow, *Journal of Physics: Conference Series* **1779**, 012002 (2021)
24. F. M. Mamatov, U. I. Kodirov, Energy-recourse machine for preparing soil for planting root crops on ridges, *European Science Review* **11**, 125-126 (2016)
25. U. Kodirov, N. Aldoshin, Sh. Ubaydullayev, E. Sharipov, Z. Muqimov, B. Tulaganov, The soil preparation machine for seeding potatoes on comb, *IOP Conf. Series: Materials Science and Engineering* **883**, 012143 (2020)
26. V. I. Kurdyumov, E. S. Zykin, I. A. Sharonov, Optimization of constructive pairs of meters of the combing machine of a row cultivator, *News of the International Academy of Agricultural Education, Sankt-Petersburg* (2013)
27. V. S. Lahmakov, Preparing the soil with cutting ridges for potatoes with a combined machine, Candidate of Technical Science Dissertation, Minsk (1989)