

Study on mechanisms of tillage for melon cultivation under the film

Khayriddin Fayzullaev^{1*}, Farmon Mamatov^{1,3}, Bakhadir Mirzaev², Dilmurod Irgashev¹, Sodik Mustapakulov¹, and Akram Sodikov¹

¹Karshi Engineering Economics Institute, 180100, Karshi, Uzbekistan

²Tashkent Institute of Irrigation and Agricultural Mechanization Engineers, 100000, Tashkent, Uzbekistan

³Karshi branch of Tashkent Institute of Irrigation and Agricultural Mechanization Engineers, 180119, Karshi, Uzbekistan

Abstract. The aim of the study is to develop a machine for preparing the soil for sowing melons under a tunnel film. The authors have developed a machine for preparing the soil for sowing melons under a tunnel film, which is equipped with deep-diggers with an inclined stand of the "paraplau" type, a furrow maker and rotary working bodies. A design diagram and a fragment of the machine operation have been given. The basic principles and methods of classical mechanics, mathematical analysis and statistics were used in this study. Tests have established that the developed machine reliably performs the specified technological process and its performance indicators fully meet the requirements. When using the developed machine for preparing the soil for sowing melons under the film, the direct cost of processing one hectare of area is reduced by 33.4%. The study's goal is to create a machine that prepares soil for seeding melons under a tunnel film. The authors have created a machine that includes deep-diggers with a "paraplau" style inclined platform, a furrow maker, and rotating working bodies for preparing the soil for planting melons beneath a tunnel film. A design schematic as well as a portion of the machine functioning has been provided. In this work, the fundamental concepts and methodologies of classical mechanics, mathematical analysis, and statistics were employed. The created machine reliably executes the required technical procedure, and its performance indicators completely fulfill the criteria, according to tests. The direct cost of processing one hectare of land is lowered by 33.4 percent when utilizing the developed machine to prepare the soil for growing melons beneath the film.

1 Introduction

The development of aggregates for combining various operations for the cultivation of melons has become possible due to the creation of an appropriate technical and economic base: equipping the agriculture of Uzbekistan with energy-saturated tractors, that is, obtaining the necessary mobile energy sources of high power; improving the quality of manufacturing parts, components and aggregates, the use of high-quality metals and polymers for the manufacture of agricultural machines and aggregates; providing agriculture with high-quality materials (seeds and fertilizers). With the introduction of combined aggregates, the problem of reducing the number of passes of agricultural machines through the field will be solved; therefore, the problem of reducing excessive compaction of the soil by the wheels of energy and technological machines will also be solved. Numerous studies in our country and abroad show [1, 4, 7, 9], that one of the many causes of wind erosion of the soil is the destruction of its wheels by energy and technological machines as a result of multiple passes of aggregates. Despite the relevance, the issue of reducing the number of passes of aggregates and the number of soil treatments during the cultivation of melon crops has not been sufficiently studied.

Modern agricultural production in Uzbekistan requires solving the problems of increasing the yield of melons, preserving effective and potential soil fertility on the basis of resource-saving soil protection technologies that provide complex mechanization of all technological operations [1-23]. The most important link in the system of cultivation of melons is tillage. Success largely depends on the timing and quality of the work, the perfection of the machine design. Mamatov [1, 3, 7, 9, 13], Aldoshin [3, 10, 11, 19, 20], Ismoilov [3], Mirzaev [4-12, 14], Chuyanov [5], and Fayzullaev [2, 24-27], Engdawork and Bork [28], and Asoegwu [29] conducted studies on various designs of working bodies and design schemes of tillage machines for melon cultivation. However, these studies have not sufficiently studied the issues of improving the tillage machines of melon cultivation for rain-fed agriculture.

The purpose of the study is to develop a tillage machine that prepares the soil for sowing melons under a tunnel film.

2 Methods

A tillage machine based on deep-drilling working bodies of the "paraplau" type, designed to prepare the soil for

* Corresponding author : xfayzullayev77@mail.ru

sowing melons, has been developed. Machining machine (Fig.1) frame 1 and mounted suspension 2, wheels 3, axle claw 4, right and left pair of pits 5 and 6, beam 7, parallelogram mechanism 8, rotary worker the organ consists of 9. The processing machines are aggregated with Class 2 tractors.

The frame is fixed to the frame by means of an axial claw, recesses and a trench (fixed) the rotating working body is hinged (movable) by means of parallelogram mechanisms. During the work, the pavement softens the cultivated strip to a depth of 8-10cm, the furrows soften the planting zone, the furrow forms an irrigation ditch, and the rotary softeners soften the top of the buds along the seed or seedling line, in which a soft layer forms.

The machine prepares the entire tunnel to be planted with seedlings in one pass through the field.

To study the transverse and longitudinal distance between deep drillers, as well as the working speed on their traction resistance and the degree of soil crumbling, experiments were conducted to justify the mutual location of deep drillers. At the same time, the longitudinal (X_1) and transverse (X_2) distance between the deep drillers, the processing depth (X_3) of the deep drillers, as well as the speed of the unit (X_4) were chosen as the main factors.

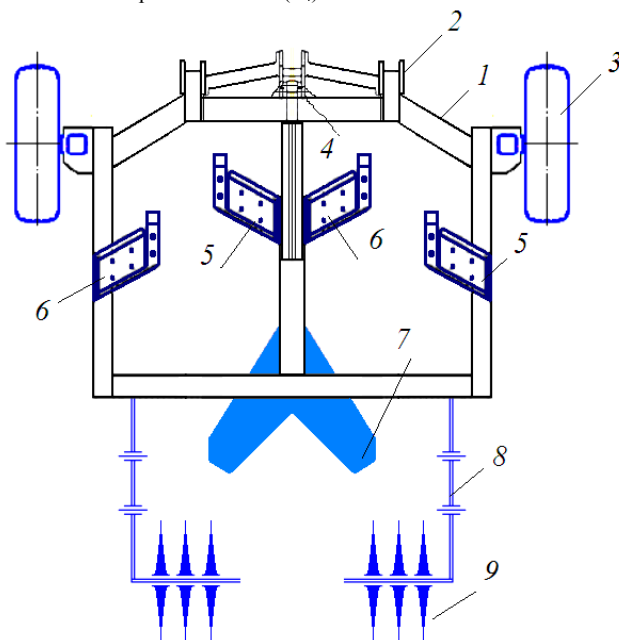

Fig.1. Constructive scheme of the tillage tool (view from above): 1 – frame; 2 – hanging device; 3 – base wheels; 4 – story claw; 5 and 6 – left and right pits; 7 – drain; 8 – parallel mechanism; 9 – rotary working body

The degree of soil crumbling (Y_1), that is, the amount of fraction less than 50 mm in size and the traction resistance (Y_2) of deep-diggers were taken as evaluation criteria.

Processing of the results was processed according to the "PLANEX" program. At the same time, the Cohren criteria were used to assess the adequacy variance, the Student's criterion was used to assess the values of the coefficients, and the Fisher criterion was used to assess the adequacy of regression models.

The experimental results were processed according to the specified procedure and the following dependencies were obtained:

- by loosening the soil (%):

$$Y_1 = 82,501 + 5,507 X_1 - 2,960 X_2 - 0,917 X_3 + 5,100 X_4 - 2,718 X_1^2 + 1,562 X_1 X_2 + 1,121 X_1 X_4 + 1,715 X_2^2 - 0,471 X_2 X_3 - 2,813 X_2 X_4 - 2,518 X_3^2 + 0,965 X_4^2; \quad (1)$$

- according to the specific traction resistance of the deep loader (κN):

$$Y_2 = 6,467 - 1,122 X_1 - 0,853 X_2 + 1,480 X_3 + 0,515 X_4 + 0,681 X_1^2 - 0,124 X_1 X_2 + 0,198 X_1 X_3 - 0,049 X_1 X_4 + 1,173 X_2^2 - 0,577 X_2 X_3 - 0,449 X_2 X_4 - 0,341 X_3^2 + 0,103 X_3 X_4 + 0,324 X_4^2. \quad (2)$$

3 Results and Discussions

The analysis of the obtained results showed that all the parameters had a significant impact on the evaluation criteria. When determining the values of the optimal parameters, the regression equations (1) and (2) were solved together using the MS Excel and Planex programs. When solving the regression equation together, the following conditions

were accepted: criterion Y_1 , that is, the amount of fraction less than 50mm in size should be at least 80%, as well as criterion Y_2 , that is, the traction resistance of the deep loader should have a minimum value. It was found that at a processing depth of 25-33cm, the longitudinal distance between the paired deep dryers should be within 75-78cm, and the transverse distance should be within 55-61cm. Based on the results of theoretical and experimental studies, an experimental sample of a combined machine was made (Fig.4).

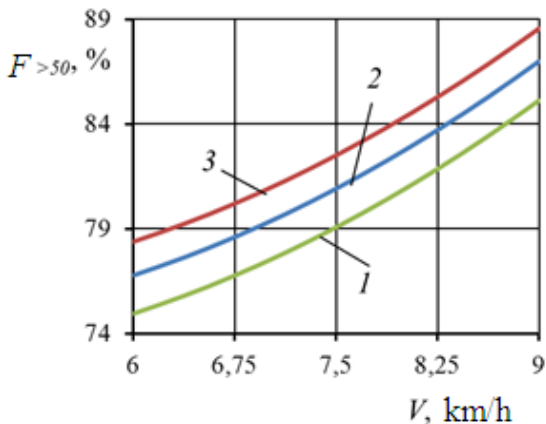

Fig.2. Dependence plot of soil crumbling on pre-sowing speed: 1, 2 and 3, respectively, at a depth of 25, 29 and 33 cm

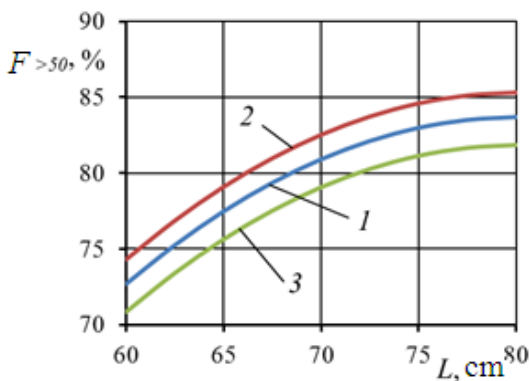

Fig.3. Plots of soil crumbling as a function of longitudinal spacing of no-till tools: 1, 2 and 3, respectively, at a depth of 25, 29 and 33 cm



Fig.4. General view of the combined machine in the unit with the tractor T 100 A(side view)

The main parameters of the working bodies of the combined machine are: the angle of entry of the deep-dredger bit 200; the width of the bit 5 cm, the maximum depth of processing of the deep-dredger 35cm, the height of the deep-dredger 75cm, the longitudinal distance between the deep-dredger and the pointed foot 40cm, the transverse distance

between the deep-dredger and the support wheel 10cm, the longitudinal distance between the deep-dredger and the furrow cutter 50.6cm, the longitudinal distance between the furrow cutter and the rotary working body 123 cm. The working width of the developed machine is 1.4m, the depth of tillage is 30-35cm, working speed is 6-9km/h. In one passage, the following parameters of the soil preparation machine, which prepares the field for planting melons, were identified: depth of cultivation; quality of soil compaction; relief of the planting area; width and depth of irrigation ditches; work productivity; fuel consumption.



Fig. 5. Fragment of the combined machine operation

Table 1. Combined machine test results

| Name of indicators | According to agrotechnical requirements | Based on the test results |
|---|---|---------------------------|
| Operating speed, km / h | 6 - 9 | 7.3 |
| Depth of planting area (pits), cm: M_{ave} , $\pm\sigma$ v ; % | from 30 cm to 35 cm ± 2 <10 | 33.4 1.6 6.2 |
| The amount of the following size fractions in the soil of the area treated by the pits, % > 50 mm 50-25 mm < 25 mm | < 10 - > 80 | 9.1 9.8 81.1 |
| Depth of irrigation ditch, cm | 25 ± 3 | 24.9 |
| Width of the irrigation furrow, cm | 50 ± 3 | 50.4 |
| Fuel consumption, kg / ha | no information | 10.5 |

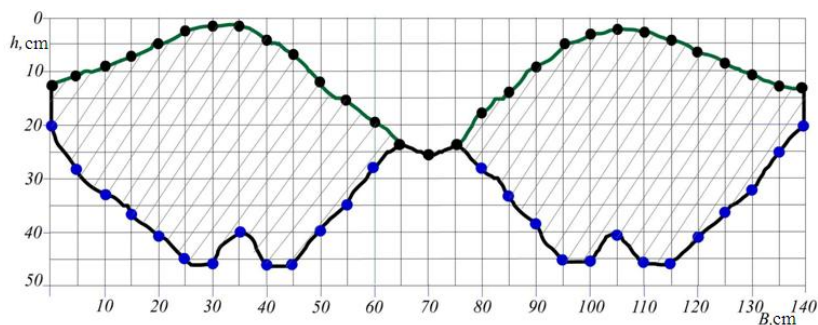

Fig. 6. Cross-section profile of the field after processing by the machine

The research was conducted in 2018-2019 in the Kashkadarya region of Uzbekistan on bogar. The type of soil is a typical light gray earth. The hardness and humidity of the soil along the horizons of 0-10, 10-20, 20-30 cm was 1.87; 1.19; 1.92; 2.33 MPa and 17.9; 17.7; 17.5; 16.9 %.

The technical characteristics are determined by the "Tests of agricultural machinery. Machines and tools for surface tillage. Program and test methods", "Testing of agricultural machinery. Machines and tools for deep tillage. The program and test methods" and "Tests of agricultural machinery. Methods of energy assessment".

In the tests, the machine was aggregated with a TL 100A tractor (Figure 5). Table 1 shows the results of the combined machine tests. The trials were conducted in the fields intended for planting melons in early spring (Fig.5).

These data show that the performance of the combined machine meets the agro-technical requirements.

The combined machine developed in the tests performed the specified technological process completely and reliably, and the test results fully meet the requirements.

Calculations show that the use of a combined field preparation machine for planting melons under a closed tunnel film reduces the direct (operating) costs per 1 hectare by 33.4%.

4 Conclusions

The test results have established that the developed machine reliably performs the specified technological process and its performance indicators fully meet the requirements.

The use of a tillage machine for sowing melons developed on the basis of research for tillage during preparation provides a reduction in direct costs for processing 1 hectare of area by 33.4 %.

References

1. F. M. Mamatov, E. Eshdavlatov, A. Suyunov, The Shape of the Mixing Chamber of the Continuous Mixer, *J Adv Research in Dynamical & Control Systems* **12**, 2016-2023 (2020)
2. F. Mamatov, I. Ergashev, S. Ochilov, X. Pardaev, Traction Resistance of Soil Submersibility Type "Paraplau", *J Adv Research in Dynamical & Control Systems* **12**, 2154-2161 (2020)
3. N. Aldoshin, F. Mamatov, I. Ismailov, G. Ergashov, Development of combined tillage tool for melon cultivation, In Proceedings: 19th International Conference on Engineering for Rural Development, Jelgava (2020)
4. U. Umurzakov, B. Mirzaev, F. Mamatov, H. Ravshanov, S. Kurbonov, A rationale of broach-plow's parameters of the ridge-stepped ploughing of slopes, *IOP Conf. Series: Earth and Environmental Science* **403**, 012163 (2019)
5. B. Mirzaev, F. Mamatov, D. Chuyanov, X. Ravshanov, G. Shodmonov, R. Tavashov, X. Fayzullayev, Combined machine for preparing soil for cropping of melons and gourds, *IOP Conf. Ser.: Earth Environ. Sci.* **403**, 012158 (2019)
6. B. Mirzaev, F. Mamatov, I. Ergashev, H. Ravshanov, Sh. Mirzaxodjaev, Sh. Kurbanov, U. Kodirov, G. Ergashev, Effect of fragmentation and pacing at spot ploughing on dry soils, *E3S Web of Conferences* **135**, 01065 (2019)
7. F. Mamatov, B. Mirzaev, M. Shoumarova, P. Berdimuratov, D. Khodzhaev, Comb former parameters for a cotton seeder, *International Journal of Engineering and Advanced Technology* **9**, 4824-4826 (2019)
8. F. Mamatov, B. Mirzaev, Z. Batirov, S. Toshemirov, O. Tursunov, L. Bobojonov, Justification of machine parameters for ridge forming with simultaneous application of fertilizers, *IOP Conf. Series: Materials Science and Engineering* **883**, 012165 (2020)
9. B. Mirzaev, F. Mamatov, I. Avazov, S. Mardonov, Technologies and technical means for anti-erosion differentiated soil treatment system, *E3S Web of Conferences* **97**, 05036 (2019)
10. N. Aldoshin, O. Didmanidze, B. Mirzayev, F. Mamatov, Harvesting of mixed crops by axial rotary combines, In Proceedings: 7th International Conference on Trends in Agricultural Engineering, Prague, Czech Republic, 20-26 (2019)
11. B. Mirzaev, F. Mamatov, N. Aldoshin, M. Amonov, Anti-erosion two-stage tillage by ripper, In Proceedings: 7th International Conference on Trends in Agricultural Engineering, Prague, Czech Republic, 391-396 (2019)
12. B. Mirzaev, F. Mamatov, I. Ergashev, Y. Islomov, B. Toshemirov, O. Tursunov, Restoring degraded rangelands in Uzbekistan, *Procedia Environmental Science, Engineering and Management* **6**, 395-404 (2019)
13. Z. U. Uzakov, F. M. Mamatov, O. Begulov, Implementation of object-oriented Programming technology in the one-dimensional oil displacement problem, *International Conference on information Science and Communications Technologies*, Tashkent, Uzbekistan (2019)
14. F. Mamatov, B. Mirzaev, P. Berdimuratov, Kh. Turkmenov, L. Muratov, G. Eshchanova, The stability stroke of cotton seeder moulder, *IOP Conf. Series: Materials Science and Engineering* **883**, 012145 (2020)
15. F. Mamatov, B. Mirzaev, O. Tursunov, A Justification of Broach-Plow's Parameters of the Ridge-Stepped Ploughing, *E3S Web of Conferences* **97**, 05035 (2019)
16. B. J. Ahmedov, B. S. Mirzaev, F. M. Mamatov, D. A. Khodzhaev, M. K. Julliev, Integrating of gis and gps for ionospheric perturbations in d- And f-layers using vlf receiver, *InterCarto, InterGIS* **26**, 547-560 (2020)
17. F. Mamatov, B. Mirzaev, O. Tursunov, S. Ochilov, D. Chorjeva, Relief, physico-mechanical and technological properties of soil in the cotton growing area, *IOP Conf. Series: Earth and Environmental Science* **614**, 012169 (2020)

18. Z. Shamsutdinov, Sh. Ubaydullaev, N. Shamsutdinov, B. Mirzaev, F. Mamatov, N. Chorshabiyev, The concept of the phytogenic field: theory, research experience and practical significance, *IOP Conf. Series: Earth and Environmental Science* **614**, 012164 (2020)
19. U. Umurzakov, F. Mamatov, N. Aldoshin, B. Mirzaev, Exploration of tillage technologies in the Republic of Uzbekistan, *IOP Conf. Series: Earth and Environmental Science* **614**, 012168 (2020)
20. F. Mamatov, N. Aldoshin, B. Mirzaev, H. Ravshanov, Sh. Kurbanov, N. Rashidov, Development of a frontal plow for smooth, furless plowing with cutoffs, *IOP Conf. Series: Materials Science and Engineering* **1030**, 012135 (2021)
21. F. Mamatov, B. Mirzaev, Sh. Mirzahodzhaev, Z. Uzakov, D. Choriyeva, Development of a front plow with active and passive working bodies, *IOP Conf. Series: Materials Science and Engineering* **1030**, 012164 (2021)
22. F. M. Mamatov, E. Eshdavlatov, A. Suyuno, Continuous Feed Mixer Performance, *Journal of Advanced Research in Dynamical and Control Systems* **12**, 2195-2200 (2020)
23. F. Mamatov, I. Ergashev, B. Mirzaev, X. Pardaev, D. Chorlieva, Research of the Penetration Process of the Frontal Plow, *Journal of Physics: Conference Series* **1779**, 012002 (2021)
24. K. Ravshanov, K. Fayzullaev, I. Ismoilov, D. Irgashev, S. Mamatov, Sh. Mardonov, The machine for the preparation of the soil in sowing of plow crops under film, *IOP Conf. Series: Materials Science and Engineering* **8830**, 12138 (2020)
25. Kh. Fayzullayev, S. Mamatov, M. Radjabov, Sh. Sharipov, R. Tavashov, M. Nurmanova, The quality of loosening the soil with subsoilers of the combined machine, *IOP Conf. Series: Materials Science and Engineering* **1030**, 012171 (2021)
26. I. Temirov, Kh. Ravshanov, Kh. Fayzullaev, Sh. Ubaydullaev, U. Kodirov, Development of a machine for preparing the soil for sowing melons under the film, *IOP Conf. Series: Materials Science and Engineering* **1030**, 012169 (2021)
27. Kh. Fayzullayev, D. Irgashev, S. Mustapakulov, M. Begimkulova, Raking plates of the combination machine's subsoiler, *E3S Web of Conferences* **264**, 04039 (2021)
28. A. Engdawork, H. R. Bork, Long-term indigenous soil conservation technology in the Chenchu area, southern Ethiopia: origin, characteristics, and sustainability, *Ambio* **43**(7), 932-942 (2014)
29. S. Asoegwu, A. Asoegwu, An Overview of Agricultural Mechanization and Its Environmental Management in Nigeria, *Agricultural Engineering International: the CIGR Ejournal* **9**, 1-22 (2007)