

# Cause Analysis and Solution of Boron Concentration Reduction in Three Generation Nuclear Power Passive Core Makeup Tank (CMT)

Tianzuo Qu <sup>1</sup>, Shuaishuai Li <sup>1</sup>, Jiefeng Wei <sup>1</sup>, Qishu Fang <sup>2</sup>

<sup>1</sup> Shandong Nuclear Power Company Ltd, Yantai, 265100, China

<sup>2</sup> SPIC Power Station Operation Technology (Beijing) Co., Ltd., Beijing 112209, China

**Abstract:** During the normal operation of the third-generation nuclear power plant, according to the requirements of the technical specification (TS), the CMT should be sampled every seven days, which should be controlled between 3400ppm and 4500ppm. However, due to various reasons, the boron concentration of CMT will drop abnormally. In order to meet the requirements of the technical specification, it is necessary to supplement boron to CMT frequently, which will cause a series of serious problems. Therefore, it is necessary and urgent to solve the problem of abnormal reduction of boron concentration in CMT.

**Key Words:** Core make-up water tank; Boron concentration; Drop; Solution.

## 1. PREFACE

During the power operation of the third generation nuclear power plant, the passive core make-up water tank (CMT) shall be sampled every 7 days according to the requirements of the technical specifications, which shall be controlled between 3400ppm and 4500ppm. During CMT operation, the inlet electric isolation valve is normally open, and the outlet pneumatic isolation valve is normally closed and failed to open. When the continuous internal leakage, periodic sampling and diffusion effect of the system are combined, the boron concentration of the sample at the tank sampling point near the inlet pipe (hereinafter referred to as the balance pipe) will decrease. This problem directly leads to a series of consequences. Firstly, the reduction of sampling boron concentration may lead to the failure to meet the operation limit conditions (LCO) required in the technical specifications. In order to prevent the boron concentration from being lower than the operation limit, it is necessary to supplement boron to CMT. The boron supplement operation brings two problems: first, the high concentration boron water is pushed into the primary loop, resulting in unplanned boration of the primary loop; The second is that the normal temperature water in CMT enters the high temperature zone of the balance pipe, and the temperature difference exceeds 180 °C, which causes the thermal stress fatigue accumulation of the inlet tee pipe fittings. The fatigue times that the pipeline can withstand are limited, and the fatigue limit will be reached within 3 cycles follow the first cycle water make-up frequency. The process of fatigue accumulation also

needs to bear the risk that the probability of LOCA increases gradually, while replacing fatigue sensitive components requires more outage time and higher economic cost.

Therefore, it is very necessary and urgent to solve the problem of reducing the boron concentration of CMT. It is necessary to research the dilution reason from the mechanism and solve the problem from the aspects of technical improvement, operation requirements and configuration optimization. This paper will discuss the dilution mechanism and various improvements of the operating unit.

## 2. Introduction to The Passive Core Cooling System (PXS) and the Core Replenishment Tank (CMT)

The passive core cooling system is to cool the core in an emergency situation, so that the temperature of the fuel element shell does not exceed 2000 °F, and the oxide layer of the shell does not exceed 17% of the wall thickness of the shell, and the integrity of the shell can still be maintained in the event of an accident, thereby protecting the health and safety of the public. A brief diagram is shown in Figure 1.

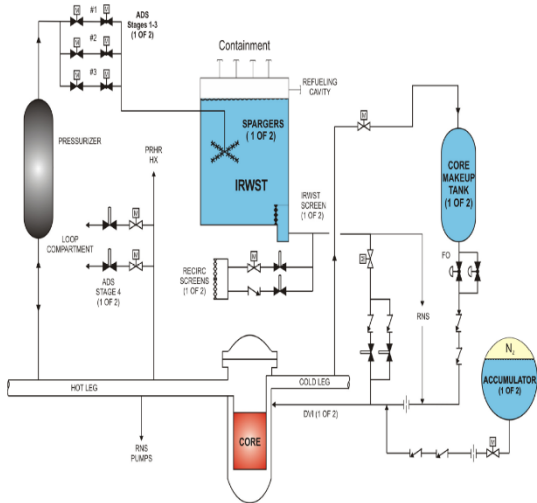

**Figure 1:** PXS passive core cooling system diagram

During an accident, CMT provided makeup and boration for the reactor coolant system (RCS) when the normal water makeup system was not available or insufficient. The two CMTs are located above the reactor coolant loop, filled with highly concentration boric acid at room temperature. In the event of a ruptured steam pipeline, the boron capacity of the two makeup tanks provides sufficient margin for reactor shutdown.

One side of the inlet balance pipe is connected to the top of the cold leg, and the other side is connected to the highest point near the inlet of the core makeup tank (Figure 2 CMT connection diagram). Under normal conditions, the balance pipe remains open to make the CMT consistent with the RCS pressure, so as to avoid water hammer when CMT starts injection, and keep the CMT pressure consistent with the RCS pressure at all times. The normal water temperature in the balance pipe is higher than that in the outlet pipe. This arrangement ensures that the water in the pressure balance pipe is hot and that CMT high concentrated boric acid can be injected into the reactor core in a way that can rely on the natural circulation of density difference. It also prevents the generation of water hammer in the pressure balance pipe in the water solid injection mode and steam injection mode.

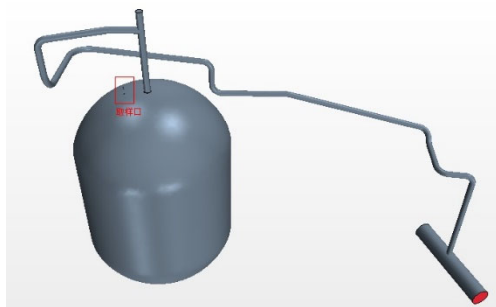

**Figure 2:** CMT connection and sampling port diagram

The outlet line at the bottom of the CMT is connected to the reactor vessel direct injection line. Once the safety injection active signal is received, the two parallel

isolation valves on the outlet pipe will open and the two CMTs will inject water into the coolant system at the same time. The concentration range of CMT boron is 3400-4500ppm; The RCS boron concentration range is about 10-1300ppm.

### 3. Cause analysis of boron concentration reduction in core makeup water tank (CMT)

#### 3.1 Proposal of boron concentration reduction in core makeup water tank (CMT)

According to the requirements of the technical specification: when the RCS integrity in modes 1, 2, 3, 4 and 5, it is necessary to confirm the CMT boron concentration every 7 days. If the sampling result is lower than 3400ppm, the power station will enter the operation limiting condition LCO, and the unit needs to recover the boron concentration within the specified time. If not, the unit needs to shutdown from the operating which will seriously affect the availability index of the safety system of the power station. The frequent boron makeup will make the CMT inlet balance tube frequently undergo large temperature sudden change transient, resulting in fatigue effect. In addition, the boron concentration in the primary loop is low at the end of the cycle. When adjusting the boron of CMT, it will cause the boration of the primary loop and induct negative reactivity, which may lead to unplanned reactor shutdown.

According to the measured value of the actual unit, the boron concentration of CMT decreases by about 40-80ppm per week. When the boron concentration approaches the lower limit, make-up water is required every one and a half months to three months.

#### 3.2 Cause analysis of boron concentration reduction in core makeup tank (CMT)

##### 3.2.1 Sampling representative verification

For upper sampling, the sampling point at the top of CMT shall be used for direct sampling. CMT sampling flow chart is shown in Figure 3.

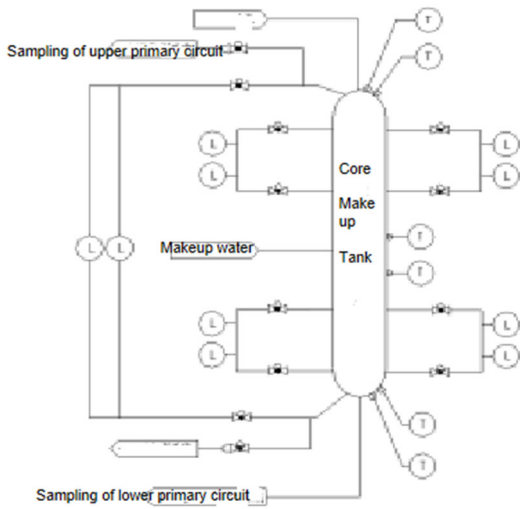

**Figure 3:** CMT sampling flow chart

For CMT sampling, a model is established.

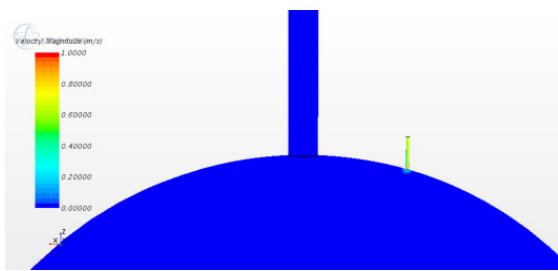

**Figure 4:** Sampling velocity scalar field

Conservative assumption of sampling speed: 2.5m/s, 0.1m<sup>3</sup> of water above the upper sampling point of CMT is much larger than the sampling volume, and there is no obvious flow from the CMT inlet to the sampling outlet. It is preliminary judged that the upper sampling can take samples representing the water quality of the upper part of CMT.

### 3.2.2 Impact analysis of low boron water introduced into RCS by sampling

Each sampling volume is 13L (3L in the upper part and 10L in the lower part). It is conservatively assumed that 13L dilution water with boron concentration of 0 enters CMT, and considering 10 times the flushing volume, the average boron concentration of CMT sampled every month will be reduced by about 27ppm (only 6ppm if only the upper sampling is considered). Under normal sampling conditions, the boron concentration will decrease slightly, but it is not the main reason.

### 3.2.3 Influence analysis of boron diffusion

Analysis of boron diffusion influence: there is concentration difference, temperature difference and gravity difference between CMT and RCS cold section, so there is a certain boron diffusion. CFD is used to analyze the effect of boron diffusion on CMT boron concentration:

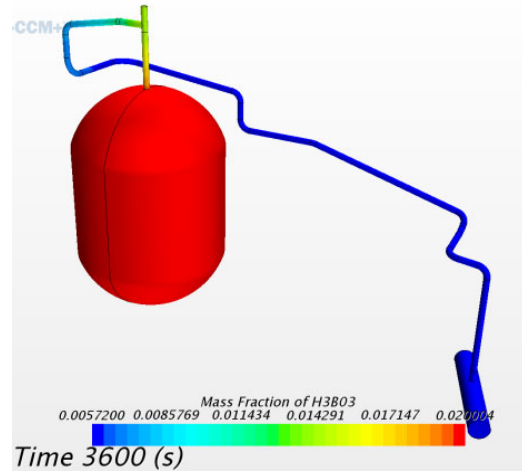

**Figure 5:** Boron diffusion versus time 3600s

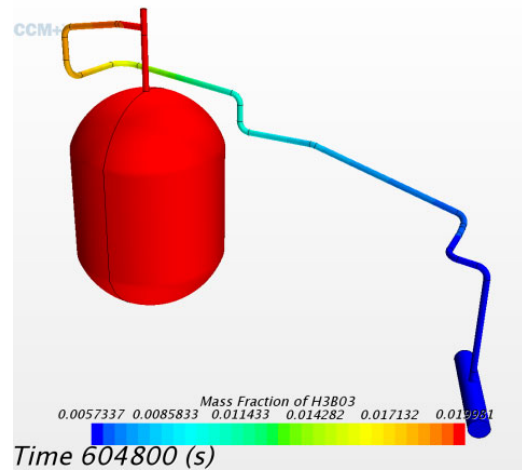

**Figure 6:** Boron diffusion versus time 604800s

After 4-8 hours, the boron concentration in the pipe between CMT and RCS has been basically balanced. Within 8 hours-7 days, the boron concentration in CMT only decreases by 1.7ppm, so the boron concentration in one month decreases by about 8ppm. Therefore, boron diffusion is one of the reasons for the decrease of boron concentration, but it is not the main reason.

### 3.2.4 Normal operation leakage impact analysis

- Manhole, temperature instrument and liquid level instrument: these leaks belong to external leakage, and no external leakage is found on site, so they can be eliminated.

- The internal leakage of CMT makeup isolation valve will cause the coolant in the balance pipe enter the CMT, resulting in the reduction of CMT boron concentration. The maximum normal leakage rate of the valve is 40ml / h.
- The CMT continuous sampling valve leakage, the coolant in the balance pipe will flow into the CMT, resulting in the reduction of CMT boron concentration. The leakage rate of sampling valve is 11ml / h.

It is conservatively assumed that if 37L (considering the normal leakage of two paths in one month) of demineralized water with boron concentration 0 enters CMT due to leakage, the average boron concentration of CMT will be reduced by about 2 ppm. Therefore, under normal leakage conditions, the boron concentration will be slightly reduced, so it is not the main reason.

### 3.2.5 Effect of abnormal leakage

The reactor coolant drain tank level was tracked during the first cycle and it was found that the level was always rising. By closing the manual valve, observe that the liquid level rises slowly, so as to know that there is abnormal leakage from CMT makeup water circuit to the isolation valve of coolant make-up water tank. After calculation, the leakage is close to 0.5l/h, which is one order of magnitude higher than the sum of leakage under normal configuration and other contributions.

Therefore, to sum up, abnormal valve leakage is the main reason for the reduction of CMT boron concentration, and the sampling of RCS low boron water, normal valve leakage and boron diffusion are the secondary contributing reasons.

## 4. Problem solving

### 4.1 Solution of valve leakage

#### 4.1.1 3.1.1 Leakage of CMT makeup isolation valve

- Check all possible leakage paths, grind the sealing pair, replace the disc / seat and replace the valve.
- CMT make-up pneumatic globe valve did not consider reverse leakage, so it was improved and replaced.
- Recheck the opening torque of the makeup valve on site. If it does not meet the requirements, it is recommended to replace the valve.

#### 4.1.2 PSS sampling valve leakage

- Check all possible leakage paths, grind the sealing pair, replace the disc / seat and replace the valve.
- Recheck the opening torque of the sampling valve on site. If it does not meet the requirements, it is recommended to replace the valve.
- Promote the localization of 3 / 8 "and below small diameter valves to ensure sufficient spare parts storage

### 4.2 The upper sampling port is moved down

The upper sampling pipeline and the upper narrow range liquid level gauge share the same nozzle. See Fig. 7 for the transformation diagram.

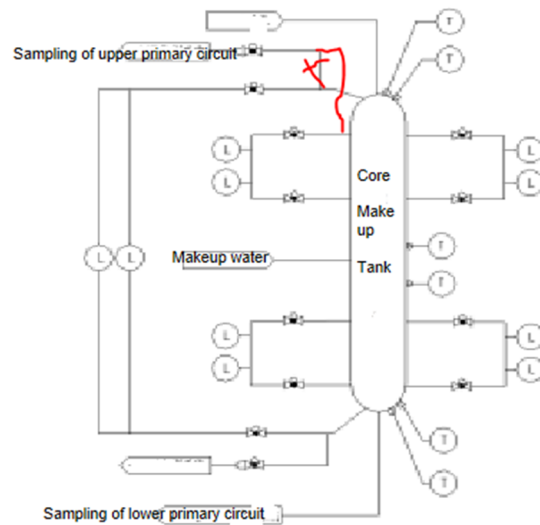

Figure 7: Downward movement of sampling port

Moving down the sampling port can ensure 25% volume margin of the water tank, that is, there is more than 17m<sup>3</sup> buffer volume for leakage and sampling before reaching this liquid level. According to the first cycle leakage rate of 400L / month, under the conservative assumption that 25% of the volume of the upper part is diluted from 4500ppm to 3400ppm, the water makeup can be less than or equal to once in the 18 month refueling cycle.

In addition, for LOCA analysis, the water volume have high requirements (the current water volume cannot be reduced), and the boron concentration requirements are insensitive (consistent with the RCS boron concentration is all right); Non LOCA analysis also have low water requirements. Therefore, moving the sampling point down to 75% of the volume of the water tank is a conservative and effective method.

### 4.3 Average sampling method

Regardless of leakage, sampling and diffusion, it does not change the continuity of boron concentration distribution in CMT. Therefore, the average value sampling method can be considered as one reliable method. the average value can be obtained by sampling from the two sampling ports at the top and bottom of the water tank, and the average value can be considered as the use value of CMT boron concentration.

This method has been verified by sampling for 14 consecutive days. It is found that the boron concentration at the bottom changes little under the combined action of leakage, sampling and boron diffusion, which can be ignored.

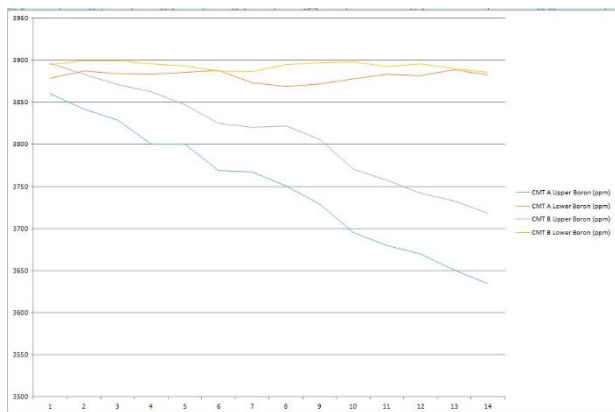

**Figure 8:** Continuous sampling boron concentration change curve at upper and lower sampling ports of CMT A / B

Through the sampling verification test, it shows that the contribution of diffusion is small. Therefore, there is stratification of boron concentration like cocktail in CMT, so the average sampling method is more conservative, and the boron concentration below the top sampling point is higher than the average value. The average sampling method can still prove that the overall boron concentration of CMT meets the safety analysis when the top sampling is 3400ppm lower than the limit. That is, when the boron concentration in the top sampling is higher than 2300ppm, the average value can be higher than 3400ppm.

#### 4.4 Extend sampling period

By tracking the leakage trend, analyze and predict the time when it reaches the operation limit. On the premise of ensuring sufficient margin, the water makeup operation can be triggered in advance. Therefore, the sampling period can be extended on this premise, so as to reduce the loss of coolant caused by frequent sampling.

#### 4.5 Evaluate the use times of sensitive parts at CMT inlet

The model used by the original designer of CMT inlet sensitive parts is too conservative, and the use times must be reviewed. By reviewing the use times, some design margins can be released, so that the unit can have more time to choose a more reasonable and effective way to solve the problem of frequent water replenishment.

### 5. Summary

For the third generation passive design, ensuring that the boron concentration of CMT does not drop abnormally is an important condition to ensure the stable operation of the unit. In this paper, the mechanism of boron concentration decline is analyzed, and different treatment schemes are formulated according to the causes. In practice, various schemes have been implemented and verified in stages, and the problem of boron concentration decline in CMT has been solved.

This paper summarizes a complete set of control and defect elimination methods in case of abnormal boron concentration change of passive equipment, which

provides a meaningful reference for subsequent passive units.

### References

1. Xiong Yi-qiang, Lin Meng, Liu Peng-fei, Yang Yan-hua, Transient Analysis on Failures of Feed Water Pump at CRP1000 Nuclear Power Station[J].Atomic Energy Science and technology,2012, 46(7):831-836
2. Wang Zhong-li. The Study on the Flowrate analysis Method for the Passive Core Makeup Tank Recirculation Test in the First AP1000 Nuclear Power Plant[J]Nuclear Science and Engineering, 2018, 38(04):546-549
3. Test Uncertainty: ASME PTC19.1, 2005[S].
4. Liao Liang, Zhou Quan-fu. CMT Injection Analysis on Loss of Normal Feedwater Flow Accident ATWS of AP1000 NPP[J] Atomic Energy Science and Technology,2011,12:1462-1465.
5. Flow Measurement: ASME PTC19.5,2004[S]