

Analysis and treatment of large-scale nuclear heating commissioning problems

Shuaishuai Li ¹, Donghai Yang¹, Tianzuo Qu ¹, Qishu Fang²

¹ Shandong Nuclear Power Company Ltd, Yantai, 265100, China

² SPIC Power Station Operation Technology (Beijing) Co., Ltd., Beijing 112209, China

Abstract. Through the modification of a nuclear power plant, the extraction steam on the exhaust pipe of the high-pressure cylinder of the steam turbine is used to heat the circulating water of the heat network, and the pressurized and heated circulating water of the heat network is supplied to the secondary thermal power station, and then supplied to various users after heat exchange, realizing the first large-scale nuclear heating in China. This paper introduces the function and process of nuclear heating system, and focuses on the analysis of the problems in the commissioning process, which provides a reference for the commissioning of other domestic nuclear power plants after nuclear heating modification.

Key words: nuclear power, heating, commissioning

1. Preface

A domestic nuclear power turbine consists of one high-pressure cylinder and three low-pressure cylinders, and four high-pressure main steam regulating combined valves are arranged on both sides of the high-pressure cylinder. The steam from steam generators of the nuclear island enters the inlet of four main steam valves through four steam inlet pipes, and then enters the high-pressure cylinder through the steam guide pipe connected with the high-pressure cylinder through four regulating valves. The high-pressure cylinder is symmetrically double split arrangement. The steam after work done by the high-pressure cylinder is discharged through the steam outlet and enters the steam inlet of the lower half of the MSR shell arranged on both sides of the steam turbine through the steam guide pipe. In this heat supply modification, two exhaust pipes in the lower half of the high-pressure cylinder are perforated for steam extraction, and the two branch pipes are combined into a main pipe, which is connected with the heat network pipe to heat the circulating water of the heat network. The circulating water of the heat network after pressurized heating is supplied to the secondary heat station, and then the hot water is sent to each community through heat exchange in the heat station.

2. Introduction to nuclear heating system and test items

Nuclear heating system includes constant pressure and make-up system of heat network, circulating water system of heat network and heating steam system of heat network.

2.1 Constant pressure and water supply system of heat supply network

The water supply and constant pressure system of the heat supply network is mainly composed of the deaerator of the heat supply network, the water supply pump of the heat supply network, pipelines, valves and instruments. Its function is to supply water to the return pipeline at the inlet of the circulating water pump of the heat supply network and maintain the pressure, so as to ensure that no vaporization will occur at any point in the heat supply network when the circulating pump of the heat supply network is stopped. A set of water supply and constant pressure system for heat supply network is set in the initial heating station, including normal water supply pipeline and emergency water supply pipeline.

The normal make-up water pipeline is also used as the constant pressure pipeline: the normal make-up water enters the deaerator through the normal make-up water valve. After deaeration, it is connected to the return water pipeline behind the circulating water filter of the heat supply network through the make-up water pump to make up water for the circulating water of the heat supply network and keep the pressure constant.

2.2 Circulating water system of heat supply network

The function of the circulating water system of the heat supply network is to pressurize the circulating return water of the heat supply network through the circulating water pump of the heat supply network, send it to the heater of the heat supply network for heating, and then supply it to the secondary heat exchange station. It mainly includes heat supply network circulating water filter, heat supply network circulating water pump, heat supply network circulating water pipeline, valves, instruments, etc. Setting of circulating water system of heat supply network $4 \times$ Variable frequency circulating water pump with 25% capacity is not used for equipment.

The return water of the circulating water of the heat supply network enters the initial heating station from the return water main pipe of the plant area. After being filtered through the circulating water filter of the heat supply network, it is pressurized by the circulating water pump of the heat supply network. After heating up in the heater of the heat supply network, the circulating water enters the municipal heating pipe network through the main water supply pipe in the plant area, and the high-temperature water is sent to the secondary heat exchange.

2.3 Heating steam system of heat supply network

The function of the heating steam system of the heat supply network is to deliver the heating steam extracted from the steam turbine to the heat supply network heater for heating the circulating water of the heat supply network during the heating period. The heating steam subsystem of heat supply network is mainly composed of steam and water heat supply network heater, pipeline, valve and instrument. The heating steam is led out from the exhaust pipe of the high-pressure cylinder of the steam turbine and supplied to two heat network heaters.

Manual isolation valve V-1, pneumatic check valve V-2 and hydraulic quick closing regulating valve V-3 are set on the steam pipeline close to the steam turbine to prevent overspeed and water inflow of the steam turbine, and the heating and steam extraction can be cut off in non heating seasons. The shutoff valve V-5 / V-6 and regulating butterfly valve V-4 / V-7 are set on the steam pipeline close to the heater to isolate and regulate the steam of the heater.

The heating steam subsystem of the heat supply network is equipped with two heat supply network heaters, each with 50% of the heat supply network load. When one heater fails, it can ensure that the heat load is not less than 60%.

The drainage of the heat supply network heater ensures that the amount of heating steam supplied by the unit is consistent with the amount of drainage from the heat supply network heater to the condenser, so as to maintain the balance of working medium. The heat supply network heater is equipped with a drainage section with a design drainage temperature of 70 °C. After the drainage of the two heat supply network heaters is incorporated into the drainage header, they return to the condenser. The flow chart is shown in Figure1.

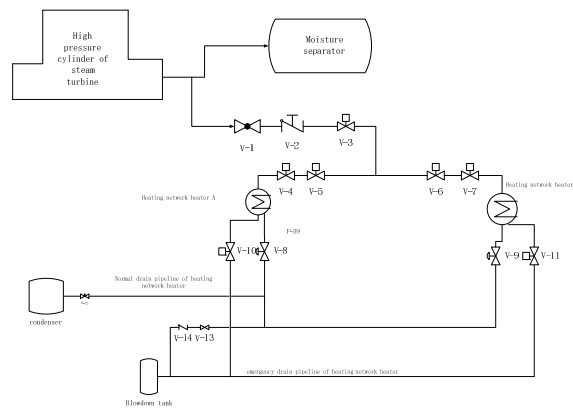

Fig. 1 flow chart of heating network heating system

2.4 Nuclear heating commissioning test items

2.4.1 water supply and constant pressure system test of heat supply network

- 1) Operation and logic interlocking test of raw water pump of heat supply network make-up system.
- 2) Commissioning of demineralized water device and verification of standby automatic switching logic.
- 3) Operation and logic interlock test of demineralized water make-up pump.
- 4) Commissioning test and logic interlocking test of deaerator.
- 5) Operation test and interlock test of water make-up pump in heat supply network.
- 6) Operation test of alkali transfer pump.

2.4.2 Test of circulating water system of heat supply network

- 1) Water injection and flushing of the system in the plant area.
- 2) Start up test of circulating water pump in heat supply network.
- 3) Continuous operation test of circulating water pump in heat supply network.
- 4) Dynamic combined flushing of circulating water pipeline of heat supply network.
- 5) Standby interlocking test of circulating water pump in heat supply network.
- 6) Constant pressure test of circulating water bypass of heat supply network.

2.4.3 Heating steam system test of heat supply network

- 1) Warm up flushing of steam extraction pipeline and heat supply network heater, water level adjustment of heater, drain switch to condenser and normal exit test of heating network heater.
- 2) Commissioning test of drainage sampling device of heat supply network.
- 3) For the quick closing test of the quick closing regulating valve in the cold state, the quick closing of the

quick closing regulating valve is realized through logic forcing, and the quick closing time is recorded.

4) Extraction check valve activity test

3. Analysis and treatment of nuclear heating commissioning problems

3.1 Alkali transfer pump does not handle

Operation test of the alkali transfer pump: open the inlet and outlet valves of the alkali transfer pump, inject alkali into the alkali transfer pipeline through the static pressure of the alkali solution tank, and then close the valve and start the pump. It is found that the pump does not treat and the liquid level of the alkali solution tank does not change. After removing the static pressure exhaust of the outlet pressure gauge of the alkali transfer pump and starting the alkali transfer pump again, the pump operates normally and the liquid level of the alkali solution tank rises normally.

3.2 The water injection pressure of circulating water pipe network cannot be established

During the water injection and flushing of the pipe network in the plant area, the high point of the pipe network continued to exhaust for a long time, but there was no continuous water flow. By comparing the cumulative water injection volume and pipe network volume calculation, the internal leakage of the isolation valve at the boundary between the plant and the external network was preliminarily judged. By using a listening needle on the valve body, the internal leakage of the valve was further established, resulting in that the pipe network had not been filled with water. By expanding the isolation boundary, there was continuous water flow at the high point of the pipe network after a period of time, and the pressure of the pipe network increased.

3.3 Abnormal operating parameters during the start-up test of circulating water pump in heat supply network

During the start-up test conducted by the bypass of the circulating water pump test, the tester ensured that the parameters were within the design range by adjusting the opening of the bypass valve. After the pump frequency changed during the test, the flow and inlet and outlet pressure did not meet the expectations, resulting in low system flow, no decrease in pump inlet pressure and small increase in outlet pressure. The inspection found that due to the long-term shutdown of the system, the test bypass filter screen was blocked, and the pump operation parameters returned to normal after treatment.

3.4 Leakage of mechanical seal of circulating water pump in heat supply network

Since the initial heating station was put into operation, the water quality was poor and the turbidity did not meet the design requirements, resulting in premature wear and failure of the mechanical seal of the circulating water pump in the heat supply network and frequent water

leakage defects. Firstly a harder seal is used. Secondly the water is extracted from the industrial water pipeline in the heating station and the pipeline pumps, valves, pressure gauges and other equipment are added to provide external flushing water for the mechanical seal in the pump. After the flushing water is provided, the defect of water leakage of the mechanical seal can be solved.

3.5 Normal drain check valve v-14 cannot be opened

In the heating and flushing stage of heat supply network heater, due to the dirty heat supply network heater and its related pipelines, the drain water cannot be recovered to the condenser, so it was initially flushed to the blowdown tank through emergency drain valve V-10 / V-11. After flushing for a period of time, it is switched to the normal drain pipeline, so as to automatically maintain the liquid level of heat supply network heater through normal drain pneumatic valve V-8 / V-9 and continue to flush the heating network heater. However, after switching to the normal drainage pipeline, the liquid level suddenly increased rapidly, resulting in the isolation of the supply steam pipeline.

Through further judgment, it was preliminarily suspected that the check valve was installed reversely or the check valve cannot be pushed open due to the low initial operation pressure of the heat supply network heater. In order to verify whether it was caused by low pressure, gradually the flow of circulating water at the pipe side of the heat supply network heater was turned down and the steam pressure at the shell side of the heat supply network heater was increased. After reaching a certain pressure, the liquid level suddenly dropped, which proved that the check valve was not installed reversely. The fundamental reason was that the steam flow at the shell side was small and the circulating water flow at the pipe side was large during the initial warm-up flushing. The only steam was condensed directly in the heater of the heat supply network. The steam pressure on the shell side was small and the check valve cannot be pushed open. With the increase of steam flow, the liquid level of heating network heater returned to normal.

4. Summary

In order to meet the demand of district heating, the nuclear power unit has been modified successfully for extracting steam from the exhaust steam of high-pressure cylinder for heating circulating water to supply heating for the first time in China. This paper mainly introduces the system flow, function, main commissioning items and problems encountered during commissioning, which provides a reference for the subsequent heating modification and commissioning of other domestic nuclear power plants. Through the commissioning of the heating system, the following problems should be paid attention to in the subsequent commissioning and operation:

(1) In the initial stage of operation, the operating exhaust valves of the two rows of heat supply network heaters are not opened. It is recommended to open the operating

exhaust valves with a small opening after the shell side pressure is higher than a certain pressure.

(2) After the negative pressure is formed on the shell side of the heat supply network heater, it is more difficult to control the water level of the heater. It is easy to have a high liquid level signal on the shell side, resulting in the isolation of the steam side and water side of the heat supply network heater. It is recommended to maintain the positive pressure of the steam header in front of the heat supply network heater. When it is greater than 0.07MPa, the water level control is more stable.

(3) In the initial stage of operation, it is necessary to control the water side flow of the heater of the heat supply network as small as possible, open the heating valve and establish the positive pressure on the shell side of the heater. On the premise of maintaining positive pressure, it is necessary to gradually increase the circulating water volume and increase the steam extraction volume, finally establish the water supply temperature required by the external network, and ensure that the water side of the heater does not exceed the temperature.

References

1. Zhuang Ya-ping, ZhangZhen, ChengZhao, JiangXuan. Study on Steam Extraction Retrofitting of PWR NPP[J]. China Nuclear Power,2013.2(12): 83-86.
2. Wu Xi-zhuang, Xia Shuan. Thermo-economics Analysis for Extraction Heat Supply of AP1000 Nuclear Power Plant Unit[J]Turbine Technology, 2020.12, 62(6):475-477.
3. LYU Kai, Wang Hong-yu, Zhou Jia. Study on characteristics of power-heat-coal of co-generation units[J]. Thermal Power Generation, 2018,47(5).
4. Zhao Chong, Luo Xiang-long, Chen Ying. Analysis and comparison of co-generation heating schemes[J]. Journal of Engineering for Thermal Energy and Power, 2016,31(12).
5. Pan Hang-ping, Yang Jian-ming, Wang Chang-shuo. Operation analysis of bottom backpressure steam turbine in extraction heating[J]. Turbine Technology, 2019.61(5).