

# Power Flow and Protection Analysis of 20kV System as Zero Down Time Program Support in Semarang City Area

Jaka Windarta<sup>1\*</sup>, Nugroho Agus Darmanto<sup>1</sup>, Mohamad Dwi K<sup>1</sup>, Arya Java Y<sup>1</sup>, Muhammad Refanza D K<sup>1</sup>,

<sup>1</sup>Department of Electrical Engineering, Faculty of Engineering, Diponegoro University, Semarang, Indonesia

**Abstract.** The electricity supply reliability is very important to improve electricity supply quality to consumers. Customers in Simpang Lima area, which located in the heart of the city, expect PLN to improve electricity supply reliability around Simpang Lima area, considering that Simpang Lima is known as culinary and business center in Semarang. However, sometimes blackouts occur during busy time which cause losses. Therefore, this study was conducted on the factors that cause blackouts and the solutions used to overcome these problems. Also, this study is conducted to improve electricity supply reliability in the Simpang Lima area and to reduce ENS. Currently, Simpang Lima area is still using the spindle system with medium voltage grid. Consequently, this system will be changed to a Closed Loop system. On the other hand, there are many buildings that use huge electricity load. For instance, Departemen Industri dan Perdagangan, Bank Indonesia, Telkomsel Semarang, DPRD, and Polda Jawa Tengah buildings. These buildings possess loads between 300-400 Amperes. Thus, the electrical supply is only generated from Simpang Lima substation. There will be further problem if blackout occurs in this substation. To avoid unexpected blackouts, this area will be set with the Zero Down Time concept. Zero Down Time is the concept of a power grid that will never goes out. Later, the Simpang Lima area that still uses the Spindle medium voltage grid will be changed to a Closed Loop with medium voltage grid system. Furthermore, this area will be supplied from Simpang Lima substation and the Kalisari substation.

## 1 Introduction

The electricity supply reliability is very important to improve electricity supply quality to consumers [1]. Customers in Simpang Lima area, which located in the heart of the city, expect PLN to improve electricity supply reliability around Simpang Lima area, considering that Simpang Lima is known as culinary and business center in Semarang. However,

---

\* Corresponding author: [jakawindarta@lecturer.undip.ac.id](mailto:jakawindarta@lecturer.undip.ac.id)

sometimes blackouts occur during busy time which cause losses. Therefore, this study was conducted on the factors that cause blackouts and the solutions used to overcome these problems. Also, this study is conducted to improve electricity supply reliability in the Simpang Lima area and to reduce ENS.

This study aims to determine the quality of the electricity supply reliability in the Simpang Lima area. The research is conducted by collecting data related to the frequency and duration of disturbances that occurred in Simpang Lima area. Furthermore, an analyzation is conducted to obtain the electricity distribution network reliability in Simpang Lima area [2].

To overcome blackouts and increase reliability value, the solution is by applying the Zero Down Time network concept, which is a network concept comes without customer outages. Based on the results of the analysis with the application of the Zero Down Time network concept, the resulting reliability is 100% with the SAIDI and SAIFI values equal to zero. The attempt to increase PLN's income will be illustrated by the decrease of the ENS value after the implementation of the Closed Loop system and then selecting the conductor specifications according to the needs. Therefore, the investment costs will be used properly [1].

## 2 Literature Review

Ditjeng conducted research concerning how the Electric Power System should be operated. [1] The author focuses more on their knowledge about the electric power system operation in Indonesia, especially for electricians. Several technical terms are developed after this study conducted. However, there are inconsistency in terms of technical terms writing.

Muhammad Agus Salim [2] conducted research on *Evaluation of the Reliability of the Electric Power Distribution System Based on Service Quality*. To improve the service quality to customers, it is necessary to know the quality of previous services as components in planning for future distribution network improvements. There is also a discussion about the electricity distribution network services quality in terms of the duration of blackouts and the frequency of blackouts that occur.

SPLN 68-2 mostly discusses about regulations, configuration of the electricity distribution network and some provisions for the guarantee of the electric power distribution system [3]. Electrical reliability is very crucial, because if electricity is less reliable it can affect income or profits from selling energy to consumers because the losses caused also affect the income.

IEEE STD 1366–2003 identifies distribution reliability indices and factors that affect their calculation [4]. It includes indices, which are useful for current and further study. The indices are intended to be applied to distribution systems, substations, circuits, and defined regions. This book also provides guidance for new personnel in the reliability area and also provides tools for internal and external comparisons.

Muh. Ahsan [1] conducted research and identify the effects of the Zero Down Time network concept on the reliability of electricity in one specific area. They also identify the differences between the existing network concept and the Zero Down Time network concept.

## 3 Research Methodology

### 3.1 Block Diagram

The output that will be produced from this project is a single-line blueprint of a 20 kV Zero Down Time designed in Semarang City. This blueprint is aimed to become a guideline for

one of the Semarang City areas for making Zero Down Time system. For the Zero Down Time configuration requirements themselves are described below.

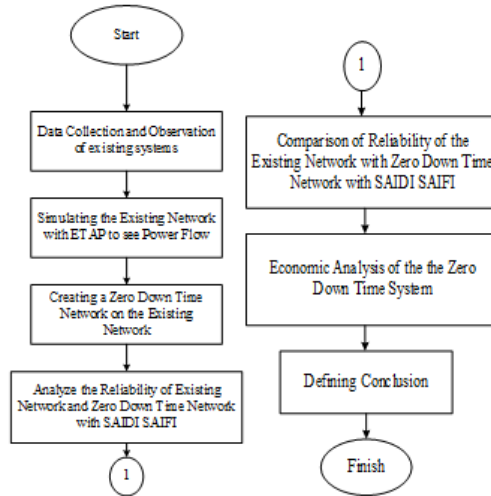

Fig. 1. Research diagram.

## 3.2 Standard of Reliability (SAIDI and SAIFI)

### 3.2.1 SAIDI

SAIDI (System Average Interruption Duration Index) is annual duration average or average length of outage each year which the result of multiplying the length of outage by the number of outages divided by the number of customers served. SAIDI generates the average blackout time data for each consumer.

$$SAIDI = \frac{\sum U_i n_i}{\sum N}$$

$\sum U_i$  = outage/interruption duration

$n$  = number of outages

$N$  = number of customers served

### 3.2.2 SAIFI

SAIFI (System Average Interruption Frequency Index) is annual average outage frequency value which can be calculated by summing the frequency of outages and customer outages then divided by the number of customers served.

SAIFI evaluates the frequency of blackouts on average times per consumer in an area. The unit is outages per customer per year.

$$SAIFI = \frac{\sum n_i}{\sum N}$$

$n_i$  = number of outages

N = number of customers served

**Table 1.** Standard Reliability Index Value SPLN 68-2:1986

<b>Konfigurasi Jaringan</b>	<b>SAIFI (Kali/Pelanggan/Tahun)</b>	<b>SAIDI (Jam/Pelanggan/Tahun)</b>
SUTM Radial	3,2	21,09
SUTM Radial dengan PBO	2,4	12,8
SKTM tanpa PPJD	1,2	4,36
SKTM dengan PPJD	1,2	3,33
SKTM dengan Gugus	0,6	1,75

The table above is a standard from PLN which is also used as our reference as a standard for a reliable electricity supply.

**Table 2.** Standard Reliability Index Value IEEE std 1366 - 2003

<b>Indikator Kerja</b>	<b>Standar Nilai</b>	<b>Satuan</b>
SAIDI	1,45	Jam/Pelanggan/Tahun
SAIFI	2,30	Kali/Pelanggan/Tahun

The table above is derived from the IEEE which is used as our reference as a standard for a reliable power supply.

### 3.3 Economy

Analysis of Economic Studies to Support the Zero Down Time Program in the Semarang City Area is carried out using a calculation formula as follows:

1. Non-premium income:  
Non-premium income = distributed kWh x regular rate
2. Platinum premium income:  
Premium income = distributed kWh x platinum premium rate
3. The income derivation in Simpang Lima area between premium and non-premium rates can be calculated with following equations:  
Difference = premium income – non premium income.
4. The increase in average annual income with the application of ZDT and premium tariffs in the Simpang Lima area can be calculated with following equations:  
One year's income difference = difference x 12 months
5. The total annual increase in income with the application of ZDT in the chemical area is:

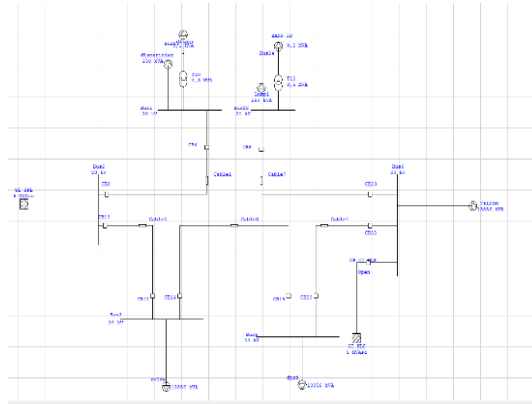

**Fig 2.** 20 kV Zero Down Time distribution network design

Total revenue = reliability revenue + premium rate revenue

ZDT network loop system that needs to be built, so the total investment cost is: Investment Cost = number of ZDT network loop systems to be built at Simpang Lima x Estimated cost to build a ZDT network loop system.

6. Taking into account the amount of investment costs to the total income obtained, from ZDT implementation / 12 months.

Total average income per month = Total income from ZDT implementation / 12 months.

7. ZDT network loop system that needs to be built, so the total investment cost is: Investment Cost = number of ZDT network loop systems to be built at Simpang Lima x Estimated cost to build a ZDT network loop system.

8. Taking into account the amount of investment costs to the total income obtained, then:

Total average income per month = Total income

Total revenue = reliability revenue + premium rate revenue

## 4 Dataset & Analysis

### 4.1 Zero Down Time System

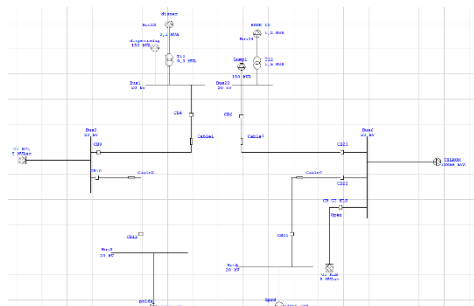

**Fig 3.** Existing Network System

The figure above describes the description of the distribution network system in the Simpang Lima area, Semarang, which gets supplies from 2 main substations, namely the Kalisari substation and the Simpang Lima substation, and there are 5 loads, namely the Disperindag building, Bank Indonesia, Telkom, DPRD, and Polda.

In the figure above, an ETAP image where Zero Down Time has been derived, it can be seen that the difference before and after Zero Down Time is applied, all loads on the ZDT

system are being supplied by 2 Substations and being applied a Closed Loop configuration. In the circuit, it flows through several areas. In Semarang, one of these areas is in Simpang Lima area. In this area the 20 kV distribution network system in Semarang City is still using the ineffective Spindle medium voltage grid system, in order to achieve Zero Down Time, especially in Semarang City. Furthermore, this will be changed close loop systems with the Load Break Switch (LBS) which will be converted into a circuit breaker at the substation added with electricity supply from other substations through the substation or to back up the power supply that is cut off in the area.

After the implementation of the Zero Down Time system, it can be seen before and after the testing, there is a disturbance and shortage in the grid network in the following ETAP simulation figure:

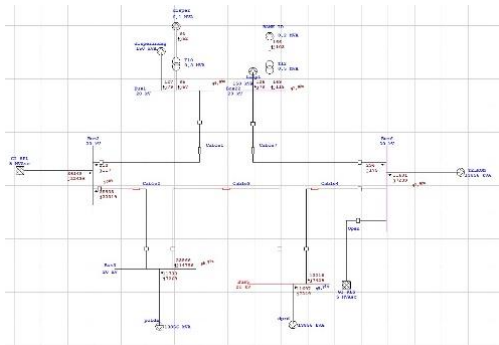

**Fig 4.** ETAP Simulation Before Shortage

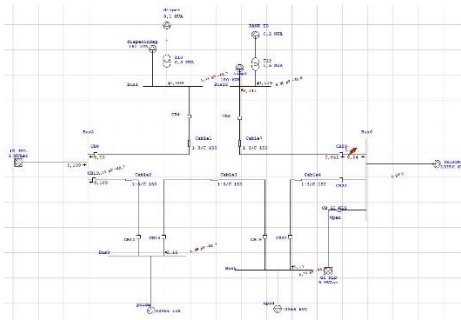

**Fig 5.** ETAP Simulation After Shortage

## 4.2 SAIDI SAIFI

The number of customers in the Simpang Lima area is calculated below.

**Table 3.** Number of customers of Simpang Lima area

No.	Substation	Customers
1	Simpang Lima	300
2	Kalisari	338
<b>TOTAL</b>		<b>638</b>

The amount of customers in the Simpang Lima area is 638 customers. According to this value, there is a huge opportunity for PLN to increase electricity sales and increase revenue with the Zero Down Time program in Simpang Lima area.

The power distribution system reliability is described as value of the ability of the electric power system to consumers. SAIDI and SAIFI value are considered as several indicators used to measure the reliability of the electric power distribution system in this study.

The following is the data on the existing outage of the substation used in this study.

**Table 4.** Existing outage of the substation

No.	Substation	$\lambda_i \cdot N_i$	$T_i \cdot N_i$
1	Simpang Lima	316	4.500
2	Kalisari	234	4.056
<b>TOTAL</b>		<b>550</b>	<b>8.556</b>

#### 4.2.1 SAIFI Calculation

- Simpang Lima System SAIFI Value equation is as follows:

$$SAIFI \text{ Simpang Lima} = \frac{\lambda_i N_i}{N}$$

$$SAIFI \text{ Simpang Lima} = \frac{316}{638}$$

$$SAIFI \text{ simpang lima} = 0,495$$

Therefore, the SAIFI value of the Simpang Lima system is 0,495 times/ customer/ year.

- Kalisari System SAIFI Value equation is as follows:

$$SAIFI \text{ Kalisari} = \frac{\lambda_i N_i}{N}$$

$$SAIFI \text{ Kalisari} = \frac{234}{638}$$

$$SAIFI \text{ Kalisari} = 0,366$$

Therefore, the SAIFI value of the Kalisari system is 0,366 times/customer/ year.

#### 4.2.2 SAIDI Calculation

- SAIDI Value of Sistem Simpang System equation is as follows:

$$SAIDI \text{ Simpang Lima} = \frac{T_i N_i}{N}$$

$$SAIDI \text{ Simpang Lima} = \frac{4500}{638}$$

$$SAIDI \text{ simpang lima} = 7.1$$

Therefore, the SAIDI value of Simpang Lima system is 7.1 minutes/customer/year.

- SAIDI Value of Kalisari System equation is as follows:

$$SAIDI \text{ Simpang Lima} = \frac{T_i N_i}{N}$$

$$SAIDI \text{ Simpang Lima} = \frac{4.056}{638}$$

$$SAIDI \text{ simpang lima} = 6.35$$

Therefore, the SAIDI value of the Kalisari system is 6.35 Minutes/Customer/Year.

## 5 Economical Value

1. Non-premium income value:  
Non-premium income =  $10.221.393 \text{ kWh} \times \text{Rp. } 1.592 = \text{Rp. } 16.272.457.656/\text{Month}$ .
2. Premium income value:  
Premium income =  $10.221.393 \text{ kWh} \times 1.722 = \text{Rp. } 17.601.238.746/\text{Month}$
3. The income deviation value in the Simpang Lima area between premium and non-premium system:  
Deviation value =  $\text{Rp. } 17.601.238.746 - 16.272.457.656 = \text{Rp. } 1.328.781.090 \text{ perMonth}$
4. The average income increase for one year with the application of ZDT and premium tariffs in the Simpang Lima area:  
One year income difference =  $1.328.781.090 \times 12 = \text{Rp. } 15.945.373.080$
5. Total increase in annual income with the application of ZDT in Simpang Lima area is:  
Total Income =  $\text{Rp. } 1.737.915.403 + 15.945.373.080 = \text{Rp. } 17.683.288.483$
6. The ZDT network loop system needs to be built, so the total investment cost is:  
Investment cost =  $2 \times 1,3 \text{ Billion} = 2,6 \text{ Billion Rupiahs}$ .
7. By prioritizing the investment costs value to the obtained total income, the calculation is as follows:
  - Total monthly average income =  $\text{Rp. } 17.683.288.483 / 12 \text{ Months} = \text{Rp. } 1.473.607.373,58$
  - Break Event Point (BEP) value value =  $\text{Rp. } 2,6 \text{ Billion} / \text{Rp. } 1.473.607.373,58 = \text{Rp. } 1,76 \text{ Billion}$ .

## Conclusion

The difference between the medium voltage grid conditions in the Simpang Lima area before using the Zero Down Time network is the Spindle network which will later be converted into a Loop Network configuration that has two substations operated in parallel. The value after applying Zero Down Time concept in the Simpang Lima area is increased with the value Rp. 17.683.288.483 per year as described: Rp. 15.945.373.080 value is obtained from alternating customer class to VIP customer; Rp. 1.737.915.403 value is obtained from eliminating customers' outage in Simpang Lima area so that the undistributed energy is equal to zero. The effect of installing a Zero Down Time network concept at Simpang Lima area can reduce blackouts due to network disturbances, with the previous SAIDI annual value from 13.45 to 10.11 hours/customer/year. Moreover, the SAIFI annual value is also decreasing to 0.54/customer/year of blackouts from 0.85/customer/year.

## References

- [1] A. Zamzami, "Skripsi analisa peningkatan keandalan kawasan industri makassar (kima) dengan konsep desain jaringan zero down time(zdt)," *Anal. Peningkatan Keandalan Kaw. Ind. Makassar Dengan Konsep Desain Jar. Zero Down Time(Zdt)*, vol. I, pp. 209–210, 2019.
- [2] M.A. Salim, "Evaluasi Keandalan Sistem Distribusi Tenaga Listrik Berdasarkan Mutu Pelayanan," pp. 45–51, 2016.
- [3] P. PLN, "Spln 68-2, 1986." 1986.
- [4] IEEE STD. 1366–2003. *IEEE Guide For Electric Power Distribution Reliability Indices*.