

# Auditing the estimated cost of construction of transport infrastructure facilities

*Maria Bovsunovskaya*<sup>1\*</sup> and *Daria Kurtina*<sup>1</sup>

<sup>1</sup>Moscow State University of Civil Engineering, 26, Yaroslavskoe shosse, Moscow, 129337, Russia

**Abstract.** The paper is devoted to the study of the audit of the estimated cost of construction of transport infrastructure facilities. Since it is the study of the estimate documentation for the correctness and accuracy of the application of prices and scope of works that makes it possible to ensure the expediency of using funds, avoid financial losses and achieve high-quality project implementation. The authors justified the need for an audit, identified its stages and their content. An algorithm for checking local estimates during an audit of the estimated cost has been compiled. Specific examples of analyzing the positions of the estimate documentation during the audit of the estimated cost of construction of transport infrastructure facilities are given, deviations in the composition of local estimates are identified, recommendations are given based on the results of the audit.

## 1 Introduction

The development of transport infrastructure in the Russian Federation according to the Russian Transport Strategy includes both modernization, reconstruction, overhaul, and new construction. The implementation of these measures requires significant capital investments, which are carried out, among other things, with the involvement of funds from the budgetary system of the Russian Federation. The amount of capital investments in reconstruction, modernization, overhaul, as well as new construction (hereinafter referred to as construction) is calculated at the stage of architectural and construction design and is called the estimated cost. In turn, the estimated cost of facilities financed by more than 50% from the budget of the Russian Federation and the cost of construction of which exceeds 10 million rubles is subject to state expertise for the reliability of the use of funds. In cases where the cost of construction does not exceed 10 million rubles, the estimated cost is checked if it is provided for by the contract.

Companies responsible for the implementation of projects for the construction of transport infrastructure are interested in internal verification of the estimated cost before passing its examination, as well as when making changes to project documentation at the stage of project implementation [1,2]. This implies the regularity of such a phenomenon as an audit of the estimated cost in the Customer's companies, which is understood as a specialized study aimed at determining the objectivity and reliability of calculated indicators, eliminating overestimation or underestimation of cost indicators for an object.

---

\* Corresponding author: [saltmasha@mail.ru](mailto:saltmasha@mail.ru)

Despite the undoubted importance of auditing the estimated cost of transport infrastructure facilities, the specific features of its implementation (methods, criteria, organization algorithm and procedure) have not yet been formulated.

## 2 Materials and methods

A construction cost audit is a fundamental element of controlling the correct use of the budget and an effective tool that shows as much as possible all capital investments made and planned for implementation, therefore, it is carried out at all stages of the life cycle of an investment and construction project (hereinafter referred to as ICP) [3,4,5]. Estimated cost audit is an integral part of the ICP implementation audit system [6,7,8].

The estimated cost of construction is determined as part of the estimate documentation, which is drawn up in a separate section of the project documentation. The cost of the object and its main solutions, types and complexes of works in Russia and in foreign countries include the following elements (formula 1) [2,9]:

$$\text{Construction cost} = \text{CIW} + \text{Equipment} + \text{Other} \quad (1)$$

CC = Construction cost,

CIW – cost of construction and installation works (including the cost of materials, products and structures; labor costs of construction workers; operation of machines and mechanisms; overhead and estimated profit),

Equipment – cost of Equipment,

Other - other costs (costs of design, surveys, preparation of the construction site, maintenance of the Customer's service, etc.).

If the financing of the construction object is carried out with whole or partial involvement of the budget system of the Russian Federation, then the approved estimated standards included in the Federal Register of Estimated Standards of the Russian Federation should be used to form the estimated cost. A set of estimates is formed, consisting of an explanatory note, bills of quantities, other supporting documents (if necessary, as well as calculations for certain types of work, local estimates, object estimates, a summary estimate of the construction costs [10,11].

The main purpose of auditing the estimated cost as part of the estimate documentation is to verify the reliability of determining the estimated cost of a particular facility and to verify the correctness of the calculations of all expenditure items for the subsequent submission of the estimate documentation to the state examination, as well as to check that the cost in the working documentation does not exceed the estimated cost taken into account in project documentation.

The main tasks of auditing the estimated cost of construction in the Customer's companies include:

1. Conducting an assessment of the consistency of the project objectives. Construction is a complex process that involves many participants, and it is necessary that the goals of all parties coincide with the overall goal of the project. This is the only way to achieve a positive final result.

2. Carrying out an assessment of compliance with the requirements of the Customer. The quality of the estimate documentation directly depends on the accuracy of the implementation of requests and customer requirements.

3. Conducting an assessment of compliance with regulatory documents is one of the most important goals of an audit, since the preparation of estimate documentation is strictly subject to legislative and regulatory documents. And deviations or inconsistencies with them can lead to huge financial losses.

4. Assessment of the validity of technical solutions. The expert also checks the feasibility of certain technical solutions, since the implementation of construction is based not only on the existing capabilities of the contractor, but also on the best practices in the construction of such facilities and scientific research in the construction industry.

5. Assessment of the use of resources. The use of resources must be timely and appropriate. It is important to exclude the irrational use of resources, both labor and material.

The audit of the estimated cost is carried out in the Customer's companies by expert estimators, who, based on the results of the audit, draw up a reasonable report in which they indicate the results of the audit.

The first stage of the verification is the analysis of the estimated cost for the subsequent submission of the estimate documentation (hereinafter – ED) to the state examination for:

- compliance with the requirements of the estimated and regulatory framework with pricing regulations applied in accordance with the Federal Register of current estimated standards;
- correctness of the application of the tariffs of the estimated and regulatory framework;
- correct attribution of costs by chapters of the consolidated estimate calculation (hereinafter referred to as CEC);
- completeness of inclusion of costs by chapters of the CEC, taking into account the incurred and planned costs on the basis of relevant documents;
- verification of the correctness of the formation of object estimates;
- correct application of estimated standards, coefficients and indices in local budget calculations;
- compliance of the volumes and scope of work specified in the bill of quantities to the volumes and scope of work specified in the local estimates;
- correct application of the coefficients in the construction of transport infrastructure facilities;
- correctness of determining the basic and current cost of material and technical resources that are not in the estimated and regulatory framework, including using the 'reverse count' method;
- correct determination of the amount of overhead costs and estimated profit in the basic and current price levels;
- correct distribution of work by sections (subsections) of the local cost estimate;
- correct location of work in local estimates according to the technological sequence of work;
- correct accounting of cost indicators by types of costs (construction, installation, other works and costs, equipment, furniture, inventory);
- correctness of arithmetic calculations.

The second stage of the audit of the estimate documentation by the expert estimator is carried out for the working documentation after its approval by the technical specialists of the Customer's service.

When auditing local estimates, the applied prices from the estimated and regulatory framework and or scope of work are clarified, followed by recalculation of the cost per line.

When adjusting the local estimate (in terms of scopes, prices, indices), the results of the local estimate are recalculated. When making adjustments to a previously issued local estimate, *Rev.1 (Rev.2, etc.)* is added at the end of the estimate number. When making partial changes with the inclusion/exclusion of certain types of work and/or material resources, an additional estimate is issued marked *Add.1 (Add.2, etc.)*. Additional estimates are considered together with the main estimate, which has the same number. When making changes to the estimates, the cost estimate expert ensures the replication of the estimate,

transfer to interested parties for further work, including in electronic format of a specialized software package for issuing estimate documentation.

After checking the estimate calculation and making the necessary adjustments, the first sheet of the estimate is stamped with the stamp “Prices and coefficients checked” with the full name of the estimate expert who checked the estimate, personal signature and current date.

### 3 Research results

The most difficult and time-consuming aspect in the audit of estimate documentation is the analysis of the compliance (not exceeding the limit) of the construction cost according to the estimate documentation as part of the working documentation (WD) to the construction cost according to the estimate documentation as part of the design documentation (DD), which received a positive conclusion from the state examination.

In the absence of costs or the excess of the cost of WD for DD, the estimate documentation is issued with a notice of no costs or with a comparative table with a detailed analysis of the reasons for the discrepancy and a notice of excess costs. A table is drawn up showing the excess of the cost of estimates of the WD stage over the cost of estimates of the DD stage.

Let's make an algorithm, on the basis of which it is possible to check local estimates (Fig. 1).

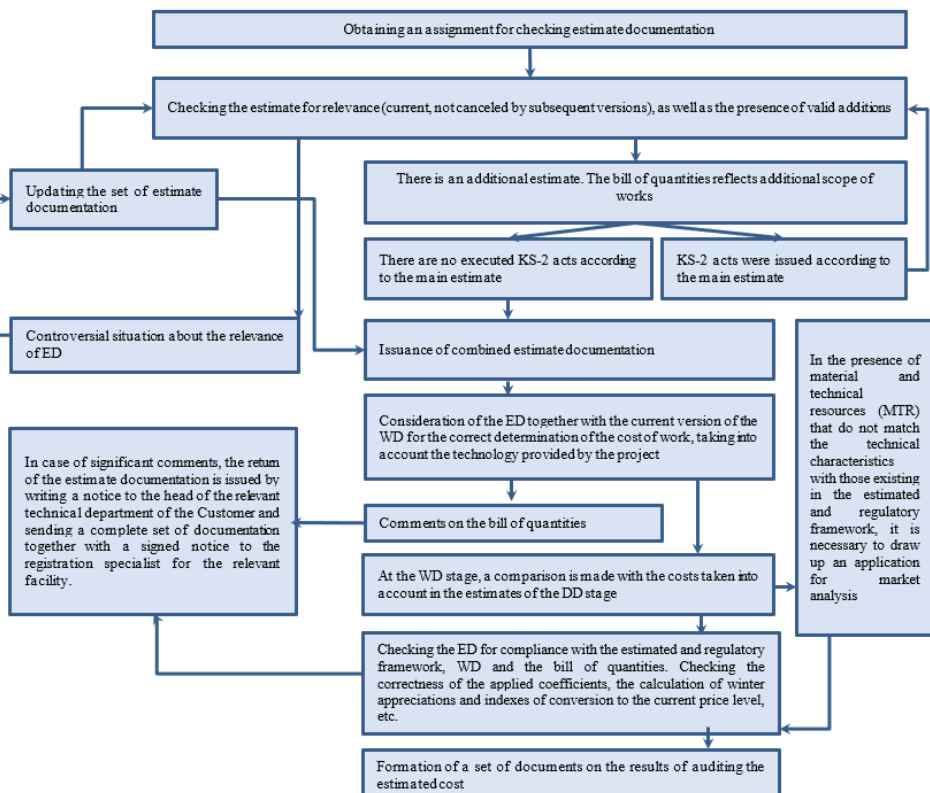

Fig. 1. Algorithm for auditing local estimates.

Upon completion of the local estimate verification, it is necessary to generate a complete set of documents in electronic form for further approval of the issued estimate by the higher management. The set includes:

- title page with explanatory notes of the design institute;
- explanatory note (if available);
- bill of quantities signed by the responsible person;
- agreed letters of the State Expertise (if available);
- notice and comparison tables;
- estimate in Sobx format;
- volume of estimate documentation of the DD stage with reference to the corresponding estimate (if available);
- if necessary, other comments and clarifications to the issued ED.

The development of estimate documentation on its own is carried out on the basis of an official request indicating the source of funding, provided that there are no costs in the WD stage. The basis for issuing a local estimate is the bill of quantities agreed by the responsible person. The completed estimate documentation is sent with a notification, a complete set of documents and an indication of the final cost of the issued estimate.

Let us consider an example of auditing the estimated cost: An audit of the estimated documentation begins with the study of project documentation, drawings and compliance, correctness of the bill of quantities. After that, the inspector proceeds to the estimate documentation itself. Let us study the first three prices of the estimate documentation (Installation of technical means of traffic management) calculated using TSN-2001 in prices for February 2022 (Table 1).

**Table 1.** Estimated paragraph before checking 1.

No.	Pricing code and resource codes	Name of works and costs	Un. Meas.	Number of units	Price per unit of meas., RUB	Correction factors	Winter appreciation coefficient	Total costs in the basic price level, RUB	Conversion coefficients (indices), norms of OH and EP	TOTAL costs in the current price level, RUB
1	2	3	4	5	6	7	8	9	10	11
<b>Section: Installation of technical means of traffic management</b>										
1	6.69-28-14	Drilling holes in building structures made of bricks with diamond drilling machines, ring diamond drill diameter 150 mm	10 cm drill penetration	31.2						
		Volume: 31.2=(26*12)/10								
		W			8.72		1.047	284.85	26.06	7 423.19
		MO			19.92		1.047	650.71	2.33	1 516.15
		incl. MW			0.45		1.047	14.70	26.06	383.08
		MR			0.39		1.002	12.19	5.18	63.14
1.1	1.7-3-43	High-performance diamond core drill bit, with quick-release shank, for all	un.	0.2652	10 495.92		1.002	2 789.09	2.73	7 614.22

		types of concrete, length 430 mm, diameter 152 mm								
		OH from W	%	91				259.21	75	5 567.3 9
		EP from W	%	70				199.40	41	3 043.5 1
		OH and EP from MW	%	175				25.73	160	612.93
		LCW	man-hour	0.6			1.047	19.60		
		<b>Total by position:</b>					<b>4 221.18</b>		<b>25 840.53</b>	
2	6.68-13-1	Mechanized loading of construction debris into dump trucks	1 t	0.25						
		MO					8.86	1.047	2.32	9.92
		incl. MW					1.48	1.047	0.39	26.06
		OH and EP from MW	%	175				0.68	160	16.26
		<b>Total by position:</b>					<b>3.00</b>		<b>39.27</b>	
3	3.27-71-1	Installation of road signs on metal racks	100 signs	0.12						
		Volume: 0.12=12/100								
		W					3 330.0 7	1.047	418.39	26.06
		MO					1 115.2 9	1.047	140.13	13.48
		incl. MW					247.94	1.047	31.15	26.06
		MR					1 181.6 8	1	141.80	3.89
3.1	1.7-13-8	Signs made of thin sheet galvanized steel with retroreflective film, square shape, with sides measuring 700 mm	un.	9	633.51			1	5 701.5 9	1.29
3.2	1.7-13-5	Signs made of thin sheet galvanized steel with reflective film, round shape, diameter 700 mm	un.	3	636.66			1	1 909.9 8	1.28
3.3	1.7-13-100	Galvanized steel posts, diameter 76 mm	m	66	191.48			1	12 637. 68	2.72
3.4	1.7-13-101	Hose clamps made of galvanized steel, diameter 76 mm	un.	24	47.28			1	1 134.7 2	1.17
		OH from W	%	80				439.31	87	9 485.8 2
		EP from W	%	55				322.16	41	4 470.3 3
		OH and EP from MW	%	175				54.51	160	1 298.8 3

		LCW	man-hour	49.5			1.047	37.42		
		<b>Total by position:</b>					<b>22 900.27</b>		<b>74 100.70</b>	

Note: W - workers' wages

MO - machine operation

MW – machinists' wages

MR - material resources

OH - overhead costs

EP - estimated profit

LCW - labor costs of workers

During the check, an error was identified: paragraph 1 (price 6.69-28-14 “Drilling holes in building structures made of bricks with diamond drilling units, the diameter of the annular diamond drill is 150 mm”), subparagraph 1.1 (price 1.7-3-43 “High-performance diamond core drill bit, with a quick-release shank, for all types of concrete, length 430 mm, diameter 152 mm”), paragraph 2 (price 6.68-13-1 “Mechanized loading of construction debris into dump trucks”) are included in the price indicated below – point 3 (price 3.27-71-1 “Installation of road signs on metal racks”). That is, these costs are double-counted in the estimate. To prevent doubling the cost of work, it is necessary to exclude the first two items from the audited estimate (Table 2).

**Table 2.** Prices for the installation of road signs after checking.

N o.	Pricing code and resource codes	Name of works and costs	Un. Meas.	Number of units	Price per unit of meas., RUB	Correction factors	Winter appreciation coefficient	Total costs in the basic price level, RUB	Conversion coefficients (indices), norms of OH and EP	TOTAL costs in the current price level, RUB
1	2	3	4	5	6	7	8	9	10	11
<b>Section: Installation of technical means of traffic management</b>										
3	3.27-71-1	Installation of road signs on metal racks	100 signs	0.12						
		Volume: 0.12=12/100								
		W			3 330.07		1.047	418.39	26.06	10 903.24
		MO			1 115.29		1.047	140.13	13.48	1 888.95
		incl. MW			247.94		1.047	31.15	26.06	811.77
		MR			1 181.68		1	141.80	3.89	551.60
3.1	1.7-13-8	Signs made of thin sheet galvanized steel with retroreflective film, square shape, with sides measuring 700 mm	un.	9	633.51		1	5 701.59	1.29	7 355.05
3.2	1.7-13-5	Signs made of thin sheet galvanized steel with reflective film, round shape, diameter 700 mm	un.	3	636.66		1	1 909.98	1.28	2 444.77
3.	1.7-13-	Galvanized	m	66	191.48		1	12 637.	2.72	34 374.

3	100	steel posts, diameter 76 mm						68		49
3, 4	1.7-13-101	Hose clamps made of galvanized steel, diameter 76 mm	un.	24	47.28		1	1 134.72	1.17	1 327.62
		OH from W	%	80				439.31	87	9 485.82
		EP from W	%	55				322.16	41	4 470.33
		OH and EP from MW	%	175				54.51	160	1 298.83
		LCW	man - hour	49.5			1.047	37.42		
		<b>Total by position:</b>						<b>22 900.27</b>		<b>74 100.70</b>

Thus, the first two prices were reasonably excluded from the estimate. Further, no errors were found in the estimate. The estimated cost for the entire estimate also decreased accordingly (Table 3).

**Table 3.** Comparison of the estimated cost of the estimate before and after the audit.

Estimate cost:	Current price, thousand rubles		Deviation (Saving)	
	Before the audit	Taking into account the audit	thousand rubles	%
1	2	3	4	5
Construction works	415.09	389.21	- 25,88	- 6.23%
Funds for wages	85.49	77.67	-7.82	- 9.15%

The estimated cost before the audit was 415.09 thousand rubles at current prices (February 2022), and after verification – 389.21 thousand rubles. That is, the difference amounted to 25.88 thousand rubles, which corresponds to the sum of excluded positions. Estimated documentation is checked, certified by the stamp of the inspector with the date of verification and sent to the technical department for further use in the work.

Next, let us consider an example from the estimate for another object - “Pedestrian crossing”. The estimate was compiled in the same way as the previous estimate by the Project Manager organization at the level of current (predicted) prices with Coefficients for TSN-2001 MGE.

During the check in paragraph 2, price 3.29-1006-1 “Drilling of mine shafts by a sinkhole”, the price for the closed method of work is applied. The pricing is shown in Table 4.

**Table 4.** Estimated paragraph 2 before checking.

N o.	Pricing code and resource codes	Name of works and costs	Un. Meas.	Number of units	Price per unit of meas., RUB	Correction factors	Winter appreciation coefficient	Total costs in the basic price level, RUB	Conversion coefficients (indices), norms of OH and EP	TOTAL costs in the current price level, RUB
1	2	3	4	5	6	7	8	9	10	11
<b>Section: Lining construction</b>										
1	3.29-1006-1	Drilling of mine shafts by a sinkhole in soils of groups	100 m3 of soil according to	0.715						



	1-2	the design outer outline							
	Volume: 0.715=(71.5)/100								
	W			5 477.21		1.047	4 100. 27	24.82	101 768. 70
	MO			10.09		1.047	7.55	7.45	56.25
	incl. MW			0.47		1.047	0.35	24.82	8.69
	MR			8 961. 37		1	6 407. 38	4.42	28 320.6 2
	OH from W	%	131				5 371. 35	122	124 157. 81
	EP from W	%	134				5 494. 36	51	51 902.0 4
	OH and EP from MW	%	175				0.61	157	13.64
	LCW	man-hour	403.6			1.047	302.14		
	<b>Total by position:</b>						<b>21 381.52</b>		<b>306 219.06</b>

For a more visual representation of the work, consider the drawing (Fig. 2 and Fig. 3).

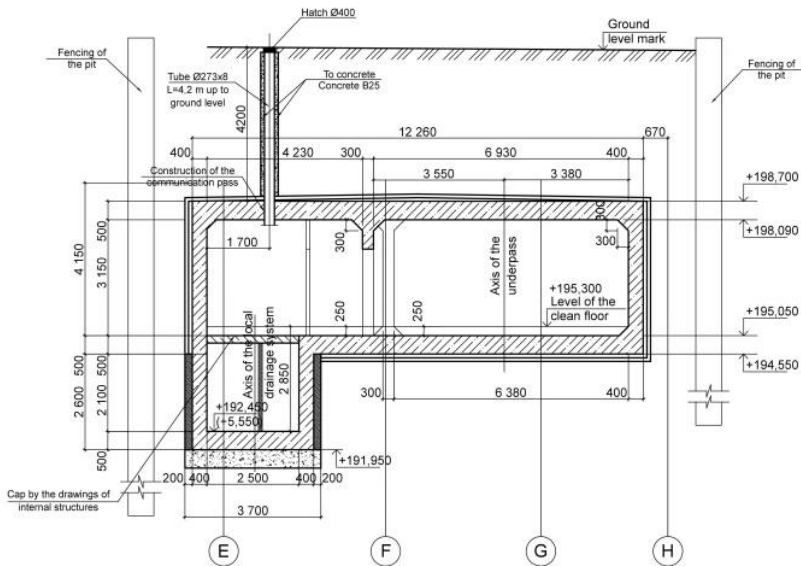
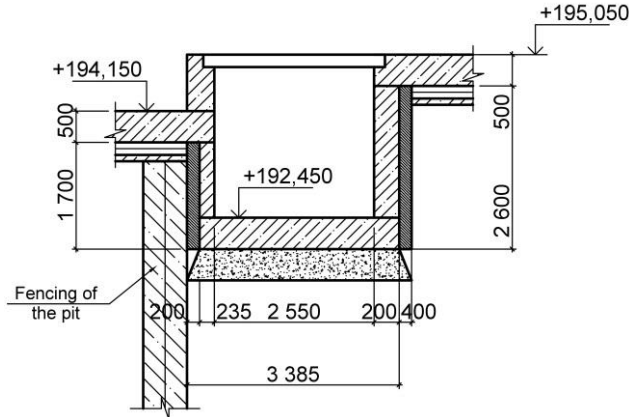

Fig. 2. Drainage plant drawing.



**Fig. 3.** Drainage plant.

It can be seen from the drawings that a pedestrian crossing is being constructed, under the floor base of which a drainage plant is being constructed. Works on the construction of a pedestrian crossing are carried out by an open method of work, i.e., a pit is dug in which work is carried out, then a ceiling is constructed and covered with soil. The estimate assumes that the construction of the drainage plant’s well will be carried out by the closed method of work (using the coefficient for the closed method), which is inappropriate. That is, it is assumed that open-pit construction of a pedestrian crossing will be carried out, then the foundation pit will be buried, and only after that, with an increase in the cost, work on the construction of the drainage plant will be carried out underground. Therefore, it was decided to add a coefficient of 0.8 - amendment: TSN-2001.3-29. O.P. Clause 8.1, name: When applying separate norms and prices of the closed method of work for the open method of work. Since there are no similar prices for the open method of work from other collections of TSN-2001. The scope of work at the stage of DD and WD may not coincide, because in fact, work can be done to a greater or lesser extent. The WD stage is done on the basis of the actual volume performed, and not on the basis of the data assumed at the DD stage. In this position, the volume was also changed from 71.5 m<sup>3</sup> to 32.6 m<sup>3</sup>. The final version of this estimate is shown in Table 5.

**Table 5.** Estimate issued with changes.

No.	Pricing code and resource codes	Name of works and costs	Un. Meas.	Number of units	Price per unit of meas., RUB	Correction factors	Winter appreciation coefficient	Total costs in the basic price level, RUB	Conversion coefficients (indices), norms of OH and EP	TOTAL costs in the current price level, RUB
1	2	3	4	5	6	7	8	9	10	11
<b>Section: Drainage plant</b>										
1	3.29-1006-2 Amendment: TSN-2001.3-29. O.P. clause 1.7.1	Drilling of mine shafts by a sinkhole in soils of group 3	100 m3 of soil according to the design outer outline	0.326						
		Volume: 0.715=(71.5)/100								

	W			5 934 .20	)*0.8	1.047	1 620 .38	24.82	40 217. 83
	MO			195.1 9		1.047	66.62	7.45	147.22
	incl. MW			2.78		1.047	0.95	24.82	23.57
	MR			8 199 .01		1	2 672 .88	4.42	12 134. 88
	OH from W	%	131				2 122 .70	122	49 065. 75
	EP from W	%	134				2 171 .31	51	20 511. 09
	OH and EP from MW	%	175				1.66	157	37.00
	LCW	man- hour	412.0 4			1.047	140.6 4		
							8 655 .55		122 11 3.77
	Surcharge for the operation of construction machines (from MW)			2.78	)*(0.8- 1)	1.047	- 0.19	24,82	- 4.71
	MO			2.78	)*(0.8- 1)	1.047	- 0.19	24,82	- 4.71
	incl. MW						- 0.33	157	- 7.39
	OH and EP from MW	%	175				- 0.52		- 12.10
	<b>Total with surcharge:</b>						<b>8 655.03</b>	<b>122 101.67</b>	

Also in this estimate, in the drainage plant section, other positions were corrected in terms of the scope of work and the use of a coefficient of 0.8.

The main purpose of checking the estimate documentation is not to overestimate or underestimate the cost estimate, but the main thing is the reliability of the data and the final passage of the State Expertise, where the estimate is sent after the audit in the Customer's company.

## 4 Conclusion

Thus, in this study, the significance of the audit of estimate documentation for the construction of transport infrastructure facilities is indicated, the sequence and features of its implementation are identified. In summary, the sequence of the audit based on the results of the study can be represented as follows:

- First stage. It is associated with the selection of data, the study of the entire set of estimate documentation for completeness, compliance and correctness. It is necessary to check the availability of a bill of quantities, its compliance with design decisions, the presence of basic stamps and signatures of responsible persons, and much more. At this stage, the expert gets acquainted with the project, studies the main technologies, features of the object.
- Main stage. At this stage, the expert conducts research work, expert assessment and analysis of the estimate documentation for compliance with regulations, the correctness of scope of works, the feasibility of technologies, the correct choice of material and labor resources. It is also important to check the correctness of the appreciation coefficients (in cases, for example, of closed construction, construction in the winter, dangerous conditions, etc.), indices and the correctness of the choice of the level of current prices for building materials.
- The final stage is the adoption of an expert decision. This can be both an individual and a group conclusion, which is drawn up in the form of a document (certificate, review, memo, etc.) and sent directly to the interested parties.

Thus, the audit of estimate documentation is an expert check, the purpose of which is to exclude the misuse of funds, confirm the correct application of prices and construction technologies.

## References

1. A.P. Korchagin, V.V. Soloviev, V.G. Miller, Vestnik of MIRBIS **1(29)**, 110-120 (2022) DOI: 10.25634/MIRBIS.2022.1.13.
2. V.V. Soloviev, A.P. Korchagin, Vestnik of MGSU **4**, 605-616 (2020) DOI: 10.22227/1997-0935.2020.4.605-616
3. A. Bobkov, B. Orlov, N. Belozerova, I. Provotorov, I. Kozlova, MATEC Web of Conferences **170**, 01093 (2018) <https://doi.org/10.1051/mateconf/201817001093>
4. N. Yaskova, T. Kolosova, IOP Conference Series: Materials Science and Engineering **869(6)**, 062050 (2020) DOI:10.1088/1757-899X/869/6/062050
5. O. Kutsygina, S.S. Uvarova, S.V. Belyaeva, A.V. Chugunov, Advances in Intelligent Systems and Computing **983**, 2 (2019) DOI: 10.1007/978-3-030-19868-8\_4
6. O.V. Didkovskaya, O.A. Mamayeva, M.V. Ilyina, Procedure Engineering **153**, 131 – 135 (2016) DOI: 10.1016/j.proeng.2016.08.092
7. M.P. Bovsunovskaya, E3S Web of Conferences **263**, 05048 (2021) <https://doi.org/10.1051/e3sconf/202126305048>
8. S.N. Shipova, Economy and entrepreneurship **12(137)**, 1324-1327 (2021) DOI: 10.34925/EIP.2021.137.12.263
9. I. Karakozova, Y. Prochorova, MATEC Web of Conferences **193**, 05002 (2018) <https://doi.org/10.1051/mateconf/201819305002>
10. M.P. Bovsunovskaya, Procedure Engineering **165**, 960 – 964 (2016) <https://doi.org/10.1016/j.proeng.2016.11.806>
11. I. Karakozova, Y. Prochorova, International economy **9**, 668-684 (2022) DOI: 10.33920/vne-04-2209-05