

Two-axle bogie vibration damping system with additional damping elements

*Anna Avdeeva**, *Galina Khromova*, and *Davran Radjibaev*

Tashkent State Transport University, Tashkent, Uzbekistan

Abstract. There are no optimal vibration damping designs for safe movement at the present stage of the development of high-speed rail transport. The purpose of improving existing structures is their ability to simultaneously dampen both longitudinal and transverse vibrations. For dynamic research, an analytical method has been developed for calculating the stresses and deformations of the sidewall of the frame of an electric locomotive bogie in motion, taking into account the unevenness of the joints. The result of the work on creating a new design of a two-axle bogie of a railway vehicle, with additional damping elements of the vibration damping system, is the Patent of the Republic of Uzbekistan for the invention No. IAP 06498 [1]. The considered design is universal and suitable for a subway car, motor locomotive, or railcar.

1 Introduction

Due to the significantly increased speeds of railway rail transport, increased requirements are imposed on bogies. The bogie is the main carrier unit of electric rolling stock (locomotive, railcar, electric train, subway train). The body weight, traction, and braking forces developed by each wheel pair are transferred to it. When the bogie moves along a straight or curved section of the track, it perceives the forces are acting from the wheelsets when they interact with the rails in the vertical and horizontal planes.

A motor bogie of a high-speed railway vehicle is known according to the patent of the Russian Federation for the invention RU No. 2441785, containing an axle, a single-stage axial gearbox, two wheels pressed onto the axle, each of which has two brake discs, and two axle boxes on the disk part. A gear train with arc teeth is provided to connect the axial gearbox with the traction motor. The frame is formed by longitudinal beams bent by the middle part downwards and one transverse beam connecting the middle parts of the longitudinal beams to each other. On the longitudinal beams, fastening elements for motor wheelsets are provided. On the transverse beam, there are fastening elements for two traction motors and disc brake equipment for each wheel [2].

The disadvantage of this design of the motor bogie of a railway vehicle is the complexity of the proposed design, a large mass due to the presence of gearboxes and two traction motors, damping only vertical loads. The proposed frame design has a two-stage spring suspension, while the second stage of the spring suspension can be made pneumatic, which

* Corresponding author: nyusik22@mail.ru

is a very complex structure and, due to a large number of system parts, does not provide the necessary reliability and durability.

It is also known two-axle bogie subway car according to the patent of the Russian Federation for the invention RU No. 2508934, containing wheelsets connected through axlebox suspension with the frame of the bogie; bogie frame, on which brake equipment, electric motors, kinematically coupled clutches and gearboxes with wheel sets are installed. The bogie frame is made closed and consists of two longitudinal and three transverse beams (central and two end transverse beams). The axis of rotation of the electric motor is below the axis of rotation of the wheelsets. The reaction moment from the electric motor is transmitted through the brackets and reaction rods to the transverse beams to evenly distribute the load on the bogie frame, while the transverse beams are made bent down. The cart contains a system of hydraulic vibration dampers for connection with the frame and car body [3].

The disadvantages of this design of the subway car bogie are that it has low durability and reliability due to a large number of parts, low maintainability, large mass due to the presence of traction motors, gearboxes, and couplings, low vibration damping efficiency, which is especially important at high speeds of movement of railway rolling stock. Simultaneous damping of vertical, longitudinal, and torsional vibrations and loads is impossible.

The closest in technical essence is a non-motor bogie of a high-speed railway vehicle according to the patent of the Russian Federation for the invention RU No. contains an axle, two wheels pressed onto the axle, as well as the main brake disc and two additional brake discs mounted on the axle, placed on both sides of the main brake disc at equal distances from it, while the spring suspension of the bogie is made in two stages [4].

The disadvantage of this design of a non-motorized bogie of a high-speed railway vehicle is that it has low durability and reliability due to a large number of parts; it also has low damping efficiency, which is especially important at high speeds of railway rolling stock. Simultaneous damping of vertical, longitudinal, and torsional vibrations and loads is impossible.

The purpose of the design improvement is to increase the reliability and durability and improve the driving performance of the railway vehicle bogie by increasing the damping capacity of the vibration damping system as a whole, especially in curves, with the provision of horizontal and vertical damping of vibrations and shock loads, which is especially important at higher speeds; increases the smoothness of the vehicle and ensures the safety of train traffic.

The high-speed rolling stock running gear modernization, setting itself the task of reducing vibrations and increasing the smoothness of operation, involves multilateral dynamic studies of the main characteristics of the structure, such as natural frequencies, natural shapes, and damping coefficients of vibrations. This research stage is usually quite complex, as it includes numerous systems of differential equations, the results of which must correspond to statistical studies for various sections of the railway track. The basis for choosing the method for dynamic calculations was the mathematical models of vibration dampers and shock absorbers for rail vehicles [6] and some computational studies in this direction [9 - 15].

2 Methods

The research methodology includes the compilation of mathematical models for optimizing the spring suspension system of the high-speed electric train with improved elastic-dissipative properties of the suspension and the substantiation of dynamic strength parameters. For research, standard materials resistance methods, the theory of elasticity, the

theory of vibrations, and the dynamics and strength of machines applying computers were used. Numerical studies were carried out in the programming environment Mathcad 15.

In this sphere, research has been carried out. It is being carried out by leading scientists around the world, such as S.A. Brebbia (Wessex Institute of Technology, UK), G.M. Carlomagno (University of Naples di Napoli, Italy), A. Varvani-Farahani (Ryerson University, Canada), S.K. Chakrabarti (USA), S. Hernandez (University of La Coruna, Spain), S.-H. Nishida (Saga University, Japan), authoritative scientific schools, and prominent scientists of MIIT, PSURW, MAI, VNIIZhT, JSC VNIKTI, JSC Russian Railways, etc. They worked on the issues raised in the CIS countries. A significant contribution to solving many complex problems and checking theoretical conclusions related to the study of the processes of oscillations of the spring suspension of the rolling stock was made by the Russian Research Institute of Railway Transport (CNII MPS) and the Russian Research Institute of Car Building (NIIV), which, along with theoretical studies, conducted a large number of experimental studies, both stand, and field ones.

3 Results and Discussion

The project is based on the two-axle bogie with spring suspension, on which additional brake structures are placed. Two non-motorized wheelsets are mounted on the frame, each containing two pressed-on wheels. The spring suspension of the bogie is made in two stages, with hydraulic vibration dampers in the central suspension mounted obliquely. Cylinder springs are used in the box and central suspensions.

The difference between the design proposed in the article is that the bogie is equipped with additional devices for damping vibrations in the systems of longitudinal and transverse links of the bogie with the vehicle body.

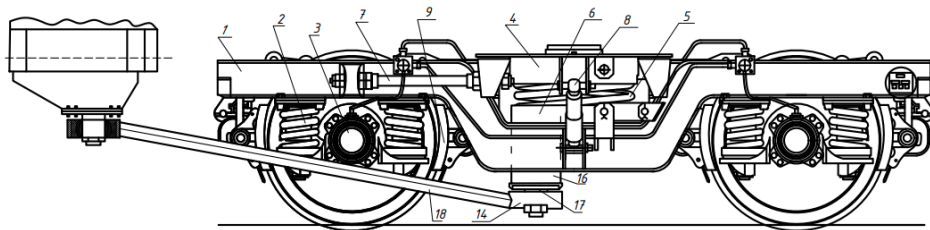

Fig. 1. The general scheme of the proposed bogie with the device for its longitudinal connection with the body of the railway vehicle, side view: 1 is frame; 2 is box spring suspension; 3 is wheelsets with axle boxes; 4 is above the spring bar; 5 is central suspension, consisting of double-row springs; 6 is frame pallets; 7 is leashes; 8 is hydraulic vibration dampers; 9 is brake linkage; 14 is cylindrical elastic-damping shock absorber; 15 is metal sleeve; 16 is bracket; 17 is coupling cylindrical rod; 18 is metal rod.

The device for longitudinal connection of the truck with the body of the railway vehicle (Fig.1, 2) contains a bracket 11 fixed on the main frame of the body of the railway vehicle 10 with a tie cylinder rod 12. It is dressed with a rubber-metal cylindrical sleeve 13 with a corresponding inner surface of the tie rod 12. It is dressed with a cylindrical elastic-damping shock absorber 14 (Fig.2. Section A), preloaded with an interference fit by an outer metal sleeve 15. On the longitudinal beam of the bogie frame 1, a bracket 16 with a coupling cylindrical rod 17 is threaded, which is also dressed with a cylindrical elastic-damping shock absorber 14 (Fig. .2 Section A), to which the inclined metal rod 18 is attached. The other end of the inclined metal rod 18 is pressed onto the outer metal sleeve

15. In this case, the inclined metal rod 18 is fixed on the bracket 11 of the frame of the body of the railway vehicle 10 using a threaded connection 19. Cylindrical elastic-damping shock absorber 14 (Fig.2. Section A) consists of tightened metal and rubber elements with an outer metal sleeve 15. A rubber-metal cylindrical sleeve 13 is put on the tie rod 12, consisting of a rubber cylindrical ring 20, a shaped metal cylindrical washer with "C"-shaped section 21, on the outer surface of which there is a figured sealing rubber cylindrical element 22, pressed with an interference fit by an outer metal sleeve 15 (Fig. 2 Section A).

Moreover, the number of figured metal cylindrical washers with a "C"-shaped section 21 and cylindrical rubber rings 20 in our design of the cylindrical elastic-damping shock absorber 14 can vary from two to six, depending on the mass of the railway vehicle. The greater the mass, the more it is necessary to install elastic damping elements 20 and 21 in the shock absorber 14.

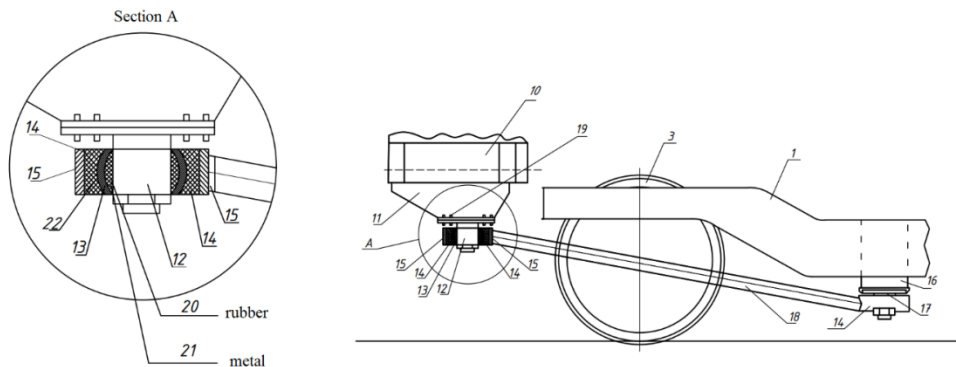

Fig. 2. Scheme of installation of the device for longitudinal connection of the bogie with the railway vehicle body. Section A – design cylindrical elastic-damping shock absorber for a longitudinal connection device bogies with the body of the railway vehicle: 10 is body of the railway vehicle; 11 is bracket; 14 is cylindrical elastic-damping shock absorber; 15 is metal sleeve; 16 is bracket; 17 is coupling cylindrical rod; 18 is metal rod; 19 is threaded connection; 20 is rubber cylindrical ring; 21 is washer with "C" - shaped section; 22 is seal.

An additional device for damping vibrations in the systems of cross-links of the bogie with the vehicle body (figure.3.b) contains a bolster 4, based on spring-loaded friction wedges 23, located between the bolster 4 and the vertical posts of the central spring opening 25 of the longitudinal side beams 24 bogie frames. The friction wedge 23 has an inclined curved surface for interaction with the inclined curved plane of the bolster 4 (figure.3.a)), in which special recesses are made in the contact zone with the wedge. The bolster 4 (figure.3.a)) rests with its supporting surfaces through the spring sets on the side longitudinal beams 24 of the bogie frame in the central spring opening 25 (figure. 3 a)). Special liners are welded to the inclined surface of special recesses, with a curved working surface made of wear-resistant material that contacts with the wedge, which has guaranteed larger general radii than those that form the radii of the wedge working surface. At the same time, the bolster is mounted by supporting surfaces on spring sets, including double-row springs of increased flexibility, two of which are installed under friction wedges, having inclined curved surfaces for interacting with inclined curved surfaces of the liners above the spring bar, interacting using strips of wear-resistant material with the corresponding surfaces in the central openings of the side longitudinal beams of the bogie frame, supported by axle box openings through V-shaped multilayer elastic elements 29 axle box suspension and adapters interacting with them on the bearing units of the wheel pairs, braked using brake shoes mounted on the shoes. V-shaped multilayer elastic elements of

axle box spring suspension are made of steel layers and gaskets in the form of rubber layers. According to the calculations, when the vehicle mass fluctuates from 22 to 168 tons, there should be from six to twelve layers on each side of the wheelset axle.

On the straight sections of the track, the damping of the transverse vibrations of the bogie will be made by the standard device, more precisely, due to the damping of the central suspension, consisting of double-row springs of increased flexibility, axle box springs, and the operation of the hydraulic vibration damper. When driving in curves, an additional device for damping vibrations in the cross-link systems of the bogie with the vehicle body will be included in the work proposed in the article (figure.2 b)). When passing curved sections of the track (figure.3. b)), when the wheel of the first wheel pair in the direction of travel interacts with the head of the outer rail with its crest, additional centrifugal forces F_p and moments M_p arise, which tend to displace the elements of the bogie frame in a horizontal plane, relative to normal position (movement in straight lines – figure. 3 a)).

Due to the curvilinear general of the mating surfaces of the bolster 4 and the wedge of special inserts 28, made of wear-resistant material, and the fact that the curvature of the mating surface of the bolster 4 is greater than the curvature of the mating surface of the wedge (figure.4.b)), in the event of angular movements of the bolster 4 and the side longitudinal beam 24 of the bogie frame 1 in the horizontal plane, their point of contact is displaced along the generatrix of the contact surface of the wedge relative to the longitudinal axis 30. The resulting forces F_n , directed towards the center of the radius forming the surface, onto the friction surface "wedge - longitudinal side beams of the bogie frame" are decomposed into a force F normal to the surface, and a friction force F_t is acting in the plane of friction. Thus, the equilibrium position of the wedge in the system "bolster beam - wedge - longitudinal side beams of the bogie frame" is achieved, and a moment arises that resists the mutual displacement of the longitudinal side beams of the bogie frame M_p (figure.3.b)).

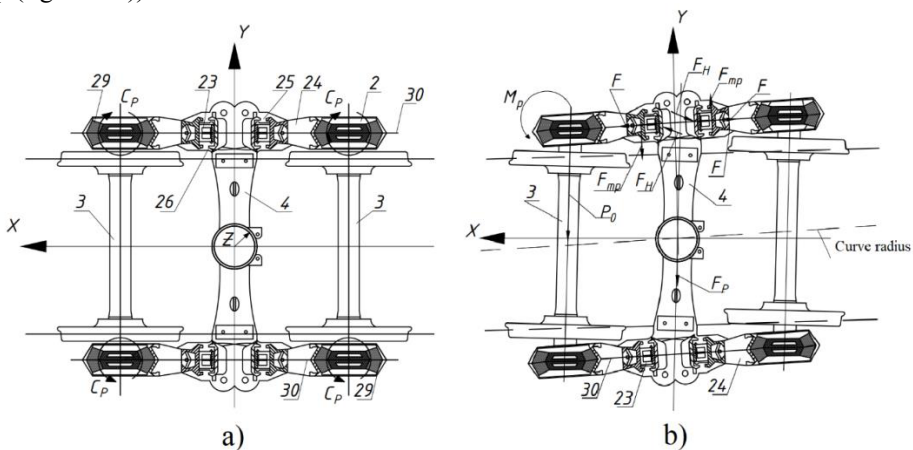

Fig. 3. Kinematic power scheme of additional device operation of cross-links of the bogie with the vehicle body: a) on straight sections of the railway; b) when it moves in curves. 3 is wheelset; 4 is bolster; 23 is spring-loaded friction wedges; longitudinal side beams; 25 is vertical rods of the central spring opening; 26 is recesses; 27 is bearing surfaces; 28 is liners made of wear-resistant material; 29 is multilayer elastic elements of axle box spring suspension; 30 is longitudinal axis of the side beams.

In its turn, thanks to the additional V-shaped multilayer elastic elements 29 (figure. 3 a)) of axle box spring suspension and located at an angle to the longitudinal axis of the side longitudinal beam of the bogie frame 30, having a given torsion rigidity relative to the

vertical axis Z (Average), there is an elastic dissipative resistance to misalignment of the wheel sets 3, and the longitudinal side beams 24 of the bogie frame, caused by the actions of forces and moments.

The proposed additional elastic-dissipative connection of the axle box spring suspension of the longitudinal side beam 24 of the bogie frame 1, with a wheel pair 3, as well as a dissipative connection with the bolster 4 using the central suspension consisting of double-row springs 5 of increased flexibility, will increase the "connectivity" of the elements of the bogie frame 1 and reduce the frame misalignment and "running" of the side longitudinal beams 24 of the bogie 1. In the central spring suspension, dynamic vibrations will also be damped by hydraulic vibration dampers 8 installed obliquely between the frame of the bogie 1 and the main frame of the body 10 of the railway vehicle, which serve to damp the vertical and horizontal vibrations of its body. This two-stage design of spring suspension (box and central) of the railway vehicle reduces its dynamic impact on the track, thereby reducing the wear of wheels and rails and, at the same time, reducing the resistance to movement of vehicles (subway cars, passenger cars, motor locomotives, railcars) and the likelihood of their derailment, rails (stability). This increases the reliability and durability of vehicles as a whole and also improves the driving performance of the bogie, especially in curves, increases the smoothness of the ride, and ensures the safety of train traffic.

The proposed bogie will find wide application in railway transport, as it is interchangeable with typical bogies of passenger cars and subway cars currently used on railway vehicles. For example, two-axle bogie models 68-921, 68-922, designed for operation as part of passenger and mail-luggage trains on the railway lines of the CIS countries and the Baltic states with a gauge of 1520 mm, allowing circulation of the rolling stock of gauge 1-T State All-Union Standard 9238. These bogies of models 68- 921 and 68-922 have been manufactured since 2013 by JSC Tashkent Plant for the Construction and Repair of Passenger Cars.

As a result of installing additional damping elements in devices for damping vibrations in the systems of longitudinal and transverse connections of the bogie with the vehicle body, the effect of increasing the damping capacity of the bogie and the entire vehicle as a whole will be achieved. Thus, the reliability and durability of vehicles are increased. Regarding its useful qualities, the proposed two-axle bogie of the railway vehicle will find wide application in railway transport and can compete with foreign inventions of this type.

The second objective of this article is to develop the dynamic calculation method of the stress-strain state of the sidewall of the bogie frame of an electric locomotive under loading that occurs when it moves along the track with periodic joint roughness.

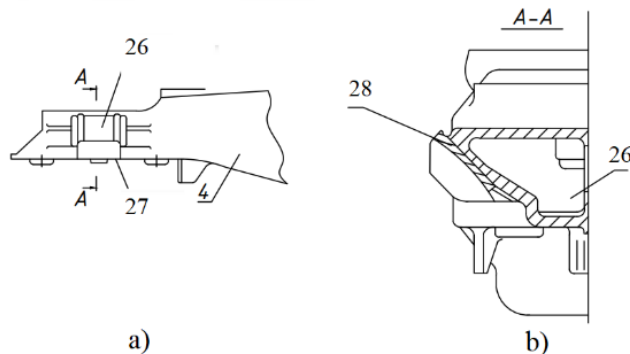

Fig. 4. Drawing of a bolster with wedge with special recesses made in the contact zone: a) side view; b) cross-section A-A. 26 is special recesses; 27 is supporting surface; 28 is welded liners.

The frame of the locomotive bogie is a complex spatial structure that perceives in operation both static and dynamic loads acting on the units of the bogies and the body. The greatest efforts are applied to the middle part of the longitudinal beams, so the sidewall of the bogie frame has a larger section in the middle and a smaller one at the edges. In this regard, we propose an analytic-numerical method for calculating the dynamic strength of the supporting frame of the locomotive bogie frame, assuming the variability of its mass and bending stiffness along the length under the action of a harmonic load [8].

The equivalent load-bearing frame of the sidewall of the bogie frame of an electric locomotive is modeled by an elastic rod of the variable cross-section with a variable mass and bending stiffness. The difference between the proposed model and the existing ones is that it considers the variability of the section, mass, and bending stiffness along the length of the equivalent beam, which corresponds to real operating conditions. For a specific numerical calculation, the bogie frame of a high-speed electric train operated in Uzbekistan was taken.

For the model we propose, the parameters of the equivalent supporting frame of the sidewall of the bogie frame of a high-speed electric train are taken in the form of variable functions (polynomials of n - degree):

- linear mass of the sidewall of the frame of the electric locomotive bogie (kg/m) is in this case, the length of the sidewall of the frame of the electric locomotive bogie is 4658 mm, and the X coordinate varies from 0 to 4.658 m;

$$m_T(X) = m_o (a_o + a_1 X + a_2 X^2 + \dots + a_n X^n), \quad (1)$$

- the presented moment of inertia of the sections of the sidewall of the bogie frame along the axis X - $I_X (cm^4)$ is:

$$I_X(X) = I_o (b_o + b_1 X + b_2 X^2 + \dots + b_n X^n), \quad (2)$$

- presented bending stiffness is

$$J_I(X) = E I_o (b_o + b_1 X + b_2 X^2 + \dots + b_n X^n). \quad (3)$$

The optimal value of n (the degree of polynomials) is selected using a computer by piecewise linear approximation based on the actual dimensions of the sidewalls of the frames of electric locomotive bogies. For the high-speed electric train, we took the value $n = 8$ in the numerical calculation (in this case, the error was $\delta = 0.001$).

To analyze the stress-strain state of the equivalent frame of the sidewall of the frame of the electric locomotive bogie, we use the differential equations of bending vibrations of straight bars of variable cross-section [7, 8] (assuming the longitudinal and torsion vibrations are small compared to the other components)

$$m_T(X) \frac{\partial^2 W(X,t)}{\partial t^2} + E I_X(X) \frac{\partial^4 W(X,t)}{\partial X^4} + E \frac{\partial^2 I_X(X)}{\partial X^2} \cdot \frac{\partial^2 W(X,t)}{\partial X^2} = (X \eta_H, t) + P_D(X, t), \quad (4)$$

where $W(X, t)$ are bending vibrations of the sections of the sidewall of the bogie frame; $P_D(X, t)$ is a dynamic force arising in the vertical direction under the action of various necessary equipment installed on the bogie frame and the frame of the electric locomotive body, for example, from vibrations of the electric traction motor. Moreover, depending on the scheme of its location (the specific brand of the electric locomotive), the spectrum of this load along the length X is different; $\eta_H(X, t)$ is function of the track roughness change, we assume in the form

$$\eta_H(X, t) = \left(2C \frac{\eta_0}{2} (1 - \cos \omega t) + 2\beta \eta_H \right) \eta_H(X) \quad (5)$$

where $\eta_H(X) = \sin \frac{\pi X}{L_H}$; ω is frequency of change of irregularity in time; thus,

$$\eta_H(X, t) = \sin \frac{\pi X}{L_H} (C \cdot \eta_0 (1 - \cos \omega t) + \eta_0 \beta \omega \sin \omega t). \quad (6)$$

Next, we perform solutions on a computer by the method of piecewise linear approximation and the method of iterations. We divide the entire beam (the sidewall of the frame of the electric locomotive bogie) into 20 points, provided that the X coordinate varies from zero to 4.658 m; for each of these sections, we introduce the coefficients RiK, which are CONST (constant values), where $k = 1, 2 \dots 20, n = 8$

$$R_{1K} = 2 \cdot E \cdot I_0 \cdot (b_2 + 3b_3 + \dots + 28b_8 \cdot X^6); \quad (7)$$

$$R_{2K} = I_0 \cdot (b_0 + b_1 X + b_2 X^2 + \dots + b_8 X^8)$$

$$R_{3K} = m_T(X) = m_0(a_0 + a_1 X + a_2 X^2 + \dots + a_8 X^8).$$

As a result, for each k-section, we obtain equations of the form (4) with fixed (constant) coefficients:

$$R_{1K} \cdot \frac{\partial^2 W(X, t)}{\partial X^2} + R_{2K} \cdot \frac{\partial^4 W(X, t)}{\partial X^4} + R_{3K} \cdot \frac{\partial^2 W(X, t)}{\partial t^2} = \eta_H(X, t) + P_{DK}(X, t) \quad (8)$$

The solution of the differential equation (8) is performed similarly to the methods of works [16-24], using the classical Gauss method, with the separation of variables by the Fourier method [18]:

$$W_K(X, t) = W_K(X) T_K(t) \quad (9)$$

where $W_K(X)$ are own functions; bending (transverse) oscillations of the system are obtained in the form:

$$W_K(X) = A_k \operatorname{sh} \omega_k X + B_k \operatorname{ch} \omega_k X + C_k \sin \omega_k X + D_k \cos \omega_k X \quad (10)$$

Further, the Laplace transforms linear differential equations into algebraic ones in time. For integral calculations, the Simpson formula and the piecewise linear approximation method were used. All numerical research methods are implemented in the *Mathcad 14* programming environment. Having determined each of the 8 sections, and their dynamic components, we determine the maximum stresses depending on the curvature of the section (see Table 1). Calculations were made at design speed $V = 160$ km/h, with maximum bogie mass $m_f = 7450$ kg., and minimum design mass $m_t = 24 \cdot 10^3$ kg., (maximum load from wheelset on rail 176.58 kN); for cast frame, the pivot beam of which is made of steel 20 L with allowable stress of 140 MPa, the rest of the bogie frame Steel 3sp. with allowable stress of 150 MPa. All received values are less than acceptable. Let's consider a few more controllable indicators of structural reliability (see Table 2.), including the stresses values in the springs (see Table 3). It can be seen from the tables that all calculation results correspond to State All-Union Standard R 58720-2019.

Table 1. Dependence of the maximum stresses depending on the curvature σ_{\max} , MPa (according to the Patent of the Republic of Uzbekistan for the invention No. IAP 04469 [1])

№ of sector	Curve radius Rcr i, m							
	250	500	750	1000	1250	1500	1750	0
1	56.212	45.344	39.74	16.71	9.318	7.361	6.214	5.426
2	109.721	91.677	85.16	70.18	63.451	49.168	35.162	27.037
3	71.455	67.789	52.6	43.46	31.638	30.033	35.679	13.451
4	138.36	123.734	61.85	58.76	52.893	50.135	36.678	5.984
5	125.018	107.895	89.34	70.68	62.232	41.797	35.521	21.467
6	68.769	62.89	57.93	49.06	35.161	27.033	14.564	10.988
7	93.584	87.892	80.86	72.68	60.072	38.791	34.532	21.469
8	41.671	40.011	29.78	25.634	16.212	10.621	7.016	4.961

Table 2. Controlled indicators of safe operation of a two-axle bogie (according to the Patent of the Republic of Uzbekistan for the invention No. IAP 04469 [1])

Controlled indicators	State All-Union Standard R 58720-2019	Estimated values
The difference between the total static deflections of the spring suspension of the bogie in cars with the maximum and minimum design mass	no more than 55 mm	50.09 mm
Static deflection of the spring suspension of the bogie under load, with a minimum design mass	not less than 8 mm	10.9 mm
Coefficient of structural reserve of deflection of the spring suspension, with a static deflection of more than 50 mm	not less than 1.75 mm	1.89
coefficient of relative friction when using friction dampers in the spring suspension of the bogie (under maximum load)	not less than 0.07 mm	0.07÷0.089

Table 3. Results of verification calculations of allowable stresses of spring springs τ_{\max} , MPa (according to the Patent of the Republic of Uzbekistan for the invention No. IAP 04469 [1])

Calculation modes	Permissible stresses	Outer high spring	Internal high spring	Internal low spring
First mode	1000	767.587	780.033	691.368
Second mode	800	648.033	690.448	543.987

4 Conclusion

1. The article's authors developed an algorithm for the dynamic calculation of the stress-strain state of the sidewall of the frame of the electric locomotive bogie, taking into account the periodic load changes from the joints of the railway track. The proposed analytical method is based on classical numerical calculation methods: iteration and piecewise linear approximation. This calculation scheme can be used to predict the operation of existing electric locomotives and to design new ones.

2. The calculations for the strength of the bogie frame of an improved design meet the requirements of State All-Union Standard R 58720-2019, valid on the territory of Uzbekistan. Tables 1, 2, 3 show that all indicators are within the permissible values.

3. The article's main idea is an improved design of the two-axle bogie of a railway vehicle. Additional elements of the vibration damping system increase reliability and durability of the rolling stock and can improve driving performance, especially in curves, by increasing the damping capacity of the vibration and shock dampening system. The design is protected by the Patent of the Republic of Uzbekistan for the invention No. IAP 04469 [1].

4. In terms of its useful qualities and efficiency, the proposed two-axle bogie of a railway vehicle will be widely used in the construction of subway cars, passenger cars, motor locomotives, and railcars. It can compete with foreign inventions of this type.

References

1. Khromova G.A., Khromov S.A., Mukhamedova Z.G., Safarov B.Sh. Trolley biaxial railway vehicle. Patent of the Republic of Uzbekistan No. IAP 06498. Publ. 06/30/2021, Bull. No. 6.
2. Gapanovich V. A., Yagovkin A. N., Grek V. I., Fuchs G., Rosegger E., Trantin H., Khas H. High-speed railway vehicle motor bogie. Patent of the Russian Federation RU No. 2441785. Published on February 10, 2012, Bull. No. 4
3. Andreev A. A., Kolesin A. Yu., Gomzin A. A., Kryuchkov V. N. Two-axle bogie of a subway car. Patent of the Russian Federation RU No. 2508934. Publ. 03/10/2014, Bull. No. 7.
4. Shilkin V.P., Devyatov A.V., Kalinin O.V., Fuchs G. Non-motorized high-speed transport trolley. RU130566U1. (2013)
5. Pismenny E.A., Gabets A.V., Markov A.M., Gabets D.A. Development and strength calculation of a new structure of the friction wedge assembly of damping the oscillations of a freight car trolley, **5** (65) (2020)
6. Orlova A. M., Rudakova E. A., Gusev A. V. Improving the spring suspension of freight cars, taking into account the need to reduce the impact on the track. Bulletin of the Petersburg University of Railway Communications. No. 1. (2018)
7. Orlova A. M., Rudakova E. A. and Gusev A. V. Reasoning for assignment of permissible minimum value coefficient of constructive spring suspension deflection reserve of freight cars bogies. Proceedings of Saint Petersburg transport University, **14**(1), pp. 73–87 (2017)
8. Goncharov S.E., Pogorelov D.Y., Simonov V.A. Comparative assessment of the impact on the track and resistance to movement of innovative cars and cars of obsolete designs using computer modeling methods. Transport engineering. No. 1 (74). (2019)
9. Gabets A.V., Markov A.M., Gabets D.A, Komarov P, Chertovskikh E.O. Investigation of chemical composition and material structure influence on mechanical properties of special cast iron. METAL 2017 - 26th International Conference on Metallurgy and Materials, Conference Proceedings. pp. 782-788 (2017)
10. Boronenko Yu.P. Cars with increased load from wheels on rails – increase reserve of carrying and delivery capacity of railways. Transport of the Russian Federation, **5**(18), pp. 52–55. (2008)
11. Sokolov M.M. Varava V.I., Levit G.M. Vibration dampers of the rolling stock: a Handbook. M.: Transport. pp. 216 (1985)
12. Manashkin L.A., Myamlin S.V., Prikhodko V.I. Vibration dampers and shock absorbers for rail vehicles (mathematical models). Artpress, p. 196 2007.
13. I.S. Biryukova, A.N. Savoskina. The mechanical part of the rolling stock. M.: Transport, p.440 (1992)
14. Mendel V.B. Railway Rolling Stock of Electrical Railways, Moscow, Transport. pp.232 (1974)

15. Kamaev V.A. Optimization of Parameters of Running Parts of Railway Rolling Stock. Moscow. Mechanical Engineering. (1980)
16. Belforte P., Cheli F., Diana G., and Melzi S. Numerical and experimental approach for the evaluation of severe longitudinal dynamics of heavy freight trains. *Vehicle System Dynamics*, **46**(S1), 937-955 (2008)
17. Tianwei Q., Weihua M., Dong W., and Shihui L. Influence of coupler and buffer on dynamics performance of heavy haul locomotive. *The Open Mechanical Engineering Journal*, **9**(1). (2015)
18. Powell, J. P., and Palacín, R. Passenger stability within moving railway vehicles: limits on maximum longitudinal acceleration. *Urban Rail Transit*, **1**(2), 95-103. (2015).
19. Sebeşan I., Crăciun C., and Mitu, A.M. The use of ringfeder characteristics for evaluation of longitudinal dynamic forces in train. *Scientific Bulletin of Politehnica University of Bucharest*, **76**, 76-88 (2014)
20. Fayzibaev, Sh. S., Avdeeva, A.N., Mamaev Sh. I. Evaluation of the wear of the tire wheel pair at rolling friction// *Academicia: An International Multidisciplinary Research Journal*, **10**(6), pp. 1602-1606 (2020), doi: 10.5958/2249-7137.2020.00782.X
21. Yu.V. Demin, L.A. Dlugach V.V., Korotenko O.M. Markov. Self-oscillations and movements of rail vehicles. Kyiv: Naukova Dumka, p. 157 (1984)
22. Fayzibaev Sh. S., Khromova G. A. and Mahadalieva M. A. A dynamic model for studying the volumetric dimensions of the main frame of an electric locomotive, taking into account the installation of a damping draft gear in an automatic coupler" *Izv. Transsib I*, **49** (2015)
23. Khromova G. A., Khromov S. A., and Radzhibaev D. O. Mathematical model of vibrations of a locomotive bogie frame structure of complex configuration at increased motion speed in transport engineering. *Rail transport: Current challenges and innovations*, **1**(1), 14-27. (2019).
24. Timoshenko S.P., Young, D.H., Weaver W. Trans. from Eng. by L.G. Korneychuk, Ed. by E.I. Grigolyuk. *Oscillations in engineering*. M.: Mashinostroenie, p. 472 (1985)