

Study on Selective Insulation On-line Monitoring Technology for Mine Power Network

Zhong-kui Lia^{1,2,3,a*}, Le-jun Wang^{1,2,3,b}

¹China Coal Research Institute, Beijing 100013, China; ² Engineering Research Center of Coal Mines Emergency Technology Equipment, Beijing 100013, China; ³ Beijing Mine Safety Engineering Technology Research Center, Beijing 100013, China

Abstract—In this paper, by studying the change rule of zero sequence voltage when single-phase leakage occurs, the detection method of insulation decline of mine cables is studied, especially the additional low-frequency signal sampling technology of power cables. Combined with the conventional leakage protection technology, the online monitoring equipment and supporting software for the insulation parameters of power cables are developed to realize the online monitoring of the insulation of each branch cable of the mine low-voltage power supply system and achieve the purpose of selective leakage protection.

1. Introduction

Leakage fault is a leakage phenomenon that the insulation of live conductor to ground drops to a certain extent and the leakage current increases to a certain extent. The leakage fault will make the three-phase voltage of the power grid asymmetric to the ground, and the neutral point will also produce displacement, and generate zero sequence voltage and zero sequence current. The leakage current of underground power grid is divided into decentralized leakage and centralized leakage. Decentralized leakage is caused by the insulation level of the whole power supply line dropping to a certain extent. Centralized leakage is caused by the failure of one phase to ground insulation of the three-phase power grid. This leakage current is very large, and it is also very harmful to people[1].

The main reasons for the leakage fault of the mine power supply system are the leakage caused by inadequate inspection and improper operation, the cable insulation layer is damaged, the cable insulation is aging, the cable is affected with moisture, the electrical equipment or cable is improperly selected for overload operation, the cable or switchgear is operated under overvoltage, the overall insulation level of the grid is reduced due to too long cable or too many switches, the connector is not secure, and the horn mouth is not tightly blocked, etc. The leakage fault needs power failure maintenance, which has a serious impact on production. If the maintenance is not timely, electric shock accidents are also very likely to occur. If the ventilator is shut down, it may cause gas accumulation and gas security accidents[2].

At present, the application of switch leakage protection device used in coal mine is not very reliable, and occasionally misoperation occurs. Because of the capacitive current compensation device, the power grid protection device can not correctly select the fault line,

and make the non fault line trip, which affects the safety of coal mine power supply and coal mine production. The insulation online detection system designed in this paper can not only monitor the insulation status of the whole power grid, but also accurately judge the fault line to avoid the occurrence of misoperation. It can replace the preventive maintenance, greatly improving the safety of the coal mine power grid, which is of great significance[3].

2. Change rule of zero sequence voltage under single-phase leakage

It is more reasonable and convenient to use the node voltage method to analyze the node network formed by the relative ground insulation of the mine power grid and the power grid. As shown in the single-phase leakage diagram in Figure 1, when phase A of the circuit in the figure leaks, its equivalent circuit is shown in Figure 2. Assume that R is the leakage resistance, which is connected in parallel to Z_0 , destroying the symmetry of the power grid and generating zero sequence voltage U_0 [4].

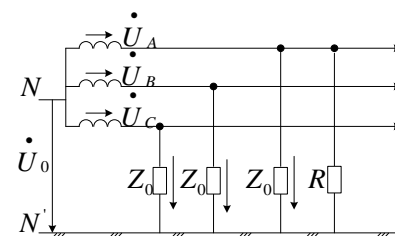

Figure 1. Single phase leakage diagram.

^{a*} Corresponding author: lizhongkui@ccrisc.cn

^bwanglejun@ccrisc.cn

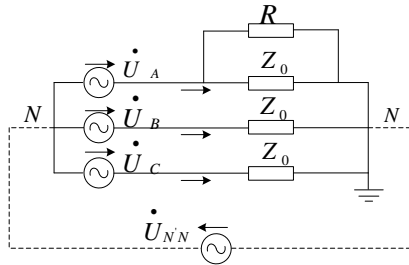

Figure 2. Single phase leakage equivalent circuit diagram.

For three-phase symmetrical voltage \dot{U}_A , \dot{U}_B , \dot{U}_C , the following formula is satisfied:

$$\dot{U}_A + \dot{U}_B + a^2 \dot{U}_C = \dot{U}_A + a \dot{U}_A = 0 \quad (1)$$

Wherein: a , a^2 is phasor operator.

$$a = e^{j120^\circ} = -(1/2) + j\sqrt{3}/2 \quad (2)$$

$$a^2 = e^{-j120^\circ} = -(1/2) - j\sqrt{3}/2 \quad (3)$$

Zero sequence voltage (displacement voltage) can be obtained according to formula (1):

$$\text{Set } Z_0 = R // Z_0$$

$$\begin{aligned} \dot{U}_0 &= \dot{U}_{NN'} = -\dot{U}_{NN'} \\ &= -(\dot{U}_A / Z_0 + a^2 \dot{U}_A / Z_0 + a \dot{U}_A / Z_0) / (1 / Z_0 + 1 / Z_0 + 1 / Z_0) \end{aligned} \quad (4)$$

After sorting out, we can get:

$$\dot{U}_0 = -\frac{Z_0}{3R + Z_0} \dot{U}_A \quad (5)$$

Substitute Z_0 into equation (5) to get:

$$\dot{U}_0 = \frac{-x_c^2 r(3R + r) + j3Rx_c r^2}{(3Rr)^2 + (3Rx_c + rx_c)^2} \dot{U}_A \quad (6)$$

\dot{U}_0 Lead \dot{U}_A ($180^\circ - \theta$) angle, where θ value is:

$$\theta = \arctg \frac{3Rr}{(3R + r)x_c} \quad (7)$$

$$\cos \theta = \frac{1}{\sqrt{1 + \left[\frac{3Rr}{(3R + r)x_c} \right]^2}} \quad (8)$$

$$\sin \theta = \frac{1}{\sqrt{1 + \left[\frac{(3R + r)x_c}{3Rr} \right]^2}} \quad (9)$$

The modulus of \dot{U}_0 is:

$$U_0 = \frac{U_A}{\sqrt{\left(\frac{3R}{x_c} \right)^2 + \left(\frac{3R}{r} + 1 \right)^2}} \quad (10)$$

Then the law of U_0 changing with parameters r , x_c and R is:

When the insulation resistance of the system to the ground remains unchanged, that is, r and R are fixed values,

$$U_0 = \frac{rU_A}{3R + r} \cdot \frac{U_A}{\sqrt{1 + \left[\frac{3Rr}{(3R + r)x_c} \right]^2}} = \frac{rU_A}{3R + r} \cos \theta \quad (11)$$

This is a polar coordinate equation. The diameter is $rU_A / (3R + r)$, and the diameter of the circle varies with different r and R , but both of them pass through the phasor \dot{U}_0 , and the circle family is inscribed on the circle point[5].

3. Detection method for insulation drop of mine cables

At present, the methods of insulation drop detection mainly include: DC superposition method, DC component method, DC component method, cable insulation dielectric loss method, grounding wire current, cable insulation online detection, wave current direction principle method, low-frequency overlapping method, etc. According to analysis and comparison, the method of additional signal is more suitable for the detection of cable insulation drop in coal mines. The DC component caused by the power frequency power supply of the additional DC mode has an impact on the additional signal, making the detection signal difficult to detect. There are two kinds of additional AC signals: high-frequency signal and low-frequency signal[6].

The mine power grid is a small current grounding system with ungrounded neutral point. The leakage current impedance is capacitive, and the capacitive impedance has the characteristics of reduced impedance for high frequency AC signals. Therefore, if the high-frequency AC signal is added, the leakage will not distinguish the additional signal from the detection signal. If low-frequency signal is used, the influence of capacitive reactance will be more obvious with the reduction of additional signal frequency, and the leakage current generated by the detection signal will not be affected. Considering the influence of capacitive current, this paper adopts the measurement method of 36 V, 10 Hz low-frequency signal superimposed on the line. Because the capacitive current is affected by the frequency reduction, but the resistive current changes little, it can be distinguished from the measured signal to realize the online monitoring of current insulation parameters[7].

The principle of the additional low-frequency signal method is to add a low-frequency signal source to the power grid, and its working principle is shown in Figure 3. In the figure, L1, L2 and L3 are the three branches of the power grid, C1, C2 and C3 are the distributed capacitance of the three branches to the ground, and r_1 , r_2 and r_3 are the insulation resistance of the three branches to the ground. The low-frequency signal generated by the low-frequency power supply is transmitted to the three-phase reactor SK through the isolation transformer, enters the power grid from SK, flows to the ground through the

ground capacitance C and insulation resistance r , and forms a loop with the sampling resistance R and the protection resistance J . The current transformers LH1, LH2 and LH3 obtain the corresponding current signals. Through calculation and processing, the cable insulation of each branch can be obtained, so that reliable fault line selection can be carried out[8].

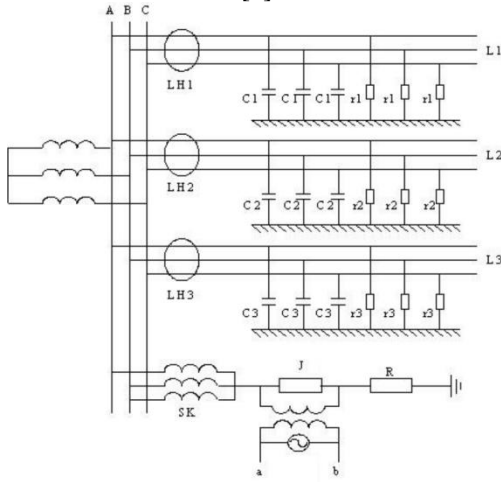

Figure 3. Principle of monitoring method for additional low frequency power supply.

Its equivalent circuit is shown in Figure 4. below.

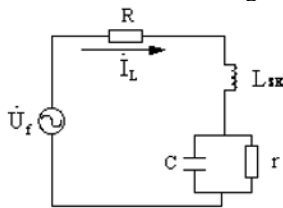

Figure 4. Equivalent circuit diagram of additional low-frequency power supply method.

The relationship can be obtained from Figure 4:

$$\dot{U}_f = \dot{I}_L(R + j\omega L_{SK}) + \frac{1}{\frac{1}{r} + j\omega C} \quad (12)$$

Where: \dot{U}_f is the additional low-frequency power supply voltage; \dot{I}_L is induced current of transformer; R is the resistance value of the sampling resistance; L_{SK} is the inductance value of three-phase reactor; r is the cable insulation resistance value.

Simplify equation (12) to obtain:

$$\dot{U}_f = \dot{I}_L \left[\left(R + \frac{r}{1+r^2\omega^2 C^2} \right) + j \left(\omega L_{SK} - \frac{r^2\omega C}{1+r^2\omega^2 C^2} \right) \right] \quad (13)$$

Take the mold from both ends of equation (13) to obtain:

$$U_f = I_L \sqrt{\left(R + \frac{r}{1+r^2\omega^2 C^2} \right)^2 + \left(\omega L_{SK} - \frac{r^2\omega C}{1+r^2\omega^2 C^2} \right)^2} \quad (14)$$

Formula (14) calculates and obtains the insulation resistance value. When r is smaller than the threshold value set by us, we can judge that the insulation decline fault has occurred in this branch, and we can conduct the fault outage operation.

Through research and analysis, the fault detection method has the following advantages: when the insulation decline fault occurs in a branch of the power grid, the branch current transformer can collect the low-frequency current signal, while the branch with normal insulation cannot collect the signal, so it can accurately determine the fault branch. The action threshold is only related to the low-frequency signal and the grounding resistance. As long as the appropriate current signal is selected, the reliable action of the monitoring system can be guaranteed[9].

4. Detection DECICE DESIGN

The system topology is shown in Figure 5. The core board adopts Univalent SEED-DPS2812; CPU main frequency 150MHz; Off chip SRAM: 256K × 16 bits; Off chip Flash: 256K × 16 bits; 32K maximum × 8-bit SPI serial interface EEPROM; Real time clock RTC+56 byte NvRAM; 18 bit, 580KSPS conversion rate chip A/D; 20 channels with photoelectric isolation switch input (12V~24V DC); 18 channels with photoelectric isolation switch output (5-40V DC); One circuit for isolated RS232/RS485 (isolation voltage 2500V); One way standard RJ45 linker; One channel eCAN transceiver driver, complying with CAN2.0 protocol; External connection 3 × 3 Keyboard; Self designed base plate: DIDO is completely photoelectric isolated; Including analog quantity acquisition input signal conditioning circuit[10].

The low frequency power supply design uses 51 series MCU to expand D/A output circuit to generate AC low frequency signal; 50Hz double T-notch filter, power amplifier, etc. constitute the power output signal conditioning board. The liquid crystal adopts DWIN64480010_WN.

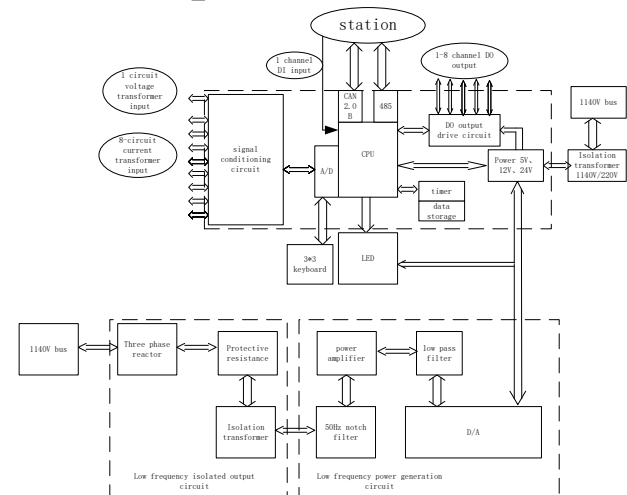

Figure 5. System topology diagram.

The independently developed signal conditioning module amplifies and filters the output signal of the leakage current transmitter. The principle is shown in Figure 6. The design adopts a super microcrystalline current transformer, a voltage forming circuit, a band stop filter, an amplifier circuit, and a band-pass filter to form

an analog quantity acquisition signal conditioning board. The circuit schematic diagram is as follows. The independently developed signal processing unit uses 16 bit AD for external sampling, which can process small changes in current.

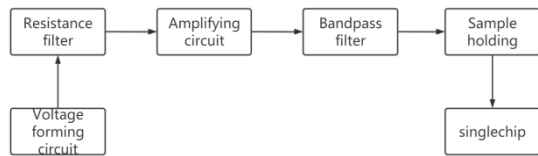

Figure 6. Schematic diagram of signal conditioning module.

Designed working voltage of monitoring equipment: AC660V (three-phase); Input apparent power: 250VA; Number of ports: 1 channel (transmitted with KT83-Z signal converter); Transmission mode: multi master, CAN; Transmission rate: 5 kbps; Transmission distance: 4km (MHYVR cable or MHYVP cable is used, and the conductor section is not less than 1.5mm²); Peak to peak voltage of communication signal: 1.5V ~ 5V. The substation is connected to the KT83-Z mining intrinsic safety signal converter through the CAN bus to realize the real-time diagnosis function of low-voltage power grid, and has the local LCD display function. When the insulation resistance of the monitored low-voltage network branch drops, the substation displays "insulation drop alarm", enters the alarm state, and informs the monitoring system of the fault branch, so as to judge the fault area and send out the fault area locking information. When the insulation resistance of the monitored low-voltage network branch circuit returns to normal, the substation displays "good insulation".

The purpose of the monitoring platform software for mine power grid line protection is to provide users with power cable insulation parameters for online monitoring, and to achieve various interfaces for power grid line protection functions. It has basic online monitoring function. It includes multi branch voltage, current, active power, reactive power, power factor and other parameters acquisition and display. The user can set any protection setting parameters by himself through the interface provided by the software, and then the system completes the monitoring process according to the setting values set by the user, and can automatically record the grid parameters at intervals or the current values that the user is interested in. In case of leakage fault (the collected value is greater than the set value), the software has the function of alarm and real-time fault value recording. Set the function manually. The setting function of online insulation monitoring alert threshold, selective leakage protection setting value and short-circuit protection setting value. Leakage protection line selection function, which is required to display the fault branch number. Display function of insulation resistance to ground. External equipment access support. In addition, it should also have perfect data management functions, configuration display and printing functions.

5. TEST

The simulation models of RLC circuit, power electronic circuit, motor control system and power system are built with the modules of SIMULINK Power System Blockset in MATLAB. The simulation model built mainly includes three phase source module, three phase transformer module, three phase series RLC load module, current measurement module, butterworth filter and scope module. Simulate the nested high-sensitivity current transformer on the power cable to detect the waveform of the power signal, distinguish the fault branch from the non fault branch, so as to selectively cut off the fault branch. Replace the parameters of the selected module and simulate the power frequency current detected by the zero sequence current transformer and the current detected by the non fault branch. Set simulation parameters of power cables in different coal mines to simulate the online monitoring system of insulation parameters of power cables. The simulation model of underground low-voltage power grid of coal mine is established, as shown in Figure7.

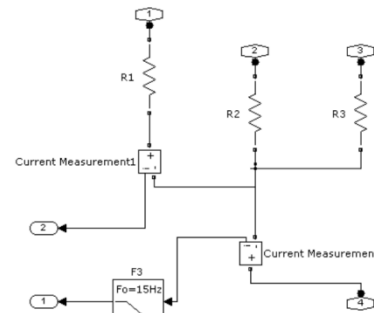

Figure 7. Simulation model for monitoring insulation parameters of low voltage power network in coal mine.

High precision power cable fault test system, large current generator, power cable insulation leakage detection device, mine shielded communication cable, etc. are used to establish the mine cable insulation value test system.

The main feed leakage protection is completed by detecting the DC power supply to the ground. When the insulation resistance to the ground is small to a certain value, the switch will be locked for leakage. After the switch works normally, when the load side line's leakage resistance to the ground is small to a certain value, the switch will act quickly, and the action time is within 200ms. The action time will be greater than the 50ms range when the sub feed is working. The time intervals for the main/sub feed longitudinal leakage protection are staggered, When the load side of the sub switch leaks electricity, the total feed will not malfunction.

In the 1K leakage test on the load side of the main feed, first press the selection on the dial of the main feed test cabinet and press the 0.22 micro method or 0.47 micro method or 1.0 micro method capacitance to ground. If the capacitance to ground is large, the line is long. When the 1K leakage test button is pressed, the leakage current to ground and the switch action time can be observed. The product of current and time should not be greater than 30mAs because the three-phase reactor of the

switch under test has the compensation performance for the capacitive current, From the test, it can be seen that the load circuit of the switch should not be too long, which will cause large leakage current. Increase the risk of electric shock. The leakage at the load side of the total feed shall not cause any branch feed action at the load side.

The experimental results show that whether for single branch insulation decline, leakage fault, or decentralized insulation decline, leakage fault, if the traditional selective leakage protection using the bus current fault characteristic as the criterion is simply used, there are some limitations. The differential selective leakage protection technology of zero sequence power direction type based on low-frequency superposition method can accurately identify the fault characteristics, correctly reflect the fault type, achieve the requirements of online acquisition of cable insulation parameters, and timely eliminate the leakage fault in the embryonic stage.

6. CONCLUSION

By analyzing all kinds of fault information and its characteristic laws after the grounding fault occurs in the power supply system, the common algorithms are compared and evaluated. On this basis, the method of online monitoring of power cable insulation parameters is studied, and the method of adding low-frequency signal power supply is proposed for online monitoring of power cable insulation parameters, and the database of power cable distribution parameters is established, The principle of zero sequence power direction is used to realize the grounding protection of power supply system.

The system can monitor the insulation condition of cables online when the power grid is in operation. It can not only monitor the insulation level of the whole system, but also monitor the insulation condition of each outgoing line, greatly improve the safe operation level of the power grid, replace preventive maintenance, and eliminate the fault phenomenon caused by extreme weakness in the bud, which is of great significance.

Acknowledgment

General project of special project of science and technology innovation and entrepreneurship fund of Tiandi Technology Co.Ltd,2022-2-TD-MS003.

References

- [1] Cen Feng,Wang Guanghui.Boosting Occluded Image Classification via Subspace Decomposition-Based Estimation of Deep Features[J].IEEE Transactions on Cybernetics. 2019 (7):130-137
- [2] Thangarajah Akilan,Qingming Jonathan Wu,Hui Zhang.Effect of fusing features from multiple DCNN architectures in image classification[J].IET Image Processing. 2018 (7):190-195
- [3] Jiuxiang Gu,Zhenhua Wang,Jason Kuen,Liayang Ma,Amir Shahroudy,Bing Shuai,Ting Liu,Xingxing Wang,Gang Wang,Jianfei Cai,Tsuhan Chen.Recent advances in convolutional neural networks[J]. Pattern Recognition. 2018:22-27
- [4] Yun Ren,Changren Zhu,Shunping Xiao. Small Object Detection in Optical Remote Sensing Images via Modified Faster R-CNN[J].Applied Sciences. 2018 (5):67-72
- [5] Nirwan ANSARI,Xiang SUN. Mobile Edge Computing Empowers Internet of Things[J].IEICE Transactions on Communications. 2018 (3):110-115
- [6] Sachin Sharma,K.R. Niazi,Kusum Verma,Tanuj Rawat.Coordination of different DGs, BESS and demand response for multi-objective optimization of distribution network with special reference to Indian power sector. International Journal of Electrical Power and Energy Systems. 2020 (C):31-35
- [7] Yue Yang,WenChuan Wu.IEEE Trans.A Distributionally Robust Optimization Model for Real-Time Power Dispatch in Distribution Networks. Smart Grid. 2019 (4):78-91
- [8] M.T.L. Gayatri,Alivelu.M. Parimi,A.V. Pavan Kumar.A review of reactive power compensation techniques in microgrids. Renewable and Sustainable Energy Reviews. 2018:113-118
- [9] Mehdi Mehdinejad,Behnam Mohammadi-Ivatloo,Reza Dadashzadeh-Bonab,Kazem Zare.Solution of optimal reactive power dispatch of power systems using hybrid particle swarm optimization and imperialist competitive algorithms. International Journal of Electrical Power and Ene. 2016:27-31
- [10] Jirawadee Polprasert,Weerakorn Ongsakul,Vo Ngoc Dieu.Optimal Reactive Power Dispatch Using Improved Pseudo-gradient Search Particle Swarm Optimization. Electric Power Components and Systems. 2016 (5):91-96