

# Effect of perforation shear on viscosity of polymer solution

Xi Yan<sup>1,2</sup>, Xiaoyan Wang<sup>1,2</sup>, Wei Wang<sup>1,2</sup>, Zeyu Lin<sup>1,2</sup>, Guangyu Yuan<sup>1,2</sup>, Nan Zhan<sup>1,2</sup>, Song Han<sup>3</sup>, Xidong Cai<sup>4</sup>, Xing Wu<sup>1,2</sup>, Yanbin Liang<sup>1,2</sup>

<sup>1</sup> Oil Production Technology Institute, PetroChina Dagang Oilfield, Tianjin China

<sup>2</sup> Key Laboratory of Nano-chemistry, CNPC, Tianjin, China

<sup>3</sup> The Fifth Oil Production Plant, PetroChina Dagang Oilfield, Tianjin, China

<sup>4</sup> Exploration and Development Research Institute, Tuha Oilfield, CNPC, Xinjiang, China

**Abstract:** Polymer flooding is a tertiary oil recovery technology that is very suitable for the characteristics of China's reservoirs. However, due to the fast flow rate of polymer solution in near-well zone, the shear effect of perforation blasthole and the compacted zone results in serious loss of polymer viscosity. In this paper, the polymer used in Dagang Oilfield is studied by simulation experiment through the shearing process of perforating holes, and the influence of different perforating parameters on polymer viscosity loss is analyzed, so as to provide theoretical basis for the optimization design of perforating technology in field test. The experimental results show that, the shear effect of perforation blasthole on polymer is not obvious, and the viscosity retention rate of polymer solution is greater than 96%. The size and shape of perforation blasthole have no effect on viscosity loss of polymer solution. The shear effect of compacted zone on polymer is obvious, and the viscosity retention rate of polymer solution is lower than 64% for the target block. The viscosity loss of polymer solution increases with flow rate at compacted zone, and the decrease of permeability can increase viscosity loss of polymer solution. The higher the polymer concentration is, the stronger the shear resistance is, while the higher the molecular weight is, the weaker the shear resistance is. It is suggested that perforation gun and perforation method with deep perforation depth and low compaction degree be chosen to reduce the flow rate at compacted zone and viscosity loss of polymer solution.

**Key words:** Perforation blasthole; compacted zone; shear effect; polymer viscosity loss; perforation parameter

## 1. Introduction

The industrial application of polymer flooding in China has been more than 20 years, and it has been proved to be a tertiary oil recovery technology suitable for the characteristics of oil reservoirs in China[1-4]. After polymer solution is injected into reservoir, effects relating to increasing the viscosity of water phase and polymer retention cause the decrease of permeability to improve the oil-water mobility ratio and adjust the water injection profile, which can further expand the swept volume and improve the crude oil recovery[5-6]. Therefore, after polymer solution is injected into the reservoir, the retention of solution viscosity has a great impact on polymer flooding effect[7-10].

The polymer solution is subject to continuous shearing during preparation and injection, resulting in the loss of solution viscosity. Researchers from Clausthal University of Technology in Germany pointed out that polymer for EOR will suffer mechanical shear in the whole process from ground to reservoir, such as preparation (agitator), transportation (pipeline components, pumps, valves),

injection (casing holes) and flowing through porous media[11-12]. According to statistics, the total viscosity loss of polymer solution from the injection well to the detection well can reach as high as 66.7%. While the flow velocity near the well is faster than other process, and the viscosity loss caused by perforation and borehole shearing can be more than 28.8%, which reduces the ability of polymer to establish flow resistance and improve swept volume in the formation[13-14]. Therefore, this paper mainly focuses on the polymer used in the medium to high permeability and medium temperature reservoirs of Dagang Oilfield. The research about polymer shearing process through perforating blastholes is carried out to analyze the impact of different perforating parameters on polymer viscosity, and further provides a theoretical theory for the optimization design of perforating technology in field development.

## 2. Physical Model Design of Perforating Hole Structure

The near well zone in reservoir is an area where the fluid regime is complex, such as linear flow, radial flow, spherical flow. Meanwhile, the distribution of flowing medium is also complicate in this area, including wire wound screen, gravel packing layer, perforating hole and compaction zone, formation pore. According to the principle of similarity, the same or similar medium can be gotten by transforming the complex spherical flow and radial flow into simple one-dimensional linear flow. The shearing degree of polymer flowing near the well depends on the flowing medium and rate. Therefore, the design principles of the physical model in this paper are: first, the flow rate of polymer in the model is the same as velocity in the actual reservoir. Secondly, the medium in the model is the same or similar to the actual medium. Through investigation, it is found that the main perforation factors affecting the polymer effect are: perforation density, aperture, hole depth, phase angle, hole shape, compaction degree of perforation compaction zone, compaction thickness of perforation compaction zone, pollution zone depth. Based on the above principles and influencing factors, this paper has established a physical model of perforating blasthole structure, as shown in Figure 1, which divides the perforation blasthole structure into blasthole part (Zone I) and compaction zone (Zone II).

For the simulation of borehole shearing, indoor simulation models of perforating blastholes with different apertures, shapes and chamfers are designed, as shown in Figure 2 which is a schematic diagram of a physical model of the blasthole. The hole shape is round with 45 ° chamfer, and the aperture is 13mm. The effects of perforation diameter, shape (shape and chamfer), and density on polymer solution shear were studied. For the simulation of shearing in compaction zone, cores with different porosity and permeability are selected, and the core length is designed to simulate the thickness of compaction zone equivalently. The core porosity and permeability are equivalent to characterize the average porosity and permeability of compaction zone to study the shear effect of compaction zone on polymer.

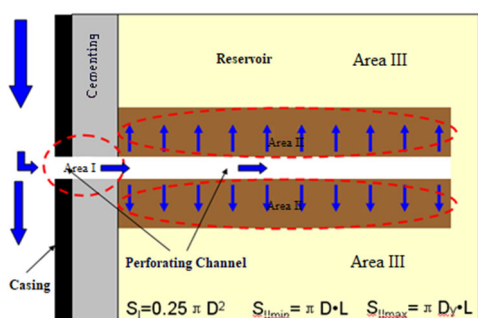

Figure 1 Schematic diagram of single hole injection fluid flow area

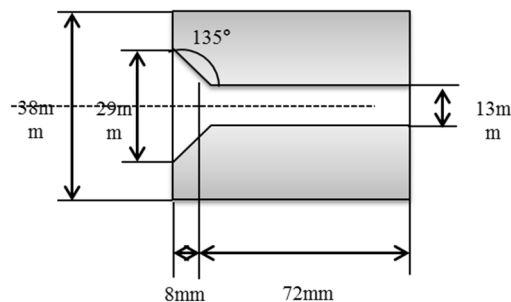

Figure 2 Simulated perforation model

(13 mm diameter, circular 45° chamfering)

### 2.1 Experiment Process of Shear Degradation of Polymer through Perforation

Based on the similarity criterion that the flow velocity at the perforation is consistent, the experiment flow chart of the hole shear is designed as shown in Figure 3. The specific experimental methods and steps are: 1) Preparation polymer solutions with different molecular weights and concentrations and measure the viscosity. 2) At 53 °C, the polymer solution is stably passed through the perforation-simulated device to measure the viscosity of the solution after shearing; 3) Calculate the viscosity loss of polymer solution before and after shearing.

### 2.2 Experimental Process of Polymer Degradation due to Shear in Compacted Zone

In this paper, the process of shear simulation experiment in perforated compaction zone is established as shown in Figure 4. Cores with different parameters are selected to simulate compaction zones with different compaction degrees, which are characterized by the permeability after compaction. Specific experimental methods and steps are as following: 1) Prepare polymer solutions with different molecular weights and concentrations, and measure the viscosity of the solution; 2) The polymer solution is stably passed through the simulated compaction belt device at 53 °C to measure the viscosity of the solution after shearing; 3) Calculate the viscosity loss of polymer solution before and after shearing.

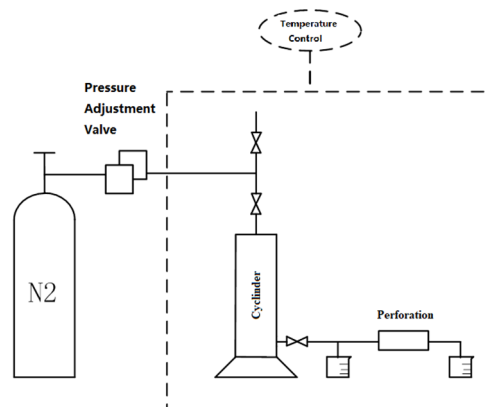

Figure 3 Flow chart of shear simulation experiment in simulated perforation model

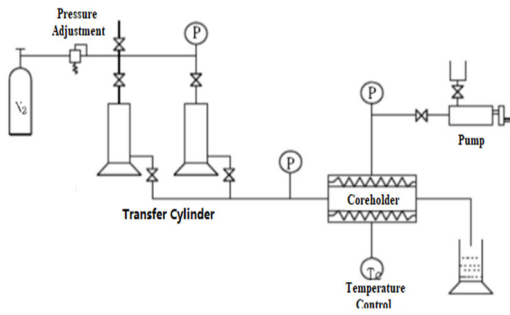

Figure 4 Flow chart of simulating shear test in compacted zone

### 3. Results and Discussion

#### 3.1 Shearing Passing through Perforation

The experiments were carried out under the conditions of different pore diameters (1mm, 2mm, 6mm, 13mm), different pore shapes (round, square, round - 45° chamfer), different molecular weights (25 million, 30 million) and different solubility (1500mg/L, 2000mg/L) in order to analysis these factors' impact on polymer viscosity.

##### 3.1.1 Perforation Diameter

The polymer solution with a concentration of 1500mg/L prepared by 25 million molecular weight polymer was used to conduct shear experiments under different round and square perforation shape. The experimental results are shown in Figure 5-6. Under the two perforation diameters, the relationship between viscosity loss and flow rate is basically the same. The greater the flow rate, the greater the viscosity loss caused by the cutting of perforation. Under the same flow rate, the viscosity loss caused by different perforation diameters is similar. Therefore, the perforation diameter has little effect on the shear of polymer solution. For example, in Gangxi polymer injection test area, the velocity near perforation is about 5500m/d, and the viscosity loss of corresponding polymer solution is below 4%.

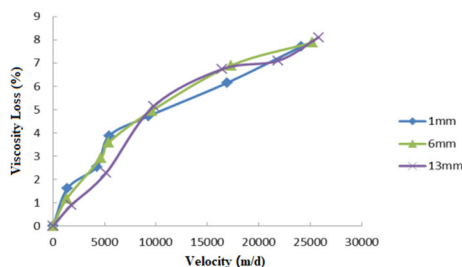

Figure 5 The relationship between velocity and viscosity loss under different diameter (circular)

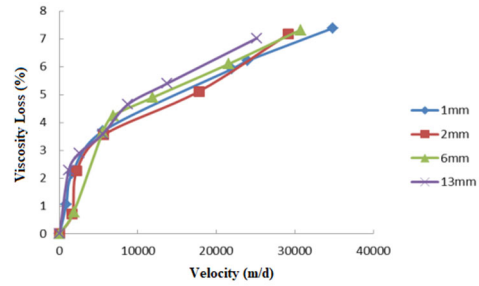

Figure 6 The relationship between velocity and viscosity loss under different diameter (square)

##### 3.1.2 Perforation Shape

The polymer solution with a concentration of 1500mg/L prepared with a 25 million molecular weight polymer was used to conduct the shear test under the condition of no chamfer in 1mm (round and square) perforation with different shapes. The results are shown in Figure 7. At the same flow rate, the viscosity loss of polymer solution is basically not affected by different shapes of perforations. With the increase of flow rate, the viscosity loss of both types of perforations increases, and the influence of round perforations on the viscosity loss of polymer solution is slightly lower than that of square perforations.

Figure 8 shows the change of viscosity loss when comparing the round perforation (an aperture of 13mm) with or without chamfer. It can be seen that at the same flow rate, the shearing effect of the chamfered hole on the polymer solution is significantly reduced, and the existence of chamfer can reduce the viscosity loss by more than 20%.

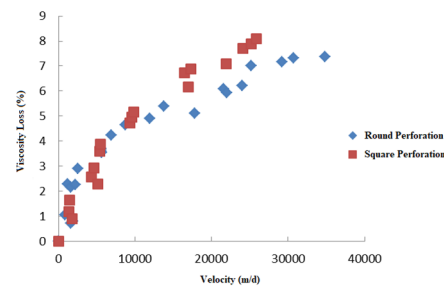

Figure 7 The relationship between velocity and viscosity loss under different shaped perforations

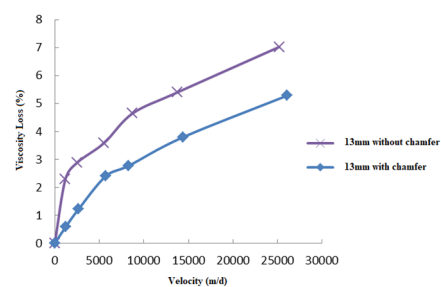

Figure 8 The relationship between velocity and viscosity loss under different chamfered perforations (circular)

### 3.1.3 Concentration and Molecular Weight of Polymer

Figure 9 shows the shear test results of polymer solutions with different concentrations (1500mg/L, 2000mg/L) prepared with a molecular weight of 25 million under a round 13mm diameter perforation. At the same flow rate, 2000mg/L polymer solution has a better shear resistance, and the viscosity loss of 2000mg/L polymer solution is obviously lower than 1500mg/L polymer solution. The higher the concentration of polymer solution is, the more tightly the molecular strands are intertwined, the less the damage of shear on the winding point is, and the stronger the shear resistance is.

Figure 10 shows the shear test results of 1500mg/L polymer solution prepared by 25 million molecular weight polymer and 30 million molecular weight polymers respectively under 13mm hole diameter round perforation. At the same flow rate, the viscosity loss of polymer solution with low molecular weight is obviously lower, and the maximum reduction can reach 30%, which illustrates that the shear resistance is better. The larger the molecular weight of the polymer, the more uneven the distribution of the long and short links of its molecular chain. When subjected to shearing, the molecular chain is stretched, and the distance between the long and short links increases. Therefore, the intertwining points between the links are greatly reduced, and the probability of the long links being sheared increases. The high molecular weight polymer is severely damaged by shearing, and its shear resistance is poor.

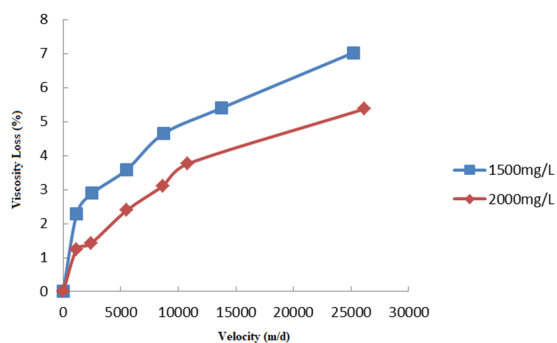

Figure 9 The relationship between velocity and viscosity loss under different polymer concentrations (Molecular weight=25 million)

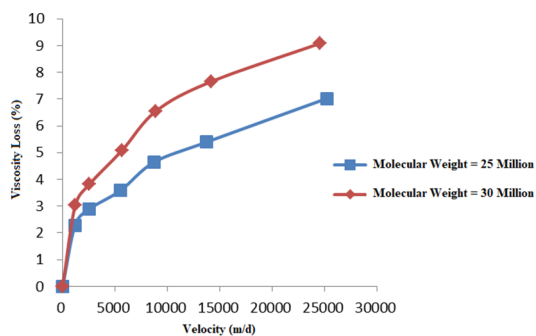

Figure 10 The relationship between velocity and viscosity loss under different molecular weight (Polymer concentration=1500 mg/L)

### 3.2 Shearing in Compaction Zone

Different lengths and permeability are selected. By changing the velocity, shear experiments in compaction zone under different molecular weight (25 million, 30 million) and concentration (1500mg/L, 2000mg/L) are conducted to analyze the influence of different factors on polymer viscosity. The concept of pore velocity is introduced:

$$V = \frac{Q}{\pi \times \phi \times D \times Sd \times Pd \times T}$$

Which, Q—Injection velocity; V—Real velocity in pore structure;  $\phi$ —Porosity; D—Perforation diameter; Sd—Shot density; Pd—Perforation depth; T—Thickness of perforated well section

#### 3.2.1 Compaction Degree

A polymer solution with a molecular weight of 25 million was used to prepare a concentration of 1500 mg/L. When the compaction thickness was 1.25 cm, shear tests were conducted at different compaction degree (169 mD, 178 mD, 330 mD, 537 mD, 891 mD). The viscosity loss were shown in Figure 11. With the increase of flow rate, the viscosity loss of polymer increases gradually. When the flow rate reaches a certain extent, the viscosity loss tends to be gentle (the highest viscosity loss reaches 64%); At the same pore velocity, different compaction degrees are more sensitive. The greater the compaction degree (the smaller the permeability), the greater the impact of the compaction zone on the viscosity loss of polymer solution.

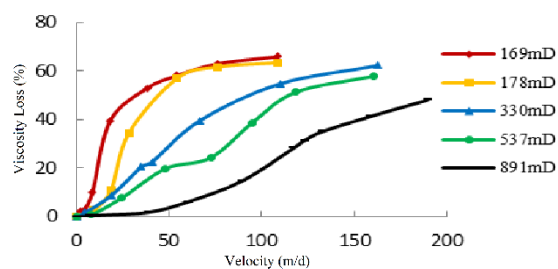

Figure 11 The relationship between velocity and viscosity loss under different permeability

#### 3.2.2 Compacted Thickness

A polymer solution with a molecular weight of 25 million is used to prepare a concentration of 1500 mg/L. When the compaction degree is 169 mD, shear tests are carried out under the compaction bands with different compaction thicknesses (1.10cm, 1.25 cm, 1.55 cm). The viscosity changes are shown in Figure 12. With the increase of velocity, the viscosity loss in compacted zone with different compaction thickness increases. At the same compaction degree and flow rate, the greater the thickness of the compaction zone, the longer the migration distance in the porous medium, and the greater the shear effect, so the greater the impact on the viscosity loss of the polymer solution.

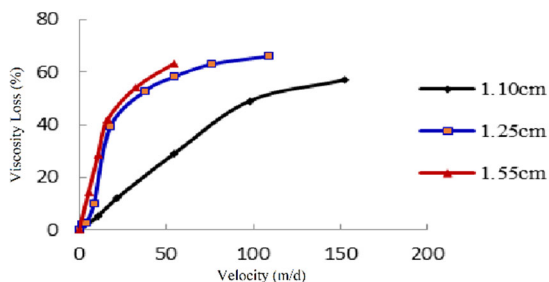

Figure 12 The relationship between velocity and viscosity loss under different thickness of the compacted zone

### 3.2.3 Polymer Concentration

The Gangxi polymer solution with different concentrations (1500mg/L, 2000mg/L) was used to conduct shear experiments under the compaction with thickness of 1.25cm (as shown in Figure 13). The results showed that under the same shear conditions, the higher the concentration of polymer solution, the lower its viscosity loss and enhanced its shear resistance.

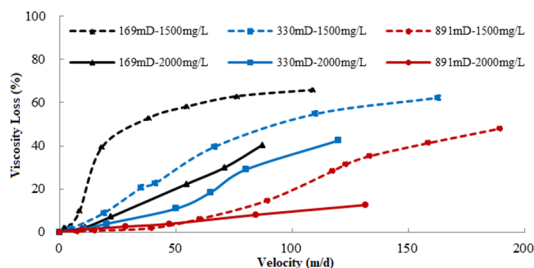

Figure 13 The relationship between velocity and viscosity loss of polymer with different concentration after sheared by compacted zone

### 3.2.4 Molecular Weight

Comparing the 2000mg/L solution prepared by 25 million and 30 million polymer, the shear results of the 1.25cm thick compaction zone are shown in Figure 14. Under the same pore flow rate and compaction conditions, the viscosity loss rate of 25 million polymer solution is obviously lower than that of 30 million polymers. The smaller the polymer molecular weight, the better its shear resistance.

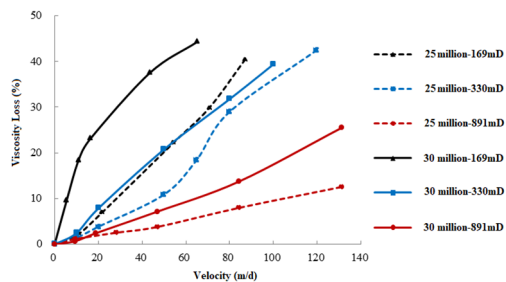

Figure 14 The relationship between velocity and viscosity loss of polymer solutions (made of different molecular weights, 2000 mg/L)

(1) The effect of perforation on polymer shear is not obvious (viscosity retention is greater than 96%); The bigger the velocity of the blast hole is, the greater the viscosity loss of polymer solution is. The size and shape of perforation have little effect on the viscosity loss;

(2) The compaction zone has obvious shear effect on polymer. With the increase of velocity, the degree of compaction (the lower the permeability) and the compaction thickness, the viscosity loss rate of polymer solution increases rapidly. Therefore, final viscosity retention rate of polymer solution tends to be gentle (under the condition of pore flow velocity in the target block, the minimum viscosity retention rate is only 36%).

(3) The higher the polymer concentration, the stronger the shear resistance. While the higher the polymer molecular weight, the weaker the shear resistance;

(4) When designing the perforation process of injection wells in the polymer injection test area, the perforating cartridge and perforation mode with large perforation depth and low compaction degree should be selected as far as possible to reduce the pore flow rate at the compaction zone and reduce the viscosity loss of polymer solution caused by the compaction zone.

## References

1. Wang Demin. Cheng Jiecheng. Wu Junzheng. Wang Gang. Application of polymer flooding technology in Daqing Oilfield[J]. Acta Petrolei Sinica. 2005.26(1):74-78.
2. Gao Yan. Wang Qingping. Zhou Zongming. Zhang Aimei. Yao Huili. Effect of polymer injection rate on EOR[J]. Petroleum Geology And Recovery Efficiency.2001.8(2):64-66
3. Han Ming. Bai Baojun. Niu Lujie. Zhang Yanfu. Gao Yujun. Performance evaluation of polymer flooding in fault block Jin 16 [J]. Oil & Gas Recovery Technology.1999(3):1-6
4. Luo Pingya. Li Huabin. Zheng Yan. Liao Guangzhi. Yang Zhenyu. EOR by ASP of Hydrophobic Associated Polymer-Alkali-surfactant in Daqing Oil Field[J]. Petroleum Geology & Oilfield Development In Daqing.2001. 20(6):1-4
5. Hill H J, Brew J R, Claridge E L, et al. The Behavior of Polymers in Porous Media[C]// SPE Improved Oil Recovery Symposium. Society of Petroleum Engineers, 1974.
6. Martin F D. Laboratory investigations in the Use of Polymers in Low Permeability Reservoirs[J]. 1974 .
7. Martin F D. Mechanical Degradation of Polyacrylamide Solutions in Core Plugs From Several Carbonate Reservoirs[J]. Spe Formation Evaluation, 1986, 1(2):139-150.
8. Maerker J M, Maerker J M. Shear Degradation of Partially Hydrolyzed Polyacrylamide Solutions[J]. Society of Petroleum Engineers Journal, 1975, 15(4):311-322.

## 4. Conclusion

9. LuXiangguo. Yan Wenhua. Song Helong. Gao Zhenhuan. An Experimental Study On Shear Degradation Of HPAM Solutions Flowing Through Porous Media[J]. Oilfield Chemistry.1995(4):375-378
10. Shao Zhenbo. Zhou Jisheng. Sun Gang. Niu Jingang. Liu Fengqi. Han Zhaorang. Studies on Mechanical Degradation of Partially Hydrolyzed Polyacrylamide in Course of Polymer Flooding: Changes in Relative Molecular Mass, Viscosity and Related Parameters[J]. Oilfield Chemistry.2005.22(1):72-77
11. An Yongsheng. Liu Wenli. Qi Xiangwen. Influence of perforation parameter on productivity of horizontal well[J]. Fault-Block Oil And Gas Field.2011.18(4):520-523
12. Chen Huijun. Wu Liqiang. Zhang Jun. Wei Nanning. Hu Yuzhong. Investigation into the viscosity loss of polymer solutions through different diameter nozzles[J]. Journal Of Daqing Petroleum Institute. 1999.23(3):224
13. Smith J E. Closing the Lab-Field Gap: A Look at Near-Wellbore Flow Regimes and Performance of 57 Field Projects[J]. 1994.
14. OSTERLOH.W. T. E. J. Polymer transport and rheological properties for polymer flooding in the North Sea Captain field[J]. Oil Field.1998.