

# Study on the combined use of solar and water energy in power supply systems

*Dilshod Kodirov*<sup>1\*</sup>, *Gulmurod Kushakov*<sup>2</sup>

<sup>1</sup>Department of Power Supply and Renewable Energy Sources, National Research University TIAME, 100000 Tashkent, Uzbekistan

<sup>2</sup>Jizzakh Polytechnic Institute, Jizzakh, Uzbekistan

**Abstract.** This article discusses the development of a system for the combined use of solar and water energy based on a systematic approach to power supply. An improved physical model has been developed based on a model for predicting the production of electricity, taking into account the power and time of solar radiation, the amount and speed of water flow. At the same time, the share of electricity in the use of solar and water energy was determined simultaneously, depending on the conditions for the uninterrupted supply of consumers with the daily necessary electricity. The assessment of indicators of the combined use of solar and water energy and the definition of energy efficiency were developed by the authors on the basis of an increase in the share of electricity obtained from renewable energy sources in the electricity supply, which is explained by the coincidence of theoretical and experimental results.

## 1 Introduction

Most districts are supplied with electricity on the basis of a centralized system. The choice of traditional sources in the power supply system is based on the capacity of the available energy sources. At the same time, the power supply does not always fully meet the requirements of consumers. According to the existing literature [1, 2, 3, 4], the use of renewable energy sources for power supply really contributes to the conservation of hydrocarbon reserves. Potentially available types of energy in all regions of our country are solar energy and water energy. Using them as the main source of electricity increases the efficiency of the power system. Non-renewable and renewable energy sources can be used separately or together.

The level of development of renewable energy sources is much higher than that of traditional energy. Significant development is observed in the field of solar, wind and small hydropower in the republic. In general, in 2022-2025, it is planned to build 10 solar and wind power plants with a total capacity of 3,000 MW (see Figure 1). These figures continue to increase from year to year. Much has been said about the prospects of renewable energy sources. For example, the amount of radiation energy coming from the Sun to our planet is on average 1.3-1.4 kW/m<sup>2</sup>. If we do not take into account the amount of radiation returning from the atmosphere, then an average of 1 kW/m<sup>2</sup> of energy falls on the earth's surface. This energy is 9,000 times greater than the current energy needs of our planet. For this reason, it will be correct to realize newly added energy capacities from renewable sources, and not from traditional energy.

---

\*Corresponding author: [kodirov.dilshod@gmail.com](mailto:kodirov.dilshod@gmail.com)

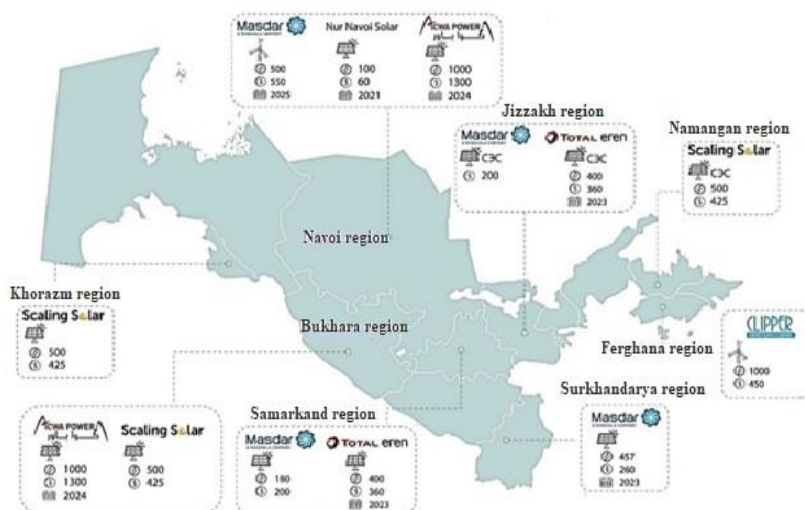

Fig. 1. Projects implementation target in Uzbekistan until 2025

## 2 Methods

It will be necessary to develop a method for correctly selecting the source of energy consumed in a system that works in conjunction with centralized electrical networks. It is necessary to develop a single model that correlates with the methods identified to date. On the basis of a four-stage system, the main stages of research are shown to determine the share of electricity in the use of solar and water energy at the same time, depending on the conditions for the constant supply of consumers with the daily required electricity. The proposed four-stage research model can be summarized as follows [3]:

- ensuring uninterrupted power supply using renewable energy sources in agriculture and water management;
- estimate the amount of electricity being replaced by non-traditional power supply;
- The full use of renewable energy in electricity supply is carried out in two stages, namely:  
a) study of the operating modes of consumers of agriculture and water management; b) development of a technical solution for the combined use of solar and water energy;
- develop a model for choosing the right combination of traditional and non-traditional energy sources for power supply [4].

At the first stage, a system of joint or separate use of renewable and non-renewable energy sources for electricity supply to agriculture and water management will be developed. When developing this method, taking into account the location of agricultural and water facilities in different regions, a renewable energy source with high potential near the consumer is used. The necessary electricity for consumers of agriculture and water management can be obtained from renewable energy sources, and the rest can be obtained from centralized electrical networks [5]. To do this, it is necessary to develop a calculation model for determining the amount of energy consumed from renewable energy sources in power supply. The power supply system will be designed taking into account the conditions for the use of renewable energy sources.

At the next stage, ways of continuous supply of electricity from renewable sources will be considered, taking into account the operating modes of consumers. When developing this method, it is necessary to evaluate the possibilities of using renewable energy sources in the power supply of agriculture and water management by adapting the power supply to the operating modes of consumers. At the same time, the issues of determining the parameters of continuous and high-quality power supply to consumers and the replacement of traditional energy supply with non-traditional energy are considered. At this stage, it is

important to calculate the share of electricity that is being replaced by non-traditional electricity supplies from traditional electricity supplies to consumers.

At the third stage, the power supply system is studied and a model for the use of renewable resources in the power supply system is developed. At this stage, the conditions for the use of solar and water energy are modeled and the energy properties of the energy source will study. It is important to take into account the random change in the energy intensity of renewable energy sources. It is necessary to bring the parameters of energy received from a renewable source to the optimal system in order to coordinate them with the operating mode and energy-intensive process parameters. A model for the joint operation of solar and hydroelectric power plants will be developed based on two types of sources with a high energy potential of renewable energy sources. Based on the analysis of the studies carried out on the simultaneous use of solar and water energy, the main energy indicators of a renewable resource are determined.

In the last step, an improved physical model will be developed based on the adaptation of the dimensions of the details of the combined technical solution for the combined use of solar and water energy to the agriculture and water supply system. Additional resources in the traditional power supply system serve to increase its efficiency. Then, based on the criteria for the rational integration of consumed energy resources, the price of electricity consumed in the electricity supply through the use of renewable energy sources is determined. In this case, it is necessary to develop a model of the interdependence of traditional and renewable energy in the energy supply of consumers based on acceptable parameters [6].

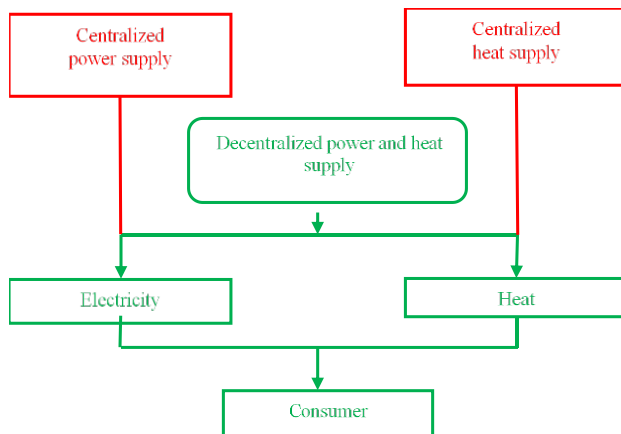

**Fig. 2.** Centralized and decentralized power supply scheme

The development of a decentralized electricity supply system from renewable energy sources is an important issue in the cultivation and storage of cash crops in agriculture [7]. Each energy system has its own purpose and, according to the hierarchy, is subordinate to the main task of the system. The energy resource system can only affect targets in combination with other relevant systems. To do this, we will need to consider the entire power generation system.

A complete analysis of energy losses in the process of extraction, supply and combustion of energy resources used in traditional power plants is presented. Therefore, the main goal of the power supply system based on renewable energy sources is to save energy resources and organize the production of electricity at minimal cost [8]. The energy resource system provides consumers with energy from various sources. Figure 2 shows diagrams that allow to provide technological processes with electrical and thermal energy.

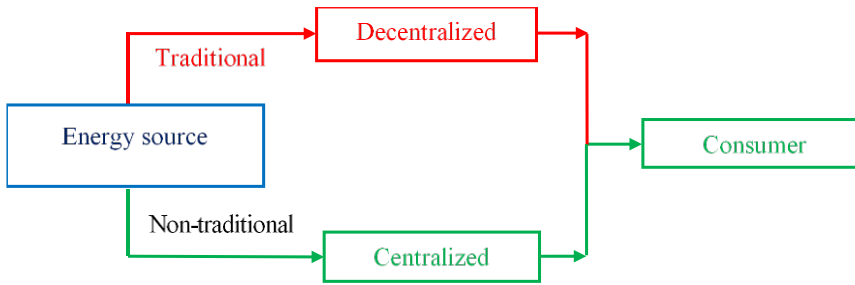

**Fig. 3.** Scheme of energy supply to consumers

In general, it is necessary to provide electricity and heat supply for agriculture and water management in combination with centralized and decentralized systems. The power supply system is decentralized, but the power supply scheme associated with the centralized system is complex. A block diagram of the use of traditional and non-traditional energy in the power supply system is shown in Figure 3 [9]. In a centralized and decentralized energy supply scheme, electricity can be obtained from traditional or non-traditional energy [10]. As a renewable energy source, various types of energy can be represented as follows:

$$\sum_{i=1}^n E_{m,i} = \sum_{i=1}^n E_{m,i} e_{m,i} + \sum_{i=1}^n E_{m,i} i_{m,i}, \quad (1)$$

here,  $E_{m,i}$  – the amount of energy received from decentralized renewable energy sources;  $e_{m,i}$  – and  $i_{m,i}$  – amount of electrical or thermal energy. [10].

In power supply, the consumption of electrical and thermal energy should be equal to the load value:

$$E_C = E_{RES} + E_{EL} + E_{HE} \quad (2)$$

here,  $E_{El}$  – electricity,  $E_{HE}$  – heat energy,  $E_{RES}$  – renewable energy source [11].

The power supply of agriculture and water management is associated with changes in weather conditions, irrigation regimes, growing crops, their storage, processing and other energy costs. The current power supply is based on conventional thermal power plants, fully connected to the centralized power grid. Interruptions in the existing system, poor quality power supply and frequent price increases are the basis for finding the best solution. In this case, a renewable energy system may be the solution. A conventional system is not required when a renewable power supply is available. The studied agricultural consumers can be provided with energy, including from renewable energy sources, due to their different power.

The light energy returned from the surface of the panels is not used to generate electricity. Therefore, when installing solar panels on a farm, must rely on a professional project. After all, the design that suits your neighbor does not suit your home. To do this, the place where solar panels will be installed on the roof must have conditions for obtaining maximum energy (radiation) from the sun during the day in an upright position (depending on the time of year). An important role in this is played by the installation angle of the panels and the configuration of the panels. An important role in this is played by the installation angle of the panels and the configuration of the panels. If special instruments and satellite data are used in the implementation of these calculations, and if the measurement is carried out very accurately, the final result will be close to the real value.

System integrity plays an important role in research. Power supply is characterized by new properties that are not specific to individual parts (elements), but arising as a result of their interaction. In this case, the potential of a renewable energy source in the area where the consumer is located is studied, decentralized power supply is organized based on the source with the greatest potential. The energy that the consumer lacks can be obtained from the centralized power supply. The choice can be made by attracting additional renewable

sources, taking into account the capacity of the existing heat supply system. At the same time, the amount of energy consumed can be provided on the basis of centralized and decentralized power supply [12]:

$$E_C = E_{EL}(E_{RES}) + E_{HE}(E_{RES}) + \sum_{i=1}^n E_{m.i} \tag{3}$$

For the rational use of energy resources, it is necessary to determine the importance and place of renewable sources in an integrated power supply system. At the same time, it is necessary to consider the most convenient renewable sources for the consumer, as well as to study the possibilities of using solar and hydropower in the energy supply of consumers. For electricity and heat supply - based on the experience of using renewable sources, solar collectors are used for heat supply, and small hydroelectric power plants are used for electricity supply. Electricity consumption is obtained from centralized and decentralized energy supply:

$$E_{EL} = E_{m.i}e_{m.i} + E_{RES} \tag{4}$$

In accordance with the above, heat supply can also be obtained from centralized and decentralized energy supply:

$$E_{HE} = E_{m.i}i_{m.i} + E_{RES} \tag{5}$$

here,  $E_{EL}, E_{HE}$  – consumption of electrical and thermal energy [13].

Since renewable energy sources are considered as the main source of electricity for agriculture and water supply, the amount of electricity required by the consumer ( $Q_i$ ) is selected from several energy sources with the greatest potential:

$$E = \left\{ \begin{array}{l} E_{TE} \\ E_{TE} + E_{HP} \\ E_{TE} + E_{SE} \\ E_{TE} + E_{HP} + E_{SE} \end{array} \right\} = E_C \tag{6}$$

Then the energy consumed from the traditional source:

$$E_{TE} = E_C - \sum_{i=1}^n E_{RE.i} \tag{7}$$

The share of traditional sources in the power supply system of consumers of agriculture and water management depends on the conditions for the use of renewable sources. At the same time, traditional sources serve to ensure the reliability of the energy supply and the quality of the energy consumed.

As a result, a reasonable combination of consumed energy resources is provided based on the conditions for the use of renewable resources in the power supply system. All factors influencing the use of renewable energy sources must be taken into account in order to provide efficient energy to agricultural and water management.

In energy supply, depending on the power of consumers, the consumption of electricity from renewable sources ( $E_{RES}$ ) and traditional energy sources ( $E_{TE}$ ) is distinguished as follows:

$$E_C = \sum_{i=1}^n E_{RE} + E_{TE} \tag{8}$$

Part of the energy that the consumer lacks from renewable energy sources can be covered by traditional energy. In this case, the amount of energy consumed is equal to the share of energy exchanged for a traditional energy source, which is defined as follows:

$$k_i = \frac{E_{EL}}{E_C} \tag{9}$$

Appropriate studies are needed to assess the share of energy being replaced by renewable sources in the integrated power supply system. In this case, it is important to determine the mechanisms of operation of the systems and the integrated power supply system.

In a decentralized power supply system, small systems based on traditional sources are well known and studied. The characteristics of electricity and heat supply systems of agricultural and water economy consumers are known based on traditional sources. There

are new conditions for the design of these systems and other methods of modernization of existing power supply systems. In Uzbekistan, the power supply system based on renewable energy sources for agriculture and water management has not been sufficiently studied. At the same time, it may be necessary to develop appropriate technical solutions. The study of the operating conditions of the power supply subsystem is an important step in creating an efficient power supply system. The study of a subsystem that uses the energy of the solar and water energy is carried out according to certain principles.

### 3 Results and Discussion

The use of solar and water energy sources has shown that currently there are various technical solutions for the use of these types of energy [14]. Power generation devices may have the appropriate characteristics. At the same time, solar and hydropower devices are not structurally similar. The generation of electricity or thermal energy consists of individual elements. The efficiency of energy supply is determined by the development of technology for the use of renewable resources at the initial stage and the optimization of the installation parameters of energy production devices [15]. To develop the proposed power supply system, it is required to improve the methodology of the combined technical solution for the combined use of solar and water energy based on the adaptation of the dimensions of the parts to the system of agricultural and water management. What we are considering is the development of the electric power industry by combining solar and hydropower into a single power supply system based on renewable energy sources.

The system interacting with the external environment is open. The main sign of the openness of the system is its development, improvement, etc. Today, many scientific and technical problems of obtaining electrical and thermal energy from solar and water energy are solved at a high level [16]. A new power supply system can be created by determining the conditions for coordinating the developed renewable energy source and the modes of consumption of the consumed electricity (see Figure 4).

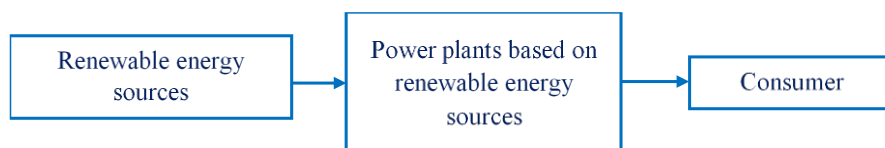
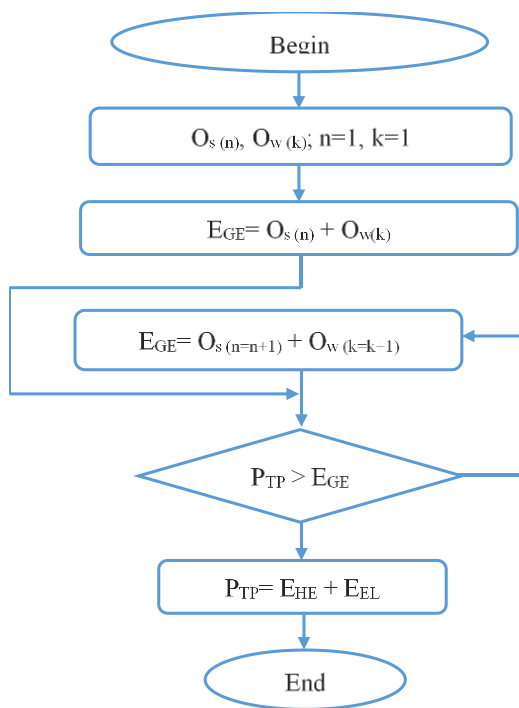

**Fig. 4.** Power supply system based on renewable energy sources

For a systematic analysis of the operating mode of the power source, a model of its operation and a functional diagram are developed that determine the stages that implement these processes, and the operating modes are mathematically modeled based on the feedback principle, which makes it possible to control energy sources (see Figure 5). Thus, it is necessary to create a working model of the RES system under study. We develop this model based on the following criteria:

- creation of a model of a technical solution for the use of solar energy and water in power supply;
- assessment of the energy efficiency of the integrated energy supply system;
- manage automated parameters in a single power supply system.

The operating model of the system under study is shown in Fig. 5. The result of the system operation is the useful energy of a renewable resource (SER) transferred to the technological facility.



**Fig. 5.** Operation model of electricity supply system based on renewable energy sources:  $O$  – energy from renewable energy: solar ( $O_s$ ) and water ( $O_w$ ) energy;  $E_{GE}$  – generated energy;  $P_{TP}$  – technological process capacity

To harmonize the regime under consideration, it is important to systematically study the operating conditions of the subsystem of renewable resources and ensure the integrated energy system as a whole. In the production and consumption of electricity, it is necessary to take into account the rapidly changing modes of operation of the agricultural and water management systems. To harmonize electricity generated from renewable energy sources with consumer operating modes, it is necessary to determine the main factors affecting the conditions for the use of solar and water energy in agriculture and water supply.

In order to match the electricity generated from renewable energy sources with consumer requirements, the following main parameters of electricity supply should be determined:

- characteristics of renewable resources;
- main parameters of power plants;
- consumed or accumulated energy.

The operation mode of the renewable resource subsystem can be studied based on the information about the characteristics of the incoming energy, the time pattern and the spatial structure of the renewable energy. During the research, mathematical models are developed to study renewable energy sources under certain conditions. When modeling the state of operation of the power supply subsystem from renewable energy sources, it is necessary to determine the energy characteristics of a renewable source. They should be convenient for studying the operating modes of other elements of the subsystem under study, in particular, for assessing the operation of the power plant, conditions for energy accumulation, etc.

The geophysical database is used to assess the energetic properties of solar and water energy and to determine the intensity and duration of the source. Electricity supply based

on renewable energy sources estimate based on the intensity and duration of the source and the modes of operation or idle time of the power plant.

When assessing the energy properties of a source, the following should be done [17]:

- daily, monthly and annual indicators of solar radiation according to long-term monitoring data;
- daily, monthly and annual indicators of the amount and speed of water flow;
- monthly, seasonal and annual duration or repeatability of solar radiation and water flow.

The above information allows a complete assessment of electricity generating. The value of calculate data in connection with the reproducibility regime in solving practical problems should not be overestimate. Probabilistic-statistical analysis of the studied quantities allows a preliminary assessment of the availability of renewable energy for a certain time (month, year).

When studying the energy characteristics of a renewable source, it is important to know the changes in time and area in advance. Information can be obtain on one or more energy source indicators in the selected area. The obtained information is necessary for analysis preliminary amount of electricity. For example, the speed or amount of water varies in different seasons or regions. It will be necessary to combine data for a certain area and summarize the characteristics of the energy indicator. An analysis of the aggregate energy indicators of sources determined by area makes it possible to determine the average quantities of variable energy sources. After the selection of the area, the potential renewable energy resources will evaluate. An important condition for this is to find the law of distribution of random variables, the choice of a mathematical model with a minimum number of parameters, the empirical distribution of the test characteristic in satisfactory certain physical and geographical conditions and within the required accuracy. Modeling the regime of geophysical processes makes it possible to determine the variability of the energy properties of solar radiation or water flow, the integral distribution function and the integral provision of the initial value [18]. It is necessary for further research to fully ensure the intensity of research characteristics, to evaluate the expected effect from the use of renewable resources. Thus, for a preliminary assessment of the indicators of the use of a renewable energy source, it is necessary to determine their energy parameters and simulate the operating modes of an object supplied with electricity based on the developed model. When coordinating the energy source with the consumer, it is important to determine the period of energy performance reduction for their use. Fluctuations of renewable energy over the day or year are natural. Sunlight has a maximum level at noon and decreases symmetrically with respect to it at other hours. Changes in water flow rate are also objective. More water flow is observed in the cold season.

A good option is to install a pumping station to pump water to farmland and gardens that are far from the power supply. However, laying central power lines to an installed pumping station can be very expensive. Therefore, it is preferable to create an autonomous system using solar panels, rather than pulling new power lines (see Figure 6).

Electricity generated by solar and hydropower can be used directly by connecting to a consumer, or can be stored. Thus, according to the consumed electricity, it is necessary to install a battery of the required capacity. When designing a power supply system, it is necessary to correctly select the power of the battery in a circuit developed on the basis of the use of renewable energy sources [19]. When designing the power supply system, the capacity of installed solar and hydroelectric power plants is determined based on the calculation of the load. Additional electric batteries can be connected to the designed system, which will ensure uninterrupted power supply in case of interruptions in the operation of a renewable energy source. The capacity of the electric battery depends on the period of collection and storage of electrical energy [20]. Today, several types of electric accumulators are used in practice. Electric batteries can vary in terms of service life and



storage of electrical energy. The most common are batteries that are used during the day and to store electricity for a short period of time.

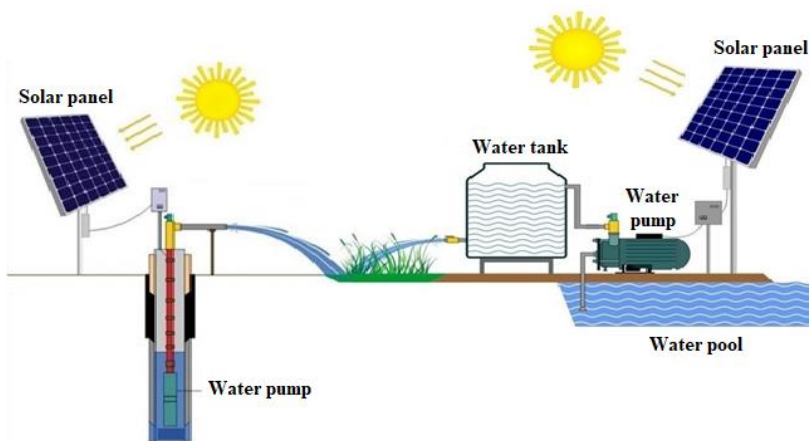

Fig. 6. Use of solar energy in the irrigation system

For the efficient use of renewable energy sources, the optimal dimensions of the necessary energy devices of solar and hydroelectric power plants consumed in a combined power supply system are determined. Solar batteries and hydro turbines are characterized by various technical indicators, the main of which is the efficiency of the solar collector and hydro turbine [21, 22, 23, 24]. The solar collector is characterized by the installation angle [25], and the hydro turbine is characterized by the speed of water movement [26]. These parameters should be taken into account when designing.

For the continuous supply of consumers with electricity from a decentralized power source, it is necessary to determine the following:

- capacity and number of solar panels for a solar power plant;
- the power and number of hydro turbines are required for a small hydroelectric power station.

As a result of the analysis of existing methods for designing solar and hydroelectric power plants, it is incorrect to calculate the power of a combined plant based on the area of solar panels or the installed power of a hydro turbine generator [27] In a power plant based on renewable energy sources, it is impossible to produce electricity at full capacity.

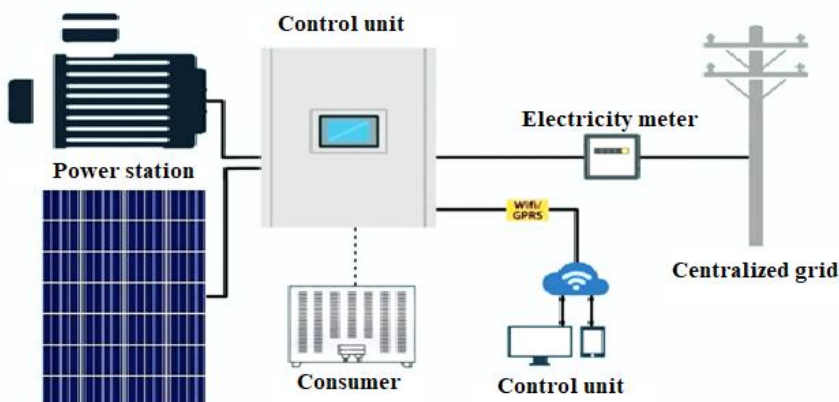

Fig. 7. The sequence of connecting the devices of the hybrid power plant

Installation of a hybrid solar and small hydro power plant at the designated site must be carried out based on the following requirements:

- All electrical devices, circuit breakers and fuses, electrical equipment that protect against short circuits must be protected by a grounding device;
- solar panels, the generator and its terminals, as well as the electric cable must be located in a place inaccessible to water;
- When using a hybrid powertrain, the technical safety instructions must be observed.

When preparing a hybrid device of a solar and small hydroelectric power plant for testing, the following sequence should be observed:

- solar panels, hydro generator, control unit, meter, control unit, centralized power grid and consumers are connected in sequence, as shown in Figure 7;
- solar panels and a hydro generator are connected to the electric cable control unit.

The quality indicators of electricity generated by solar and hydroelectric power plants were checked by an electrical measuring instrument-analyzer Circutor AR.6. In the course of research, great importance is attached to 2 parameters that mainly determine the quality indicators of electricity: voltage (V) and frequency (Hz). The results obtained are compared with the limits of values specified in the normative documents of the international standard. An energy audit to assess the quality of electricity is performed using the Circutor AR.6 electrical analyzer in the following order:

- We start the AP.6 electrical analyzer and connect its flash according to the scheme;
- enter the required dimensions into the measuring device. This includes the measurement time intervals, the limit values of voltage, current and the processes of their recording in memory;
- we check that all the data obtained after carrying out the measurement work on the measuring device in the specified time interval are recorded in its memory;
- after making sure that all the data is recorded in the memory of the measuring device, turn it off and disconnect the device from the network;
- to process the received data, we connect the device to a computer and process all measurement data using the Power Vision program.

Our first research was conducted on March 21, 2021 from 15:10 to 15:20. In this case, all checks were carried out simultaneously. An analysis of the data obtained from the voltage deviation and frequency change tests is shown in Figure 8.

In the diagram above, the maximum voltage is 207 volts, the minimum voltage is 202 volts, and the average voltage is 205 volts. This is “according to the international standard regulatory document, the AC voltage limit is  $\pm 10\%$  (198–242 Volts)”. The voltage of 205 volts, determined in the course of research, fully meets the requirements of consumers in agriculture and water management. The value of the frequency change obtained as a result of the test experiment was equal to 50 Hz and did not change. This figure is also equal to the frequency of the AC voltage of 50 Hz according to the international standard regulatory indicators. Thus, based on the results of scientific research, it was found that the quality indicators of electricity generated in the developed solar-hydrohybrid power plant fully comply with the requirements of the regulatory document of the international standard.

In the general case, unified power supply combines centralized and decentralized power supply on the basis of one system. All power plants connected to the same system may have different capacities or outputs, but must be based on the same requirements when connecting to a consumer. It is important to minimize the necessary costs when providing consumers with energy of the studied complex power supply system. Efficient use of non-traditional energy resources minimizes the cost of energy. Therefore, one of the main steps in the development of decentralized power supply is to determine a reasonable combination of traditional and non-traditional energy resources.

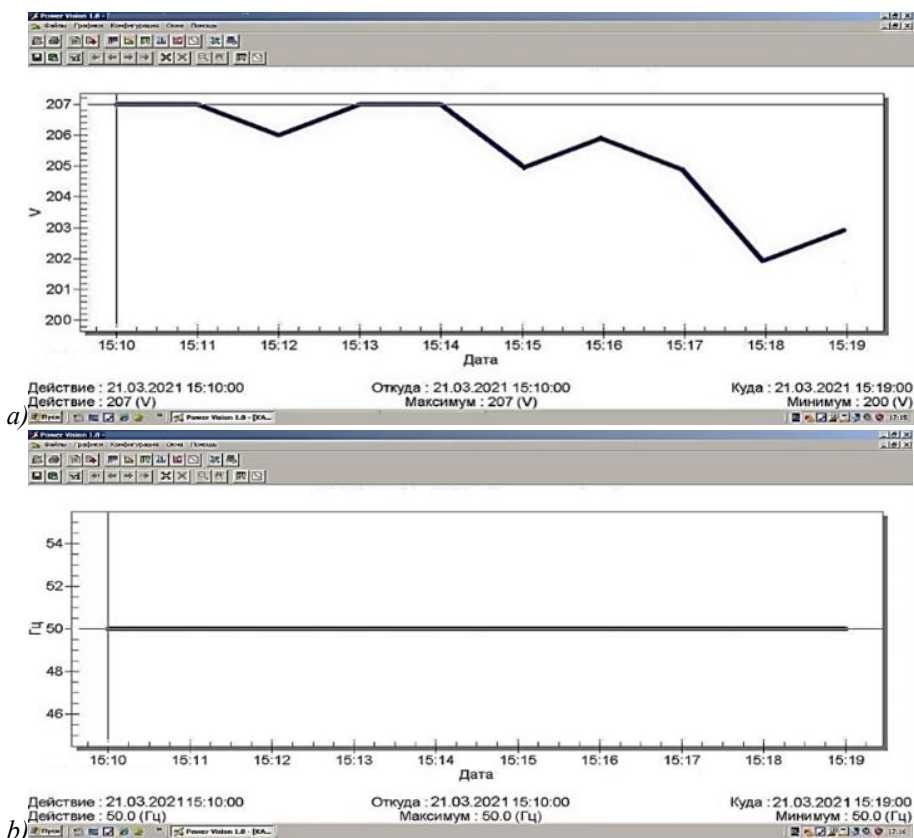

Fig. 8. Change in voltage (a) and frequency (b) between 15:10 and 15:20

## 4 Conclusions

Summarizing the research results related to this work, we can draw the following conclusions:

- A four-stage research model was selected for the joint use of centralized and decentralized electricity supply for agricultural and water economy consumers. The use of a four-stage research model allows choosing the optimal combination of energy resources for a consumer working in different operating modes.
- Creates an integrated power supply system based on the combined use of traditional and renewable energy sources. The integration of the system is represented by the selection of the right combination of resources.
- Conditions have been developed to provide consumers of agriculture and water management in an integrated power supply system from renewable energy sources. It is determined that the continuity of power supply depends on the conditions for the joint use of centralized and decentralized power supply.
- The conditions for the simultaneous use of solar and water energy are determined, depending on the conditions for the continuous supply of consumers with the daily necessary electricity. In this case, the efficiency of the power supply system is characterized by the percentage of energy replaced by traditional energy (kW·h). To estimate the share of exchange energy, an analytical expression is obtained that takes into account the characteristics of the incoming and outgoing energy.

## References

1. A. Anarbaev, O. Tursunov, R. Zakhidov, D. Kodirov, A. Rakhmatov, N. Toshpulatov, S. Namozov, E. Sabirov, Calculation the dynamic stability zone of the distribution grid with generating sources based on renewable energy, *IOP Conference Series: Earth and Environmental Science* **614**(1), 012004 (2020)
2. D. Kodirov, K. Muratov, O. Tursunov, E.I. Ugwu, A. Durmanov, The use of renewable energy sources in integrated energy supply systems for agriculture, *IOP Conference Series: Earth and Environmental Science* **614**(1), 012007(2020)
3. A. Anarbaev, A. Muxammadiev, S. Umarov, O. Tursunov, D. Kodirov, S. Khushiev, F. Muhtarov, S. Muzafarov, J. Izzatillaev, Mobile installations for electro treatment of soils and plants with the use of photovoltaic systems as power supply, *IOP Conference Series: Earth and Environmental Science* **614**(1), 012046 (2020)
4. A. Mirzabaev, A.J. Isakov, S. Mirzabekov, T. Makhkamov, D. Kodirov, Problems of integration of the photovoltaic power stations with the grid systems, *IOP Conference Series: Earth and Environmental Science* **614**(1), 012016 (2020)
5. W. Strielkowski, L. Civin, E. Tarkhanova, M. Tvaronavičienė, Y. Petrenko, Renewable Energy in the Sustainable Development of Electrical Power Sector: A Review, *Energies* **14**(24), 8240 (2021)
6. A. Isakov, A. Mirzabaev, O. Sitdikov, M. Makhkamova, D. Kodirov, Innovative methods of developing solar power systems for remote and agricultural facilities in Uzbekistan, *IOP Conference Series: Earth and Environmental Science* **614**(1), 012014 (2020)
7. Ch Kaushik, Renewable energy for sustainable agriculture, *Agronomy for Sustainable Development* **31**(1), 91-118 (2011)
8. L. Gan et al. Balancing of supply and demand of renewable energy power system: A review and bibliometric analysis, *Sustainable Futures* **2**, 100013 (2020)
9. D. Kodirov, O. Tursunov, A. Ahmedov, R. Khakimov, M. Rakhmataliyev, Economic efficiency in the use of solar energy: A case study of Agriculture in Uzbekistan, *IOP Conference Series: Earth and Environmental Science* **614**(1), 012031 (2020)
10. D. Kodirov, O. Tursunov, K. Karimova, N. Akramova, S. Parpieva, B. Shafkarov, Application of hydro energy in small power supply systems, *IOP Conference Series: Earth and Environmental Science* **614**(1), 012037 (2020)
11. Z. Yusupov, N. Almagrahi, O. Tursunov, D. Kodirov, H.A. Almgarbj, N. Toshpulatov, Fault control of microgrid system: A case study of Karabuk University-Turkey, *IOP Conference Series: Earth and Environmental Science* **614**(1), 012019 (2020)
12. D. Kodirov, O. Tursunov, S. Khushiev, O. Bozarov, G. Tashkhodjaeva, S. Mirzaev, Mathematical description of water flow quantity for microhydroelectric station, *IOP Conference Series: Earth and Environmental Science* **614**(1), 012032 (2020)
13. A. Davirov, O. Tursunov, D. Kodirov, B. Rakhmankulova, S. Khodjimukhamedova, R. Choriev, D. Baratov, A. Tursunov, Criteria for the existence of established modes of power systems, *IOP Conference Series: Earth and Environmental Science* **614**(1), 012039 (2020)
14. D. Kodirov, O. Tursunov, D. Talipova, G. Shadmanova, S. Parpieva, B. Shafkarov, System approach to renewable energy use in power supply, *IOP Conference Series: Earth and Environmental Science* **614**(1), 012038 (2020)
15. A.N. Abdalla et al., Integration of energy storage system and renewable energy sources based on artificial intelligence: An overview, *Journal of Energy Storage* **40**, 102811 (2020)
16. S. Tabassum, T. Rahman, A.U. Islam, S. Rahman, D.R. Dipta, S. Roy, N. Mohammad, N. Nawar, E. Hossain, Solar Energy in the United States: Development, Challenges and Future Prospects, *Energies* **14**(23), 8142 (2021)
17. N.N. Sadullaev, A.B. Safarov, R.A. Mamedov, D. Kodirov, Assessment of wind and hydropower potential of Bukhara region, *IOP Conference Series: Earth and Environmental Science* **614**(1), 012036 (2020)
18. M.R. Tye et al., Assessing Evidence for Weather Regimes Governing Solar Power Generation in Kuwait, *Energies* **12**, 4409 (2019)
19. A. Mirzabaev, S. Mirzabekov, T. Makhkamov, O. Soliev, O. Sitdikov, D. Kodirov, The impact of renewable energy sources on power flows in the electric power system of Uzbekistan, *AIP Conference Proceedings* **2686**, 020011 (2022)

20. A. Safarov, H. Davlonov, R. Mamedov, M. Chariyeva, D. Kodirov, Design and modeling of dynamic modes of low speed electric generators for electric power generation from renewable energy sources, *AIP Conference Proceedings* **2686**, 020013 (2022)
21. S.A. Kalogirou et al., Exergy analysis on solar thermal systems: A better understanding of their sustainability, *Renewable Energy* **85**, 1328-1333 (2016)
22. M. Zukowski, M. Kosior-Kazberuk, T. Blaszczynski, Energy and Environmental Performance of Solar Thermal Collectors and PV Panel System in Renovated Historical Building, *Energies* **14**(21), 7158 (2021)
23. J. Allan, Z. Dehouche, S. Stankovic, L. Mauricette, Performance testing of thermal and photovoltaic thermal solar collectors, *Energy Science and Engineering* **3**(4), 310-326 (2015)
24. K. Isakhodjayev, F. Mukhtarov, D. Kodirov, I. Toshpulatov, Development of a laboratory nozzle chamber installation for the humidification of buildings, *IOP Conference Series: Earth and Environmental Science* **939** (1), 012025 (2021)
25. E.A. Handoyo, D. Ichسانی, Prabowo, The Optimal Tilt Angle of a Solar Collector, *Energy Procedia* **32**, 166-175 (2013)
26. E. Quaranta, M. Bonjean, D. Cuvato, C. Nicolet, M. Dreyer, A. Gaspoz, S. Rey-Mermet, B. Boulicaut, L. Pratalata, M. Pinelli, G. Tomaselli, P. Pinamonti, R. Pichler, P. Turin, D. Turrin, J. Foust, B. Trumbo, M. Ahmann, M. Modersitzki, S. Kist, C. Mosca, C. Malerba, A. Francesconi, I. Casoli, R. Ferrari, V. Stefani, M. Scibetta, L. Meucci, W. Gostner, R. Bergamin, F.D. Pretto, D. Turcato, V. Kocher, P. Lefauchaux, A. Elmaataoui, M. Mariucci, P. Sarma, G. Slachmuylders, R. Clementi, F. Pasut, N. Bragato, Hydropower Case Study Collection: Innovative Low Head and Ecologically Improved Turbines, Hydropower in Existing Infrastructures, Hydropeaking Reduction, Digitalization and Governing Systems, *Sustainability* **12**(21), 8873 (2020)
27. A. Mirzabaev, A. Isakov, O. Soliev, M. Makhkamova, D. Kodirov, Major trends characterizing solar energy development in Uzbekistan, *IOP Conference Series: Earth and Environmental Science* **939**(1), 012010 (2021)