

Influence of degree of saturation on the dynamic soil properties of a sandy soil

Rafael Baltodano-Goulding^{1,2*}, and Laura Brenes-Garcia¹

¹LabUnsat, Civil Engineering Department, University of Costa Rica, San Jose, Costa Rica

²Construction Engineering, Costa Rica Institute of Technology, Cartago, Costa Rica

Abstract. It is commonly assumed that the fully-saturated scenario represents the critical shear strength condition for geotechnical structure design; nevertheless, this is not the case when the dynamic shear strength of unsaturated soil is considered, because the water content affects the transfer of seismic waves through the porous medium and into a structure. It is important to better understand this behavior so the soil response during an earthquake could be established to prevent damage or failure of the structure. A series of cyclic triaxial tests with controlled matric suction was conducted to determine the principal dynamic parameters for a sandy soil for different degrees of saturation. Finally, to assess the influence of soil saturation on the dynamic soil properties of a sandy soil, a dynamic lateral load pile design was performed using Reese's p-y curve method, and the parameter obtained from the laboratory testing were used to back-calculate the seismic coefficients used for structural design. Structural designs of laterally loaded piles considering different soil degrees of saturation demonstrated that the saturated soil condition while subjected to a dynamic condition does not represent the critical load case for seismic analysis.

1 Introduction

In conventional soil mechanics, it is commonly assumed that the critical condition design for any load type is associated with fully-saturated soil. Nevertheless, in a seismic condition, a dynamic load is transferred from the soil to the structure, and because the velocity wave propagation (V) in any medium is dependent on its stiffness, represented by the secant modulus (G), and density (ρ), as presented in Equation 1, it can be argued that the critical condition for design must consider unsaturated soil conditions.

$$G = \rho V^2 \quad (1)$$

When the foundations are embedded in the soil, it is necessary to consider that the soil's stiffness is dependent on its water content, therefore, the degree of saturation changes affects how the seismic load is transferred to the structure. Consequently, the dynamic load considered in the structure's design not only depends on the seismic load, but also, on the soil dynamic properties, which change with water content, hence they must be considered in the structural foundation design, and the structural dynamic behavior.

The design of foundations traditionally considers the transfer of loads from the structure into the ground and considers the applied loads and the bearing capacity of the soil. Nevertheless, the soil's dynamic behavior and foundation response must be accounted for in the design process to guarantee the structure's safety. However, because the soil shear strength and strain behavior are directly influenced by its effective stress, and the effective stress is affected by the soil's water

content to be able to mitigate or prevent structure damages during an earthquake, it is important to account for the unsaturated condition.

For this research, dynamic lateral load pile design was considered to compare the obtained results. Reese's p-y curve method [1] is widely used, but it assumes a fully saturated or completely dry soil, and no parameters considering unsaturated conditions are generally used in practice.

Previous research related to this topic of lateral loading of pile foundations, such as Mokwa et al. [2], where p-y curves in unsaturated silts and clays have been presented. Also, Gonzalez [3] compared design methodologies, like Matlock & Reese, and Winkler, with Finite Element Modeling, showing these methodologies are not reliable for final designs. Additionally, Suprunenko [4] studied the influence of soil suction on the dynamic shear modulus of unsaturated sands.

This research aims to estimate the effect of structural pile design due to changes in saturation and to assess the limitations of current practices.

2 Material Characterization

A sandy soil with a uniform particle size was used to conduct this research. The results from its geotechnical characterization are presented in Table 1. It is worth mentioning that the authors have also used fine-grained material in previous research [5]

* Corresponding author: rafael.baltodanogoulding@ucr.ac.cr

Table 1. Soil specimen characterization.

Laboratory test	Index property	Value
Specific gravity	Specific gravity	2.70
Grain size distribution	Percentage passing sieve #10	100%
	Percentage passing sieve #40	66%
	Percentage passing sieve #200	0%
	Coefficient of Uniformity	1.455
	Coefficient of curvature	0.874
Soil classification system	USCS	SP (poorly graded sand)
	AASHTO	A-3(0) (fine sand)

3 Methodology

A dynamic lateral load pile design was executed using Reese’s p-y curve method to assess the influence of soil degree of saturation in the transfer of a dynamic load to a deep foundation. This design method considers the soil stiffness through the relative stiffness factor (T), which can be calculated with Equation 2.

$$T = \left(\frac{EI}{n_h} \right)^{1/5} \quad (2)$$

Where E is Young’s modulus, I the moment of inertia of the pile’s material, and n_h the soil’s Modulus of Subgrade Coefficient, which is defined as the ratio between the soil’s Modulus of Subgrade Reaction (E_s) and the depth (z) at which the parameter is being calculated, as presented in Equation 3.

$$n_h = \frac{E_s}{z} \quad (3)$$

E_s can be obtained from the ratio between a lateral load (p) and its corresponding deformation (y), as shown in Equation 4. In Reese’s method, this value is assumed constant.

$$E_s = \frac{p}{y} \quad (4)$$

Equation 4 represents the theory of the subgrade reaction, based on the p-y curve, which establishes that lateral loads can be replaced by springs at different pile locations [1]. This theory considers a non-linear elasticity of soil, because of the anisotropy behavior of any type of soil, which will have a different response varying its depth, and thus different p-y curves. For simplicity of the calculations presented, the value of the Modulus of the Subgrade Reaction was considered constant at any depth.

The experimental Moduli of subgrade reaction was determined at different degrees of saturation (including the saturated condition), and they were used in the lateral pile capacity analysis. Likewise, Reese’s methodology was used with a theoretical Modulus of subgrade reaction to compare the results with the ones obtained using experimental information. Then, the seismic coefficient applied in structural design was back-calculated and compared to assess how the water content variation affects the final pile structural design, in terms of dimension and steel quantity. The theoretical Moduli of subgrade reaction considered in the design were obtained from the Manual of pile design and construction by the Federal Highway Administration (FHWA) of the U.S. Transportation Department [6], presented in Table 2.

Table 2. Representative Moduli of Subgrade Reaction Values for Sand [6].

Soil type	Soil condition at water table	Modulus of Subgrade Reaction (pci)
Loose sand	Submerged	20
	Above	25
Medium dense sand	Submerged	60
	Above	90
Dense sand	Submerged	125
	Above	225

The seismic coefficient was obtained from Costa Rica’s Seismic Code (2014) [7], whose selection is based on historical seismic behavior and soil type but assumes a fully-saturated material. The pseudo-static method is applied for the calculation of the dynamic load (P), and it relates the structure weight (W) with the seismic coefficient (C) to determine the basal shear force, as shown in Equation 5.

$$C = \frac{P}{W} \quad (5)$$

Additionally, the lateral load associated with the experimental Moduli of Subgrade Reaction was calculated using Equation 6, considering the maximum lateral deformation (δ_{max}) obtained from the pile design analyses executed with the theoretical parameters of soil stiffness.

$$P = \frac{\delta_{max}EI}{T^3 A_\delta} \quad (6)$$

Where A_δ equals 2.435 because is the depth in which the maximum lateral deformation occurs. Is important to mention that the calculated lateral loads represent the seismic force that is transferred from the foundation to the structure.

To determine the dynamic soil properties under different degrees of saturation, a suction-controlled cyclic triaxial test was performed on each specimen, using the same failure criterion for the dynamic loading for all specimens so results can be compared. The

equipment used for this research (shown in Fig. 1) is from GCTS (Geotechnical Consulting & Testing Systems), which permits testing soil specimens controlling matric suction, and has the capability to perform triaxial and resilient modulus tests.



Fig. 1. Apparatus for suction-controlled cyclic triaxial tests.

The equipment software (GCTS CATS) allows for a constant cyclic load to be programmed, introducing the values of frequency, number of cycles, amplitude, and maximum percentage of deformation. The failure criterion used is presented in Table 3. Any condition and restriction established in the norm ASTM D-5311 was considered during the tests that were performed. The net normal stresses used were 50 kPa, 100 kPa, and 500 kPa.

Table 3. Failure criterion for suction-controlled cyclic triaxial tests [8].

Cyclic load value	Failure criterion
Frequency	1 Hz
Maximum number of cycles	500 cycles
Amplitude (peak to peak)	270 kPa
Maximum percentage of deformation	3%

Three soil specimens were tested; their characteristics are shown in Table 4. These specimens were tested with the same relative density of 15% to represent a loose condition. Due to the type of material, the specimens were molded, using the subcompaction method [9], with the moisture content associated with the matric suction value that was applied during the cyclic triaxial test.

Table 4. Specimen's densities and moisture characteristics.

Specimen	Total unit weight (g/cm ³)	Molding moisture
1	1.600	3%
2	1.698	9%
3	1.636	5%

Using the Soil-Water Characteristic Curve (SWCC), which was determined using the van Genuchten model and taking suction measurements with the filter paper method ASTM D5298 [10] procedure, values of matric suction of 212 kPa and 435 kPa were selected. The SWCC of this material is presented in Fig. 2. This curve exhibits just a few data due to laboratory limitations.

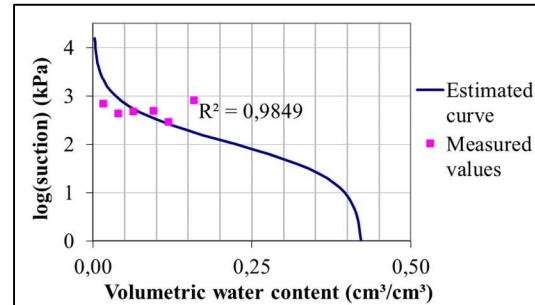

Fig. 2. SWCC of the sandy soil.

Applying Equation 4 in the axial hysteretic cycle, calculating the slope between the origin of the hysteretic cycle and its amplitude the soil's dynamic parameters at different degrees of saturation were determined, as can be seen in Fig. 3. Due to the number of cycles tested in each specimen, only 3 cycles from the saturated specimen and 4 cycles from the unsaturated ones were chosen.

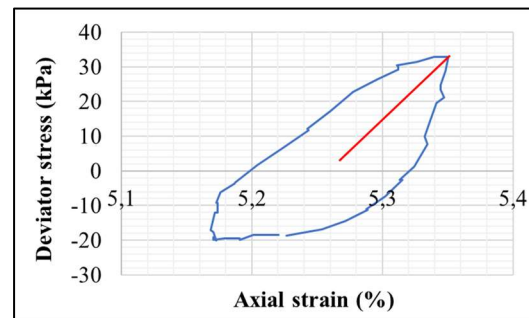

Fig. 3. Secant Modulus from Load Cycle #100 of the specimen with suction of 212 kPa.

Once this data was available, the procedure indicated in this section was applied to obtain the geotechnical and structural pile design for each case. Then, the effect of the degree of saturation in the transfer of seismic loads was evaluated in a similar manner as Brenes [8] did for fine-grained soil. Although it is expected that unsaturated soil stiffness increases with higher suction, measured laboratory testing is needed to use actual values for the structural pile design.

4 Results and Analysis

For this section, first, the dynamic soil parameters are presented, and then the analysis executed for the pile design is shown. In that way, it is possible to evaluate the influence of the degree of saturation in both the dynamic parameters and the seismic load transfer.

4.1 Dynamic soil parameters

The principal dynamic soil parameters are calculated by the triaxial software GCTS CATS for each loading cycle for each specimen, considering a secant line in the hysteretic cycle amplitude that extends from peak to peak. To compare the influence of the degree of saturation in the dynamic soil parameters, Fig. 4, Fig. 5, and Fig. 6 are presented as a comparison of the cyclic Young's modulus, cyclic shear modulus, and hysteretic damping, respectively, for the three specimens tested, during the cyclic loading.

It was observed that the trend is not the same between specimens with different suction values, especially the one with 212 kPa suction, because, at some point, the cyclic moduli increase until it reaches a maximum value, and then it decreases. One possible explanation is that this behavior is associated with the loose condition of the specimen. The other two specimens show the expected trends of decreasing the cyclic modulus as the number of cycles of loading increases. Nevertheless, it still can be appreciated that the specimen with a higher suction value has a higher cyclic modulus.

Regarding the hysteretic damping, the expected trend is not obtained either, because the specimen with 212 kPa suction value has higher damping than the one with 435 kPa, when it was anticipated that the specimen with higher suction should exhibit lower hysteretic damping. In addition, theoretically, is anticipated that the hysteretic damping value remains constant, independently of the number of cycles applied to the specimen. The specimen with 212 kPa suction value does not reflect this conduct because as cycle loading increases, its value decreases. The other two specimens display a constant trend.

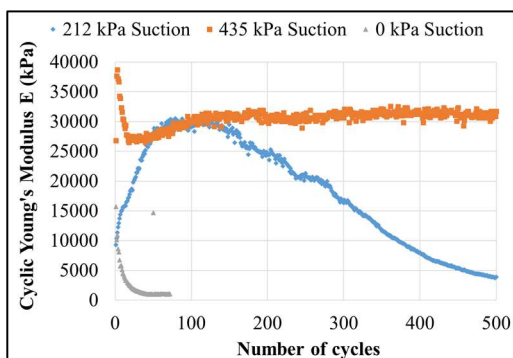

Fig. 4. Cyclic Young's modulus behavior during cyclic loading.

4.2 Dynamic lateral load pile design

First, a lateral load pile design was performed, considering theoretical stiffness parameters, and calculating the force using the pseudo-static method established in Costa Rica's Seismic Code [7]. Table 5 shows the calculated values of the dynamic lateral load pile design for this case, using Reese's p-y curve method. For the seismic coefficient, according to Costa Rica's Seismic Code, an S3 soil, a global ductility

of 1, and a dynamic spectral factor of 2.5 was considered. Also, for the theoretical soil's modulus of subgrade coefficient, a value associated with submerged loose soil was used. With this information, a maximum lateral deformation value of 5.74 cm was obtained with a 65 cm pile diameter.

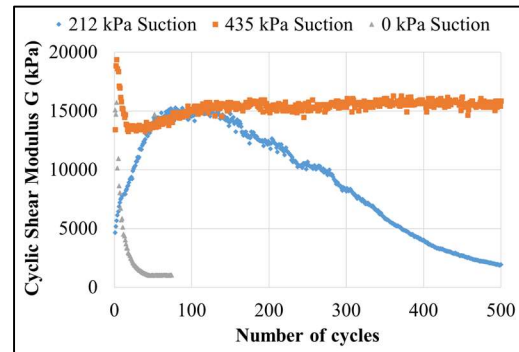

Fig. 5. Cyclic shear modulus behavior during cyclic loading.

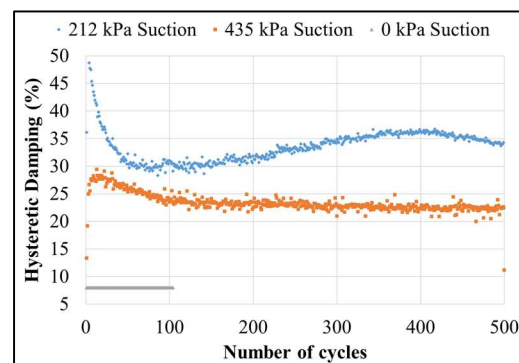

Fig. 6. Hysteretic damping behavior during cyclic loading.

Table 5. Dynamic lateral load pile design considering theoretical parameters.

Parameter	Value
Seismic coefficient C	0.75
Structure weight (tonne)	82.85
Lateral load (tonne)	62.00
Pile diameter (cm)	65.00
Pile length (m)	15.00
Soil's Modulus of Subgrade Coefficient n_h (tonne/m ³)	576.00
Relative stiffness factor T (m)	2.15
Maximum lateral deformation δ_{max} (cm)	5.74
Maximum moment M_{max} (tonne-m)	103.06
Maximum shear force V_{max} (tonne)	62.00

Having the theoretical information, it is possible to back-calculate a seismic coefficient associated to an experimental modulus subgrade coefficient. A comparison of the experimental modulus subgrade coefficient behavior during the selected load cycles between specimens was graphically obtained (Fig. 7). As expected, specimens with a higher matric suction increase the modulus of subgrade coefficient because of the increment in soil stiffness, regardless of the cycle number considered. Likewise, a decrease of the modulus of subgrade coefficient occurs as the number of cycles increases, except for the specimen with 435 kPa matric suction. This behavior can be attributed to the loss of soil stiffness because of the repetition of cycle loading. Because the seismic coefficient depends on the modulus subgrade coefficient, as shown in Equation 2 to 6, the specimens have the same behavior and overall trends.

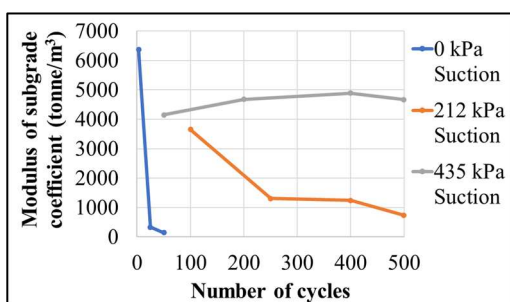

Fig. 7. Subgrade modulus coefficient as a function of the load cycles.

Fig. 8 displays the experimental subgrade modulus coefficient as a function of the seismic coefficient back-calculated from the experimental results of the three specimens tested. The yellow dot represents the theoretical seismic coefficient used in the theoretical pile design. An increasing trend of the seismic load is observed as the subgrade modulus coefficient increments, suggesting that these parameters are related. Consequently, the stiffer the soil the greater the seismic load that is transferred throughout the ground soil and into the foundation. Also, the greater the matric suction, the greater the seismic coefficient. Because the matric suction is related to the soil's degree of saturation, and it directly affects its effective stress, then is possible to conclude that the soil's effective stress has an influence on the transfer of seismic loads.

Another aspect that can be observed in Fig. 8 is that, if soil undergoes various load cycles, then its stiffness reduces, suggesting that the seismic coefficient will also decrease. Also, the theoretical saturated seismic coefficient (yellow dot) does not predict the maximum seismic force transferred from the soil to the structure because the degree of saturation not only influences the soil shear strength, but also the soil-structure interaction and the structure's acceleration produced by the seismic wave. This statement means that the value of the seismic load depends on the soil water content.

As an example two structural pile designs were performed: one considering the theoretical Reese's method (shown in Fig. 9), established by the FHWA (Table 2), and the other one considering the experimental values that were obtained with the suction-

controlled cyclic triaxial tests, specifically, the 435 kPa matric suction specimen (Fig. 10). It is noteworthy to consider further investigation to be executed to consider the impact of the assumptions of the seismic coefficients and theoretical values of soil and theoretical values of soil stiffness made, in the results to analyze properly the influence of soil stiffness in the dynamic lateral load pile design.

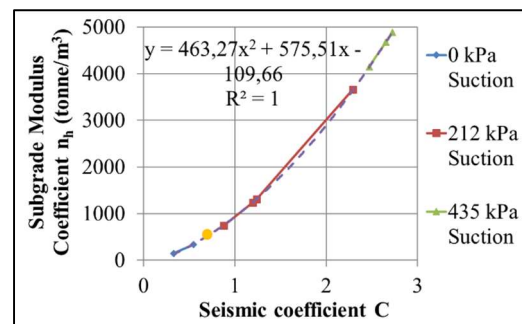

Fig. 8. Subgrade Modulus Coefficient as a function of the seismic coefficient.

From the designs shown, it can be observed that the pile design with experimental parameters has a larger diameter and more amount of steel than the one with theoretical parameters. This behavior is due to the increment of the seismic coefficient in the unsaturated specimens, therefore, the transferred lateral load increases producing a moment that requires a larger diameter than the minimum obtained from the saturated condition. Hence, the fully-saturated soil does not represent the critical load case for seismic analysis in the dynamic lateral load pile design.

Conclusions

The dynamic soil parameters of a sandy soil are highly influenced by its degree of saturation. Soil specimens with higher matric suction values tend to have higher soil stiffness, implying greater cyclic Young's and shear moduli. On the other hand, as load cycles are applied, the cyclic moduli tend to decrease because of the increment of soil rigidity as a consequence of load repetition. With respect to the hysteretic damping, it was expected that the soil with higher water content will have higher damping. Also, the hysteretic damping is supposed to be constant during cyclic loading. Nevertheless, this trend was not observed for the tested specimens.

It is possible to obtain experimental subgrade moduli coefficients performing cyclic triaxial test. The elastic secant modulus of the axial hysteretic cycle obtained from this test is equal to the soil modulus, which represents the slope of the p-y curves. If Reese's method is applied to a lateral load pile design, then the soil subgrade modulus coefficient is equal to the soil modulus times the pile length. A unit value of pile length was considered so the value of the soil subgrade modulus coefficient can be applied to different piles.

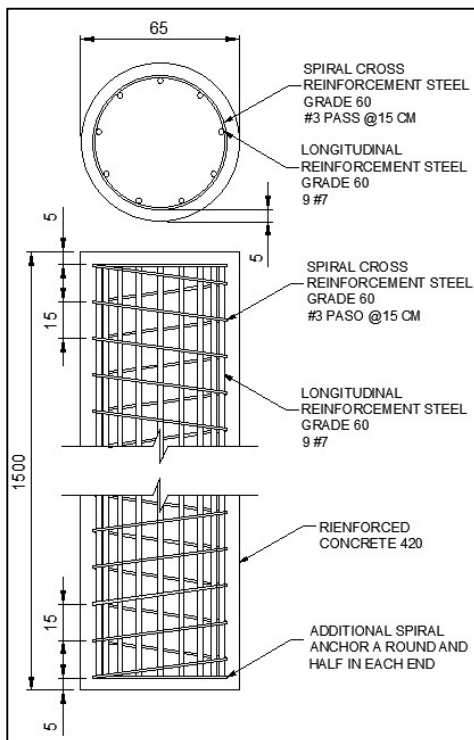

Fig. 9. Theoretical parameters pile design.

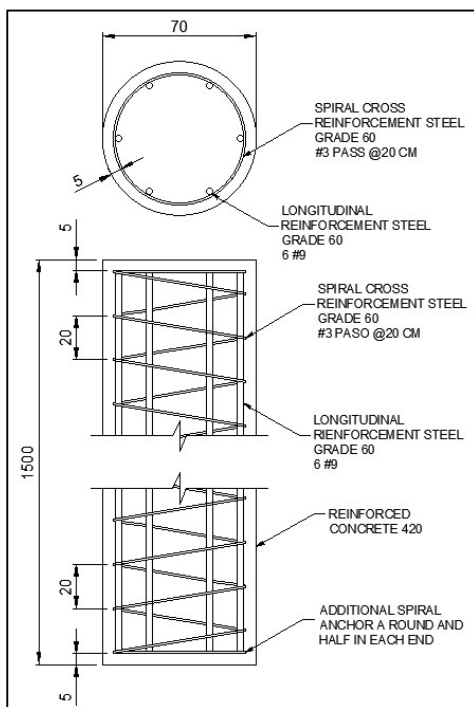

Fig. 10. Experimental parameters pile design (435 kPa matrix suction specimen).

The results suggest that there is enough evidence to conduct further investigations on the influence of the degree of saturation in sandy soils on the transfer of seismic loads from the soil to the structure. The greater the matrix suction, the greater the seismic coefficient, so the saturated seismic coefficient considers a lower value of the dynamic load.

The pile designs demonstrated that the critical condition for a dynamic lateral load pile cannot necessarily be represented by a fully-saturated soil. The

piles with higher structural requirements under seismic loading are associated with unsaturated soil conditions. This behavior can be attributed to the amplification of seismic waves when soil stiffness increases (higher stress transfer efficiency), thus, producing an increase in the transfer of the seismic load.

The higher the suction values the smaller the damping (Fig. 6) This can be attributed to a higher stress transfer efficiency in stiffer materials. In this research, the saturated condition damping was using a conventional calibration curve, while the unsaturated condition damping was directly measured from laboratory testing.

References

1. B.J. Meyer & L.C. Reese. *Analysis of Single Piles Under Lateral Load*. (1979).
2. R.L. Mokwa, J.M. Duncan, and M.J. Helmers. *Development of p-y Curves for Partly Saturated Silts and Clays*. (2000).
3. J. Gonzalez. *Analisis comparativo de la respuesta de puentes integrales con pilotes sometidos a carga lateral* (Graduation Project, University of Costa Rica, 2012).
4. G. Suprunenko. *Suction-Controlled Cyclic Triaxial Test to Measure Strain-Dependent Dynamic Shear Modulus of Unsaturated Sand*. (2015)
5. R. Baltodano-Goulding & L. Brenes-Garcia. *Influence of Degree of Saturation on the Dynamic Soil Properties of a Fine-grained Soil*. (2022).
6. Federal Highway Administration (FHWA) of the U.S Department of Transportation. *Design and Construction of Driven Pile Foundations*. (GEC. No. 12. 1, 2016).
7. Costa Rica's Board of Professional Engineers and Architects (CFIA). *Seismic Code of Costa Rica 2010* (2014).
8. L. Brenes. *Evaluación del método de Reese y Matlock para el diseño de un pilote con carga lateral dinámica en un limo de relativa baja plasticidad a diferentes saturaciones* (Graduation Project, University of Costa Rica, 2020).
9. R. Baltodano-Goulding. *Tensile Strength, Shear Strength, and Effective Stress for Unsaturated Sand* (Dissertation, University of Missouri, Columbia, 2006).
10. ASTM. *Standard Test Method for Measurement of Soil Potential (Suction) Using Filter Paper* (2010).