

# On the functioning of capacitor banks in smart grids

Lidiia Kovernikova<sup>1\*</sup>

<sup>1</sup>Melentiev Energy Systems Institute, Power Systems Department, 664033, Lermontov Str., Irkutsk, Russian Federation

**Abstract.** The amount of electronic equipment is increasing in created smart grids. This equipment introduces distortions into the electrical network, due to which the voltages at the network nodes, and hence the currents, become nonsinusoidal. The paper is devoted to the analysis of the effect of capacitor banks on the electrical network with nonsinusoidal mode parameters due to the resonant circuits they create with the electrical network at harmonic frequencies, as well as the influence of nonsinusoidal network modes on capacitor banks. The paper presents an overview of scientific publications on the problem of harmonic resonances in nonsinusoidal network modes, as well as the values of power quality indices that were measured in the study of the effect of the capacitor bank on the network mode. With the help of the “Harmonics” software package, the reduction in the service life of the capacitor bank in the nonsinusoidal mode, the frequency characteristics of admittance, conductance, susceptance of the network node with the capacitor bank, and the resonant powers of the capacitor bank at harmonic frequencies were calculated.

## 1 Introduction

Smart grids are created in Russia. They have distributed generation as well. Electronic equipment ensures the functioning of smart grids. It is the reason for the deterioration of the power quality in smart grids. The power quality in them does not meet the requirements of GOST 32144-2013 [1]. The results of measurements of the power quality indices confirm this fact [2]. Electronic equipment has non-linear current-voltage characteristics, and it consumes nonsinusoidal current from the supply network. The nonsinusoidal current flows in the electrical network and creates nonsinusoidal voltage drops on the network elements. The voltages at the network nodes become nonsinusoidal. A distorted voltage supplies the linear loads. Nonsinusoidal currents and voltages contain sinusoidal components of the fundamental frequency, i.e. with the frequency corresponding to the period of the original waveform or the first harmonic number ( $n=1$ ), and frequencies that are multiples and non-multiples of the fundamental frequency with harmonic numbers higher than the first ( $n>1$ ). The active power transmitted through the electrical network contains the active power of the first harmonic and the active power of the harmonic numbers  $n>1$  [3, 4]. The active power of the first harmonic is useful because it does useful work. Active powers with harmonic numbers  $n>1$  are harmful, since they do not perform useful work. The time of rapid development of industrial technologies using electronic equipment was already in the last three decades of the twentieth century. The power quality has deteriorated sharply due to the harmonics of currents, voltages, and powers. They caused additional power losses in electrical networks, false alarms of

control systems, reduced service life of electrical equipment, resonant overvoltages and other consequences [5-19].

The present paper explores the effect of the capacitor bank on the electrical network and the electrical network on the capacitor bank in the nonsinusoidal mode. The paper presents the overview of publications, the results of measurements of the power quality indices, obtained during experimental study of the effect of the capacitor bank on the network mode, methodical approach for predicting harmonic resonance, the analysis of the parameters of the mode and of the network node with the capacitor bank using the “Harmonics” software package, assessments of resonant powers and the service life of the capacitor bank.

## 2 Relevance of harmonic resonances in electrical networks

One of the problems of the nonsinusoidal modes relates to capacitor banks in electrical networks. Capacitor banks regulate the voltage value in the network nodes and allow obtaining the normative value of the power factor. The electrical network and the capacitor bank at harmonic frequencies create resonant circuits [6, 7, 9-11].

If there are current harmonics in the electrical network, on which resonant circuits have formed, then currents and voltages increase on these harmonics. That is why the authors of [7] write that current resonances are especially dangerous for static capacitors. The authors of [12] note that current harmonics overload capacitor banks and damage them.

\*Corresponding author: [kovernikova@isem.irk.ru](mailto:kovernikova@isem.irk.ru)

Regulatory documents on the electric power industry for many years indicate the need to take into account resonant modes at harmonic frequencies. The 2003 regulation states [13]: “The nonsinusoidality of the voltage at the point of common connection can be created both by distorting consumer electrical receivers and by equipment of power supply organizations operating in modes that contribute to the appearance of resonant modes”. The current document “On a unified technical policy in the power grid complex” indicates: “The use of the capacitor bank is allowed provided that resonance phenomena are excluded under all operating modes of the electrical network” [14].

The authors [10, 15-19] in their papers pay great attention to the prediction and detection of resonant modes in electrical networks at harmonic frequencies. The authors of [10] proposed to use the frequency scanning method to detect the resonant circuit. They used impedance charts to establish the resonant mode. Large impedance values characterize parallel resonances. They form peaks on the chart. Small impedance values characterize series resonances. They form troughs on the chart. The authors of [15] developed a model of the electrical network to predict the values of voltage and current harmonics. They made special measurements on this network to verify the model. The electrical network where took measurements consisted of the electrical system, a transformer, a 500 kV power line, which formed the resonant circuit at the 5-th harmonic. The authors of [16] studied the harmonics of voltages and currents in high-voltage networks under resonant phenomena. They used the theory of long lines in their research. The authors studied the influence of the network configuration on the input impedance near resonant frequencies. They found that when the network configuration changes, the increase in the harmonics of currents and voltages is possible. The authors of [17] presented the results of studies of parallel resonance with the controlled 12-stage capacitor bank. They found that each stage of the capacitor bank creates the resonance at the certain frequency. The authors of [18] note that interest in harmonic resonances has increased due to the use of power electronics in all areas of human activity. For example, damage to communication systems equipment occurs in resonant modes due to overvoltages and interference. Interference distorts information transmitted over power lines and recorded by smart meters. The authors of [19] studied harmonic resonances in urban networks. They note that they arise due to the electronic equipment of households. The authors point out those harmonic resonances in low voltage networks must be taken into account when planning networks.

### 3 Results of experimental studies of the effect of the capacitor bank on the power quality

Power quality indices were measured to evaluate the effect of the capacitor bank on voltage waveform distortion. The indices of the  $n$ -th voltage harmonic

factor ( $K_{U(n)}$ ) and the total harmonic distortion ( $K_U$ ) were measured. The state standard [1] establishes for the values of power quality indices  $K_{U(n)}$  and  $K_U$  for 95% and 100% of the measurement time the normative values –  $K_{U(n)N95}$ ,  $K_{U(n)N100}$ ,  $K_{UN95}$ ,  $K_{UN100}$ .

The capacitor bank is installed in the 110 kV network at the substation of the network organization. The measurements were carried out on 110 kV buses of a railway traction substation. The 110 kV transmission line 200 meters long connects the buses of the traction substation with the 110 kV buses of the network organization, where the capacitor bank is connected.

Figure 1 shows a fragment of the network scheme, where the capacitor bank is connected at node 1980, and measurements were taken at node 1981. The notations used in the scheme are: PS – power system, EN – electrical network.

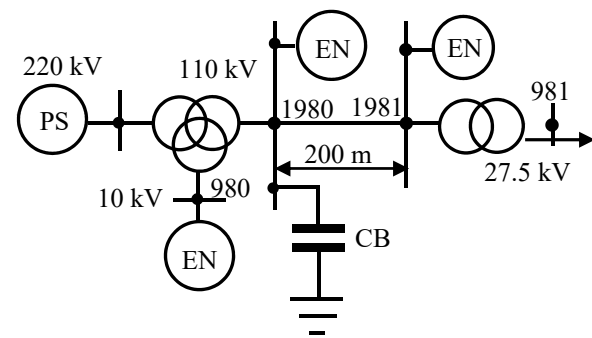

Fig.1. Fragment of the network scheme.

The measurement results are shown in Fig. 2-7. The capacitor bank switches on at the nineteenth minute. Charts of  $K_{U(3)}$  and  $K_{U(5)}$  for three phases (A, B, C) and the normative values established for them in [1] are shown in Fig. 2 and Fig. 3. Power quality indices  $K_{U(3)}$  did not exceed  $K_{U(3)N95}$  before switching on the capacitor bank. They have exceeded the normative value  $K_{U(3)N100}$  after switching on the capacitor bank. Power quality indices  $K_{U(5)}$  before switching on the capacitor bank exceeded the normative value  $K_{U(5)N95}$ , after switching on the capacitor bank they began to exceed  $K_{U(5)N100}$ .

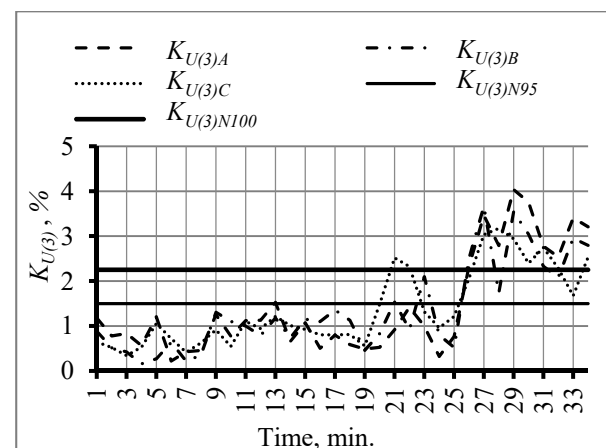
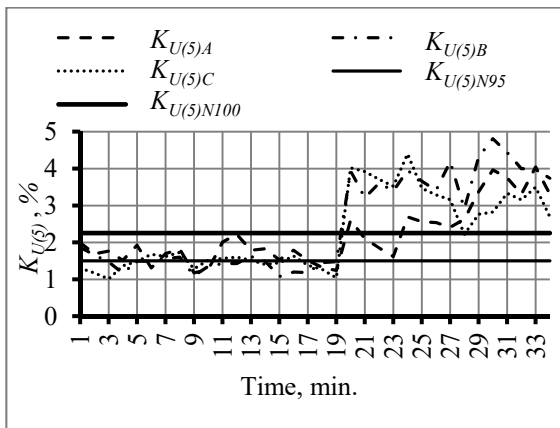
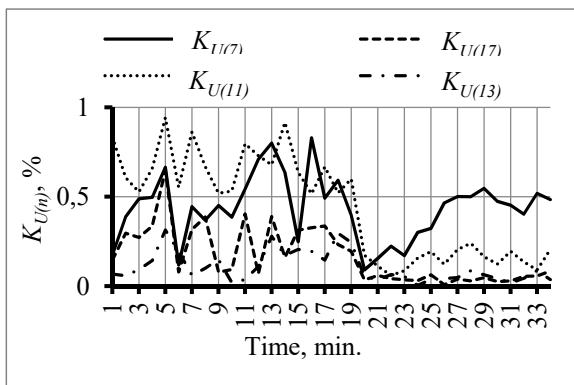

Fig. 2. Measured power quality indices of  $K_{U(3)}$ .

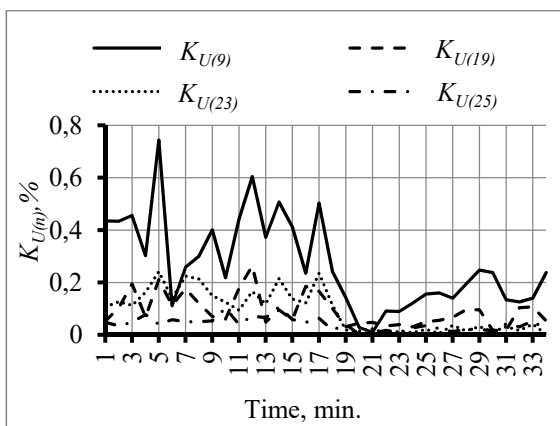

**Fig. 3.** Measured power quality indices of  $K_{U(5)}$ .

Figures 4 and 5 show charts of power quality indices for one of the phases. Different normative values in the range from 0.5% to 1% are established for the power quality indices in Fig. 4 [1]. The measured power quality indices did not exceed the normative values  $K_{U(n)N95}$  before switching on the capacitor bank, their values decreased after the capacitor bank was switched on. The normative value  $K_{U(n)N95}$  for the power quality indices in Fig. 5 are 0.4% [1]. They exceeded the normative



**Fig. 4.** Measured power quality indices of  $K_{U(7)}$ ,  $K_{U(11)}$ ,  $K_{U(13)}$ ,  $K_{U(17)}$ .

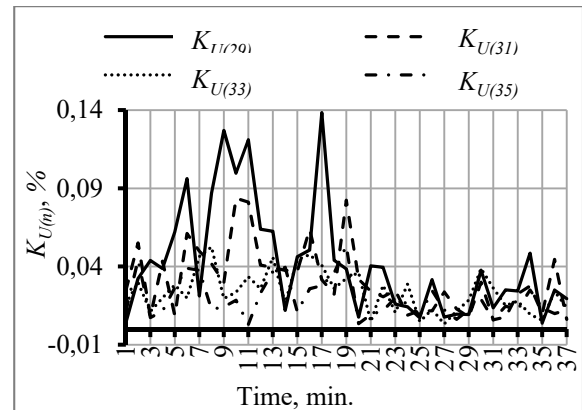

**Fig. 5.** Measured power quality indices of  $K_{U(9)}$ ,  $K_{U(19)}$ ,  $K_{U(23)}$ ,  $K_{U(25)}$ .

value before switching on the capacitor bank only for the 9-th harmonic. They became less than the

normative value at all harmonics after switching on the capacitor bank.

All power quality indices in Fig. 6 are less than the normative values  $K_{U(n)N95}$  equal 0.2% and 0.4% both before switching on and after switching on the capacitor bank.



**Fig. 6.** Measured power quality indices of  $K_{U(29)}$ ,  $K_{U(31)}$ ,  $K_{U(33)}$ ,  $K_{U(35)}$ .

The values of  $K_U$  in the three phases are shown in Fig. 7. They exceeded the normative value  $K_{UN95}$  before the capacitor bank was switched on and exceeded  $K_{UN100}$  after it was switched on.

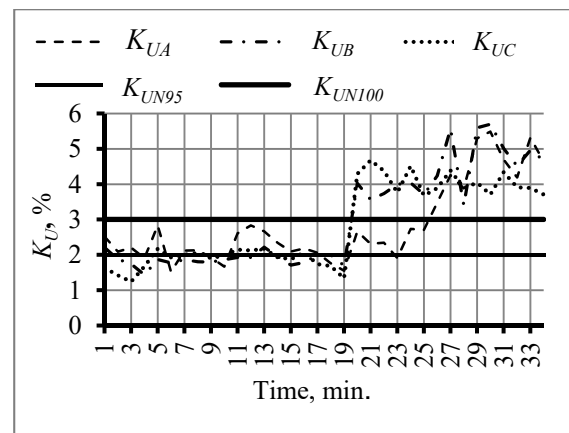

**Fig. 7.** Measured power quality indices of  $K_U$ .

## 4 Methodical approach to the analysis of harmonic resonances

A resonant circuit occurs when the values of the inductive and capacitive elements of the electrical circuit are equal [20]. The phase difference between voltage and current at the input of the resonant circuit is equal to zero. If the inductive and capacitive elements are connected in series, then a series resonance occurs, i.e. voltage resonance. The impedance of the resonant circuit is active, the current in the circuit is the largest, and large voltage drops occur on the inductive and capacitive elements. When the inductive and capacitive elements are connected in parallel, a parallel resonance occurs, i.e. current resonance. The susceptance of the circuit becomes

equal to zero. The admittance is active and minimal. Parallel connection of inductive and capacitive elements creates the large resistance. The current in the common branch is the smallest, but it is possible to increase it in reactive elements. If there is the capacitor bank in the network, resonance occurs between the capacitance of the capacitor bank and the inductance of the electrical network at the connection point of the capacitor bank.

To analyse harmonic resonances, it is necessary to calculate the network mode at the harmonic frequency, as well as conductance, susceptance, and admittance of network nodes, voltage harmonics, power quality indices and power of capacitor banks at which resonance occurs. All the above parameters can be calculated using the system of matrix equations [21]

$$\mathbf{U}_n = \mathbf{Z}_n \mathbf{I}_n, \quad (1)$$

where  $\mathbf{n}$  – the harmonic number;  $\mathbf{U}_n$  – the column-matrix of voltage phasors at network nodes to be determined;  $\mathbf{Z}_n$  – the square matrix of self- and mutual impedances of network nodes, which is obtained as result of inversion of nodal admittance matrix  $\mathbf{Y}_n$ ;  $\mathbf{I}_n$  – the column-matrix of currents phasors at network nodes representing non-linear loads, which should be determined from the results of measurements of current harmonics [22].

Matrix  $\mathbf{Y}_n$  is formed according to the known parameters of the electrical network elements [21].

To establish the presence of the resonant circuit, the frequency response of the following parameters of the network node is calculated: the admittance ( $y_n$ ), the conductance ( $g_n$ ), the susceptance ( $b_n$ ).

$$y_n = 1/z_n \quad (2)$$

$$g_n = r_n/z_n \quad (3)$$

$$b_n = x_n/z_n \quad (4)$$

The reactance  $x_n$  can be inductive, i.e.  $x_n = \omega nL$ , and capacitive i.e.  $x_n = -1/(\omega nC)$ ,  $\omega = 2\pi f$ ,  $f = 50$  Hz. The impedance  $z_n$  is calculated from expression (5).

$$z_n = [(r_n)^2 + (x_n)^2]^{1/2} \quad (5)$$

To assess the effect of harmonic resonance on voltage harmonics at the network nodes, the power quality indices  $K_{U(n)}$  are calculated in accordance with [1].

The experience of studying harmonic modes shows that most often  $K_{U(n)}$  exceed the normative values of 3, 5, 7, 9, 11, 13, 17, 19, 23, 25-th harmonics. Resonance circuits arise not only on harmonics, but also on interharmonics. The frequency scanning method is implemented in the “Harmonics” software package to determine the numbers of resonant harmonics and interharmonics using frequency response  $y_n$ ,  $r_n$ ,  $b_n$  [23]. The “Harmonics” software package determines the nodes of the network with resonant circuits, and calculates the parameters of the network and network modes.

The algorithm for analysing harmonic resonance in the connection node of the capacitor bank using the “Harmonics” software package is given below:

1. Input information on the electrical network.
2. Setting the interval of studied harmonics [ $n1$ ,  $n2$ ] and harmonic scanning step  $\Delta n$ .
3. Formation of the matrix  $\mathbf{Y}_n$ .
4. Calculation of the elements of the matrix  $\mathbf{Z}_n$ .

5. Calculation of  $y_n$ ,  $g_n$ ,  $b_n$  for the network node in which the capacitor bank is connected.

6. Calculation of  $U_n$ ,  $K_{U(n)}$  for the network node in which the capacitor bank is connected.

7. Checking condition  $n \leq n2$ . If the condition is not met, then return to step 2. If the condition is met, then go to step 8.

8. Analysis of the calculated susceptance values  $b_n$  to determine the number of the resonant harmonic.

9. Calculation of the power of the capacitor bank at the resonant harmonic.

10. Calculation of the multiplicity of reduction in the service life of the capacitor bank at the resonant harmonic.

11. Output of calculation results.

Additional losses of active power appear in the insulation of the capacitor bank with the nonsinusoidal voltage at its terminals. They increase the operating temperature of the insulation, which shortens its service life and, as the result, the service life of the capacitor bank.

The authors of [7] propose to use the multiplicity of the service life reduction ( $y$ ) to assess the effect of the nonsinusoidal voltage on the capacitor bank. It is calculated by expression (6).

$$y = 1/z, \quad (6)$$

where  $z = Z/Z_s$  is the relative reduction in the service life of the insulation,  $Z = C \exp(-bt)$  and  $Z_s = C \exp(-bt_s)$  - service life of the insulation at temperature differences between the hottest point of the capacitor and the environment for nonsinusoidal voltage  $t$  and for sinusoidal voltage  $t_s$ . After transformations,  $z$  takes the form

$$z = \exp(-b\Delta t), \quad (7)$$

where  $\Delta t = t - t_s$ ,  $b = 0.086$ .

The value of  $b$  is determined by the Montzinger rule, which establishes that “an increase in temperature by 8°C compared to the permissible temperature reduces the service life of the insulation by 2 times”. The temperature drop  $\Delta t$  is proportional to the power losses from voltage harmonics and in [7] is calculated as

$$\Delta t = t_s \left( \sum_{n=2}^{40} n U_n^2 \right). \quad (8)$$

As a result, the multiplicity of the reduction in the service life of the capacitor bank will be determined as

$$y = \exp[bt_s \left( \sum_{n=2}^{40} n K_U^2 \right)]. \quad (9)$$

## 5 Example of analysis of harmonic resonance in the network node with the capacitor bank

The analysis of harmonic resonance was made for the node 1980 of the electrical network, the fragment of which is shown in Fig. 1. Calculation of parameters for the analysis of harmonic resonance with the help of the “Harmonics” software package was carried out in accordance with the algorithm. The network scheme for calculation has 174 nodes, 217 links, including reactors and capacitor banks, loads represented by

asynchronous motors, active-inductive power loads, sources of harmonics – an aluminium plant and traction loads of the railway.

Figures 8 and 9 show the frequency responses of conductance, susceptance and admittance for the node 1980 with the capacitor bank switched off and on. The change in the nature of susceptance occurs in both cases. At the points of intersection of the susceptance curves with the horizontal axis, which determine the resonant harmonic, the susceptance changes from inductive to capacitive, which corresponds to parallel resonance [20]. Resonance exists at the 17-th harmonic without the capacitor bank (Fig. 8). The susceptance chart of the 1980 node shows that it is inductive at harmonics 3 to 17. The resonant circuit at the 17-th harmonic was formed due to the capacitive elements of the electrical network. Resonance occurs on the harmonic in the range of 3.75-4.00 after switching on the capacitor bank (Fig. 9).

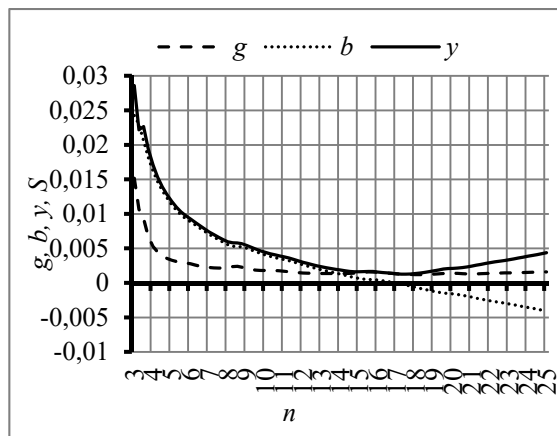

**Fig. 8.** Frequency responses of admittance, conductance, susceptance on the 3–25-th harmonics without the capacitor bank.

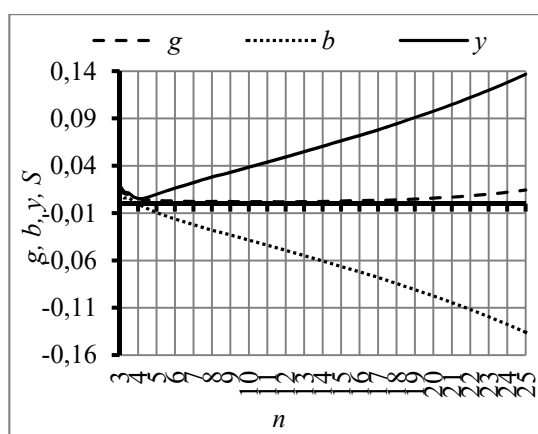

**Fig. 9.** Frequency responses of admittance, conductance, susceptance on the 3–25-th harmonics with the capacitor bank.

The power quality indices  $K_U$  and  $K_{U(n)}$  in the 1981 node and the normative values set for them with the capacitor bank on (CBon) and off (CBof) in the 1980 node are shown in Fig. 10. The diagram shows that the values  $K_U$ ,  $K_{U(3)}$  and  $K_{U(5)}$  exceed their normative

values with the capacitor bank on, as was also obtained as the result of measurements in the 1981 node. The power quality indices do not exceed the normative values for other harmonics.

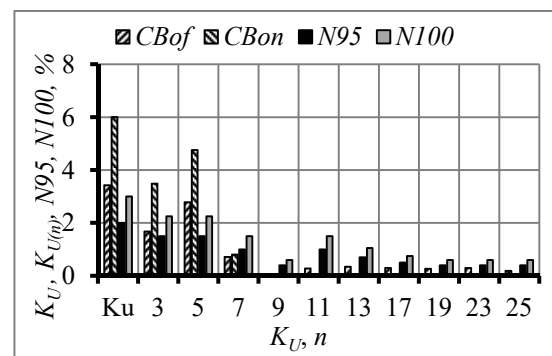

**Fig. 10.** Calculated power quality indices of  $K_U$ ,  $K_{U(n)}$ .

Capacitor bank power ( $Q$ ) for harmonics, on which the capacitor bank in node 1981 would create the resonant circuit with the electrical network, were calculated using the “Harmonics” software package. They are shown in Table 1.

**Table 1.** Resonance powers of the capacitor bank, MVar

$n$	3	5	7	9	11	13	17
$Q$	75	49	27	13	8	6	2.5

To evaluate the effect of voltage harmonics on the service life of the capacitor bank in the 1980 node, the reduction factor of its service life was calculated using expression (9). In the calculation, the measured maximum values of the power quality indices  $K_{U(n)}$  for 40 harmonics in three phases were used. For the capacitor bank with the capacity of 50 MVar, the insulation heat resistance class A was adopted with the allowable temperature of 105°C and the ambient temperature of 45°C [24]. The multiplicity of the reduction in the service life of the capacitor bank is 1.25.

## Conclusion

Harmonic resonances in electrical networks occur randomly with changes in the scheme and parameters of the electrical network, when the capacitor bank is switch on.

When forming the resonant circuit in the electrical network, power quality indices  $K_{U(n)}$  and  $K_U$  exceed the normative values. Significant harmonics of currents and voltages create power losses in the capacitor bank, leading to the reduction in its service life.

The possibility of harmonic resonances should be taken into account when designing electrical networks.

The “Harmonics” software package and the proposed methodological approach to the analysis of resonant modes can be used in managing the power quality in smart grid to predict resonant modes and evaluate their effect on capacitor banks.

The research was carried out under State Assignment Project (No. FWEU-2021-0001) of the Fundamental Research Program of Russian Federation 2021-2030 using the resources of the High-Temperature Circuit Multi-Access Research Centre (Ministry of Science and Higher Education of the Russian Federation, project no 13.CKP.21.0038).

## References

1. State Standard 32144-2013. *Electric Energy. Electromagnetic compatibility of technical equipment. Power quality limits in public power supply systems* (M.: Standartinform, 2014)
2. L.I. Kovernikova, V.V. Sudnova, R.G. Shamonov, et al., *Power quality: current state, outstanding issues, and proposals to their solutions* (Nauka, 2017)
3. L.I. Kovernikova, *Active powers of harmonics in the nodes of connecting non-linear loads to the high-voltage network*, *Elektrichestvo*, No. 3, 12-20 (2017)
4. V.I. Kochkin, *Reactive power in electrical networks. Technologies of controlled compensation*, *Novosti elektrotehniki*, No. 3(51), 1-9 (2008)
5. J. Arrillaga, D. Bradley, P. Bodger, *Power systems harmonics* (Energoatomizdat, 1990)
6. I.V. Zhezhelenko, *Higher harmonics in power supply systems of industrial enterprises* (Energoatomizdat, 2010)
7. A.K. Shidlovsky, V.G. Kuznetsov, *Improving the power quality in electrical networks* (Nauk. Dumka, 1985)
8. E.F. Fuchs, D.J. Roesler, K.P. Kovacs, *Aging of electrical appliances due to harmonics of the power system's voltage*, *IEEE Trans. Power Delivery*, **1**(3), 301-307 (1986)
9. V.E. Tonkal, A.V. Novoseltsev, S.P. Denisyuk, V.Ya. Zhuikov, M.T. Strelkov, Yu.A. Yatsenko, *Energy balance in electrical circuits* (Nauk. Dumka, 1992)
10. IEEE power engineering society, *Tutorial on harmonics modeling and simulation*, IEEE Catalog number: 98TR125-0 (1998)
11. I.I. Artyukhov, I.I. Bochkarev, S.V. Molot, *Problems of the power quality in the power supply systems of gas transmission enterprises with the intensive introduction of frequency-controlled electric drives*, in Proceedings of the International Scientific and Practical Conference "Management of the power quality", Moscow, 23-25 November 2016, Moscow, Russian Federation (2016)
12. V.M. Zyryanov, N.A. Mitrofanov, *Operation of capacitor units under conditions of harmonic distortions of current and voltage curves*, in Proceedings of the International Scientific and Practical Conference "Management of the power quality", Moscow, 05-07 December 2018, Moscow, Russian Federation (2018)
13. RD 153-34.0-15.502-2002. *Guidelines for monitoring and analysing the power quality in public power supply systems. Part 2. Analysis of the power quality* (Moscow: Energoservice, 2003)
14. Regulations of PJSC FGC UES "On the Unified Technical Policy in the Electric Grid Complex", St. Petersburg, Russian Federation (2021)
15. D.K. Geddey, D.C. Smith, P.O. Wright, P.M. Hart, G.E. Littler, *Control of harmonic distortion on Australian Electricity supply networks*, In the book "The impact of high-voltage electrical installations on the environment", 51-59, (Energoatomizdat, 1988)
16. K. Hlava, I. Kabrhel, J. Smid, M. Blasko, *Experimental investigation of harmonic impedances and other electrical parameters of high-voltage network*, In the book "The impact of high-voltage electrical installations on the environment", 59-64, (Energoatomizdat, 1988)
17. T. Vinnal, T. Sakkos, K. Janson, M. Jarkovoi, *Resonances in LV industrial networks when using shunt capacitors for power factor correction*, in Proceedings of 23th International Conference on Electricity Distribution (CIRED), 15-18 June 2015, Lyon, France (2015)
18. L. Eggenschwiler, O. Galland, D. Chollet, F. Decorvet, D. Roggo, P. Favre-Perrod, *Frequency scans and resonance mode analysis for resonance problems identification in power networks in presence of harmonic pollution*, in Proceedings of 24th International Conference on Electricity Distribution (CIRED), 12-15 June 2017, Glasgow, United Kingdom (2017)
19. J. Meyer, R. Stiegler, P. Schegner, I. Röder, A. Belger, *Harmonic resonances in residential low voltage networks caused by consumer electronics*, in Proceedings of 24th International Conference on Electricity Distribution (CIRED), 12-15 June 2017, Glasgow, United Kingdom (2017)
20. L.A. Neiman, K.S. Demirchan, *Theoretical foundations of electrical engineering. Textbook for universities*, **1** (Energoatomizdat, 1981)
21. L.A. Zhukov, I.P. Stratan, *Steady-state operation modes of complex electrical networks and systems: Calculation methods* (Energiya, 1979)
22. L.I. Kovernikova, Van Chung Luong, *Algorithm for modeling non-linear loads of the high-voltage network by measured parameters*, *Elektrichestvo*, No. 10, 16-25 (2017)
23. L.I. Kovernikova, "The "Harmonics" software package for analysis and normalization of harmonic modes in high-voltage networks", in Proceedings of the International Scientific and Practical Conference "Management of the power quality", 23-25 November 2016, Moscow, Russian Federation (2016)
24. Energy-T. Product Catalog. <https://www.energy-t.ru/catalog/krm/batarei-staticheskix-kondensatorov.html>