

# On the feasibility of using distributed generation to tackle the issue of insufficient transmission capacity of power lines in urban area

Gabdushev Dmitry<sup>1\*</sup>, Buslov Victor<sup>1</sup>, Gusev Sergey<sup>1</sup>, Okhlopkov Andrey<sup>2</sup>, Bitney Vladislav<sup>2</sup>

<sup>1</sup>PJSC Rosseti Moscow region, Department of Electrical Modes, Moscow

<sup>2</sup>PJSC Mosenergo, Expertise and Technical Development Service, Moscow

**Abstract.** Issues related to the use of distributed generation for solving the problem of insufficient grid capacity in Moscow are analyzed. The problem area, where the current load of the power transmission line (TL) does not meet the requirements for the mode parameters is considered. The paper proposes an alternative way of tackling this problem by installing a low-capacity gas power plant (GPP) instead of reconstructing the power grid. Results obtained from this study can be used by electricity distribution companies as guidelines for solving the above problem.

## 1 Introduction

Having so many transmission lines that have reached the end of their standard service life poses a problem – insufficient transmission capacity because they were designed for smaller loads 40-50 years ago. Energy intensity and human population have greatly increased since then, thereby imposing a limit on the transmitted power due to technical limitations.

Higher energy efficiency is a characteristic feature of today's energy transition. Distributed generation is a key element of energy efficiency. In this paper, distributed generation refers to power plants located close to the place of energy consumption and connected either directly to the consumer or to the distribution grid [1].

Integration of distributed generation in urban areas is a promising direction for energy development and helps to cope with an intensive increase in load, which is especially characteristic of urban areas. This approach allows to reduce power flows through 35-220 kV distribution grids, which gives significant economic advantages when there is increased power consumption [2-3]. It should be noted that introduction of distributed generation facilities, in addition to postponing the upgrade of transmission lines (investments in such measures are limited) allows for more reliable power supply [4-5].

When laying power transmission lines in major cities, priority is given to cable lines (CL) due to high aesthetic requirements, reduced space and threat to human life in case of emergency. The problem of overcapacity is especially noticeable for cable lines, whose replacement is more costly economically and technically.

A developed power supply scheme for Moscow for 2030, prepared under a state contract by Inter RAO -

Engineering Ltd., shows that insufficient transmission capacity is one of the main problematic aspects of the reliability of power supply to consumers in the Moscow region [6]. Megacities consume more than 75% of the world's primary energy. According to a study [7], this number will only grow. It is in megacities that one gets a high demand for electricity; building new large power plants or upgrading old ones is very expensive and limited by dense buildings.

## 2 Analysis of the Moscow power grid problem area

We consider a network with a lack of capacity. It consists of cable lines (Fig. 1). In one of the cases analyzed, emergency outage (EO) can lead to disconnection of consumers and limit output power.

Power flow distribution, voltages in the network nodes, as well as branch currents under in different EOs in the network are calculated:

Mode 1. Normal network operation mode.

Post-fault modes:

Mode 2. EO CL 220 kV CHP-Main–Raduga No.1 (branch 1-2).

Mode 3. EO, CL 110 kV Raduga–Oranzhevaya, with a tap-off to Zelenaya substation No. 1 (branch 5-12 and 12-8).

Mode 4. EO CL 110 kV Raduga–Oranzhevaya, with a tap-off to Zelenaya substation No. 2 (branch 4-13 and 13-9).

Mode 5. EO busbar section I, 110 kV Oranzhevaya substation.

Mode 6. EO busbar section II, 110 kV Oranzhevaya substation.

Mode 7. EO CL 110 kV Oranzhevaya – generator 2 (branch 9-11).

\*Corresponding author: [gdima512@yandex.ru](mailto:gdima512@yandex.ru)

The computations are summarized in Table 1.

**Table 1.** Results.

TL	Emergency long current overload, %						
	Mode 1	Mode 2	Mode 3	Mode 4	Mode 5	Mode 6	Mode 7
1-2	64.3	0	65.3	65.3	64.6	89.3	65.1
1-3	64.3	128.1	65.3	65.3	64.6	89.4	65.1
4-6	25.9	22.9	25.4	26.4	26.1	26.8	25.9
5-7	23.7	26.8	24.2	23.2	23.5	22.8	23.7
5-12	21.7	21.8	0	45.2	30.0	102.4	24.7
4-13	21.5	19.9	45.2	0.0	32.2	30.0	24.7
13-9	22.7	25.9	43.8	0.0	43.6	0.0	24.4
12-8	20.8	20.0	0	43.8	0.0	73.4	22.5
9-10	54.6	56.3	54.8	54.8	54.7	0.0	88.7
9-11	56.7	58.5	56.9	56.9	56.7	0.0	0.0

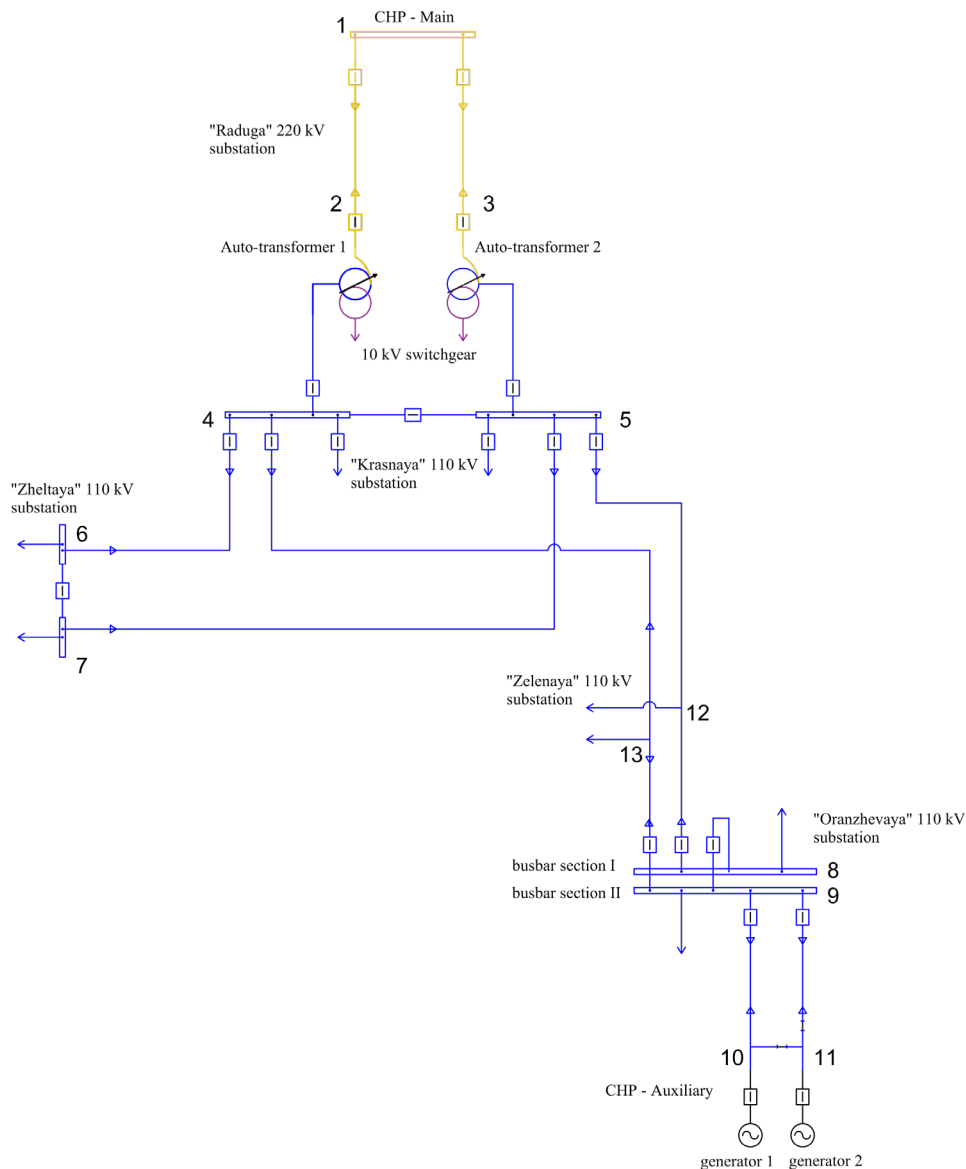

**Fig. 1.** Diagram of the network section

According to the results above, the following most severe modes were identified:

Mode 6: the load of the 110 kV Raduga–Oranzhevaya cable line with a tap-off to Zelenaya substation No.1 does not meet the mode parameter requirements in accordance with GOST R 58670-2019 [8]; the emergency permissible current-transmission capacity was found to have been exceeded.

Mode 2: current in CL 220 kV CHP-Main–Raduga No.2 cable line does not meet the mode parameter requirements in accordance with GOST R 58670-2019 [8]; the emergency permissible current-transmission capacity was found to have been exceeded. All solutions for the 220 kV network are considered a separate investment project and go under a different title. The solution for the 220 kV network is not

considered in this work. This is primarily due to the fact that additional calculations are required for the 220 kV network in this case because the line feeds not only the load on the Raduga substation.

As a solution to the problem of current load exceeding the transmission capacity of lines in the 110 kV network, two options are considered:

1. Installation of a generator on the Zelenaya substation low-voltage (6-20 kV) or high-voltage (110 kV) busbars;

2. Reconstruction of the network section with replacement of the 110 kV cable line of the Raduga–Oranzhevaya substation, with a tap-off to Zelenaya substation No. 1, No. 2.

In both cases, an increase in maximum power consumption in the energy system of Moscow and the Moscow region according to the scheme and development program of the Unified Energy System of Russia (UES SIPR) is taken into account [9].

## 2.1 Installation of a small-capacity power plant on the consumer side

The power plant is installed with a 9.0 MW capacity that is enough to eliminate insufficient capacity at the level of 2032 for various emergency outages.

The generation source is installed on low-voltage busbars (10 kV) of the 110 kV Zelenaya substation. This option was chosen taking into account the following technological features of the substation design:

1. Sectional circuit breakers are installed on low-voltage busbars of the substation. In case of faults on one of the busbar sections (in the event of a voltage loss), the automatic transfer switch (ATS) triggers the operation to supply the load. If a generator is installed on high-voltage busbars in the substation and in case of faults in the line of the busbar section where the generator is installed, the network is deprived of the generator and operates in the same way as in the mode without the generator.

2. The selection took into account that a 6-20 kV cell is cheaper than a 110 kV cell.

3. Installation of the generation source on low-voltage busbars will further relieve the transformer at the substation.

## 2.2 Choice of power generation technology

Moscow has a centralized gas and electricity supply system. On the territory of the problematic section of the network, the place for installation of the generation source is located close to the gas pipeline. So, the power generation technology is chosen from two types: gas turbines (GTs) or gas generators (GGs).

GTs and GGs have their own advantages and disadvantages. During operation, gas engines have vibrations and low-frequency noise, they are of larger sizes relative to GTs, and are inferior to GTs in terms of emissions [10]. However, bringing noise and environmental characteristics to standard values is possible through appropriate engineering solutions

[11]. Differences in the size of GGs compared to GTs when implementing small generation are not significant [12].

Application of GGs is the most profitable for priority power generation [13] due to higher efficiency than that of GTs. GGs can be repaired on site without complex diagnostic equipment once in 7-8 years [11], unlike GTs, whose repair is more complicated and performed by highly skilled specialists, usually at the manufacturer's plant. The efficiency value of GGs decreases by 3-5% when load is reduced to 50% [12]; with GTs at such load reduction, operation in some cases becomes inexpedient due to possible wear and tear of the unit. GTs also require high-pressure fuel gas, so a booster compressor must be installed.

Comparison of gas turbines and gas engines as a part of mini-CHPs in a work by Mutugullina [11] shows that gas turbines should be installed at facilities that have equal electric and thermal needs at over 30-40 MW capacity.

Based on analysis, a 9.0 MW gas power plant consisting of 4 GazEcos 2.25 MW gas generators 16GDG49 (Russian-made) can be installed to reduce the cable line load in the post-fault mode in this network.

To enable the GFPP-9.0 to work as part of an integrated power system, a combined method of regulating the rotational speed and active power of the gas turbine should be used.

For combined regulation under the mode of parallel operation with the power system, the regulation will be carried out according to the law:

$$P_r \rightarrow const, P_r \neq \varphi(f) \quad (1)$$

And in stand-alone (isolated) or island modes according to the law (grid frequency is the controlled parameter) [14]:

$$P_r \rightarrow P_0 \neq \varphi(f) \quad (2)$$

In stand-alone mode, the main task of the automatic control system (ACS) is to regulate the generation of active power, determined by the load magnitude.

Change of one regulation law to another in the ACS occurs automatically according to certain criteria. It is obvious that if the generating unit (GU) suddenly switches from parallel operation with the power system to island mode, then switching from one control law to another should occur quickly enough, and automation should reliably identify such a change in the operating mode of the GU and generate a command to change the algorithm in the ACS.

## 2.3 Reconstruction of a network section

To select a cable with the required transmission capacity, the mode where the current load exceeds the transmission capacity of the lines in the 110 kV network is calculated. The following ground characteristics are taken into account: humidity of normal soil and sand is 7-9% and specific thermal resistance of the ground is 1.2 m·K/W. After determining the cable location and selecting the screen area, a cable for 110 kV with the required core cross-sectional area is selected to solve the problem of insufficient grid transmission capacity. For a 110 kV

cable line, select the cable with cross-linked polyethylene as cable insulation, polyethylene as cable shell (XLPE PE).

### 3 Economic evaluation of both variants

The analyzed period for economic evaluation is 10 years, which corresponds to the practice of planning stage designing of electric networks up to 220 kV [15].

Cost of total capital investments in GPP-9.0 MW is calculated by the formula [16 - 18]:

$$C = C_{EQ} + C_{DW} + C_{CI} + C_{CM} \quad (3)$$

where  $C_{EQ}$  is the cost (in Russian rubles) of equipment of the gas-fired power plant;  $C_{DW}$  – is the cost of design work, which is 5% of the cost (in Russian rubles) of construction and installation work;  $C_{CI}$  is the cost of construction and installation work, equal to 15% of the cost (in Russian rubles) of equipment;  $C_{CM}$  – is the cost of commissioning, equal to 3% of the cost (in Russian rubles) of equipment; Shipping costs are included in the cost of equipment.

The cost of GPP equipment consisting of 4 GazEcos 2.25 MW gas generators 16GDG49 (Russian-made) will be  $\text{P}179,600,000$  [19]. The cost of construction and installation works will be  $\text{P}26,940,000$ . Therefore, the cost of design works will be  $\text{P}1,347,000$ . The cost of commissioning works will be  $\text{P}5,388,000$ .

Capital investments:

$$C = \text{P}179,600,000 + \text{P}1,347,000 + \text{P}26,940,000 + \text{P}5,388,000 = \text{P}213,275,000 \quad (4)$$

**Table 2.** Results of cost-benefit analysis.

Solution method	C, mln. rub.	Costs, mln. rub./year	Revenue, mln. rub./year	$C_{liquid10}$ , mln. rub.	NPV, mln. rub.	PI
Network reconstruction	1008.6	28.2	0	546.3	-950.5	0.06
Installation of distribution generator at the consumer side	213.3	185.0	270.0	71.1	175.2	1.82

The project of installing a small power plant has a better investment appeal. If this project is implemented for the estimated period of 10 years, the investor's company will make an annual profit. At the end of the estimated period, the company's value will increase by  $\text{P}175.2$  million rubles, taking into account the discount rate.

### 4 Implications of scaling this practice for major power generating and grid companies

Apart from optimizing the cost of upgrading grid facilities, the scaling of this alternative solution to the problem of insufficient grid capacity through installation of distributed generation will allow power grid companies to reduce power flows and, consequently, cut losses in distribution grids. The following are other positive effects:

- Higher number of payments for connection to the grid;

GPP's own needs are taken to be 10%. Average annual time of turbines is taken to be 8,000 hours. Revenue from selling electric power per 1 kW is taken according to tariffs in Moscow and Moscow region [20]. Economic evaluation also takes into account the cost for fuel and oil purchase, costs for employee wages, including allocations for social needs. According to directive N 68 by Gosstroy (Russian State Committee for Construction) dated April 3, 2000 [21], the number of personnel working at the GPP with 3 units is taken to be 16 people. Allocations for social needs is 30%. Other costs are taken to be 10%. Depreciation charges are considered a linear method. The service life of GGs is 15 years. The discount rate is taken to be 18.5%.

For the network reconstruction project according to the organizational standards of state-owned energy company FGC UES [22], the aggregated cost of 110 kV cable line with XLPE insulation for cable laying is  $\text{P}16,920,000/\text{km}$  for the year 2000. This cost was converted into current prices in accordance with the letters of the Russian Ministry of Construction. The cable line is 7.8 km long. Since the network is being reconstructed, the cost of construction of collectors and switching points is not taken into account.

The results of cost-benefit analysis for the period of 10 years are given in Table 2, where  $C$  is the capital investment in the project,  $C_{liquid10}$  is the liquidation value for the 10th year, NPV is net present value for 10 years, PI is the project's profitability index (ratio of NPV to capital investments).

- Higher reliability of power supply to consumers in post-fault modes and modes of high risks of power supply disruption (freezing rain, hurricane and other natural and man-made phenomena);

- Normalization of voltage levels in normal and post-fault modes (reduction of on-load tap changers, no need for installation of reactive power compensation equipment);

- Expanding the functions of electric grid organizations. In addition to the basic functions, such as electricity transmission and distribution, connection of new consumers and maintenance of redundancy, new functions are also possible: mutual redundancy, multi-agent response, and demand management [23-24].

The following benefits are created for generating companies:

- Risk diversification, investment optimization;
- Partial solution to the problem of regulating reactive power in the grid and, accordingly, increasing the reliability of generating equipment at major power plants [25];

- Business expansion, opening of new strategic prospects for the company's development in connection with the inevitable energy transition;

- Occupying a position in a new niche, which is developing in view of the growing number of implemented distributed generation facilities in Europe; forming a strong competitive position in comparison with other players thanks to greater industry experience;

- Introduction of distributed generation will compensate for a part of the required generating capacity due to exhaustion of a thermal power station's own resource [1].

Despite the positive effects, introduction of distributed generation to solve the problem of insufficient capacity in a distribution grid also poses new challenges to the power system as a whole. There remains the problem of dynamic stability of the grid and the need to limit short-circuit currents with significant scaling of this practice. However, implementation of this solution in particular cases, instead of reconstructing the grid due to the smallness of the generation source, will not significantly affect the network.

## 5 Conclusion

When considering a problematic section of Moscow's power grid, in which the current load in the transmission line does not meet the mode parameter requirements, an alternative way of solving this problem was proposed – installation of a low-capacity GPP instead of reconstructing the network.

Installation of a gas-fired mini-TPP in the example under consideration has a higher investment appeal than solving the problem in the traditional way, network reconstruction.

Integration of distributed generation to solve one of the problems of electric grid companies with the involvement of generating companies, creates a combination of advantages and opportunities for both parties. However, introduction of distributed generation also comes along with new challenges that need to be addressed.

Results obtained from this study can be used by electric grid companies as guidelines for solving the problem of insufficient grid capacity in problem areas through integration of distributed generation, in addition to traditional methods.

## References

1. Khokhlov A., Melnikov Y., Veselov F., Holkin D., Datsko K. *Distributed Energy in Russia: Development Potential*. Moscow: Energy Center, Skolkovo Moscow School of Management, 2018. pp. 87.
2. Krylov P. A. Peculiarities of parallel operation of low-power generation sources with a powerful grid. Siberian Federal University, Krasnoyarsk, April 15-25, 2016. pp. 46.

3. Features of integration and prospects for effective use of distributed generation facilities in Russia's electric power system: Minutes of joint meeting No. 5/18 of October 18, 2018 of the Scientific and Technical Board of Unified Energy System and the Section on Reliability and Safety of Large Energy Systems, Scientific Council of the Russian Academy of Sciences on integrated energy problems. Moscow, 2018. pp. 16.
4. Boljevic, S., & Conlon, M. (2009). Fault current level issues for urban distribution network with high penetration of distributed generation. 2009 6th International Conference on the European Energy Market. doi:10.1109/eem.2009.5311425
5. Byk F.L., Myshkina L.S. Reliability of distributed power facilities. *Reliability and Safety of Energy*. 2021, 14 (1) pp. 45-51.
6. Inter RAO - Engineering Ltd. Scheme of power supply for Moscow (distribution networks with 6-10-20 kV voltage) for the period up to 2030, taking into account connected territories. November, SEM.6-10-20kV-PZ-v2. Online: [https://www.mos.ru/upload/documents/oiv/tom\\_3\\_compressed.pdf](https://www.mos.ru/upload/documents/oiv/tom_3_compressed.pdf)
7. Allam Z. Enhancing renewable energy adoption in megacities through energy diversification, land fragmentation and fiscal mechanisms // *Sustainable Cities and Society*. 2019, V. 101841.
8. Calculations of electric power modes and determination of technical solutions for prospective development of power systems. GOST R 58670-2019
9. Scheme and Program for the Development of the Unified Energy System of Russia in 2021-2027. Approved by the Ministry of Energy of Russia, No. 88, February 26, 2021
10. Chigvintseva I.R., Burganov E.F. Monitoring of parameters of HPP power plant operation. *Vestnik of Kazan Technological University*, 17 (11), 2014. pp.188-190.
11. Mutugullina I. A. Comparative analysis of gas engine and gas turbine units in the context of solving energy saving problems. *Vestnik of Kazan Technological University*, 2014. V. 17 (12), pp. 373-375.
12. Korolenko T.V., Alekseeva O. C. Prospects for the introduction of gas engine-powered mini-CHP, 2019.
13. Belkin A. P., Dubova A. V. Evaluation of the Efficiency of Transition to Decentralized Energy Supply in Tyumen Oblast. *Vestnik of Ivanovo State Energy University*, 2016. No. 2, pp. 5-13.
14. Gurevich Y. E., Ilyushin P.V. Features of mode calculations in power districts with distributed generation. Nizhny Novgorod: Nizhny Novgorod Institute of Management, Russian Academy of National Economy and Public Administration under the President of the Russian Federation, 2018, pp.280. ISBN 978-5-00036-226-6, EDN YWRPSP

15. Glazunov A.A., Shvedov G.V. Designing a district electrical network. MPEI, 2010.
16. Masleyeva O.V., Agaltsova T.A., Erdili N.I. Ecological and Economic Assessment of the Life Cycle of Traditional Energy Sources and Bioenergy. Proceedings of Nizhny Novgorod State Technical University, 2019. No. 1 (124). pp. 119-129. EDN: ZANGKD.
17. Generating systems based on gas engine and gas turbines. Developer: Energy Service Center, Siberian Energy Center. [Electronic resource] <https://nppsibec.ru/wp-content/uploads/2019/09/sistemy-kogeneraczii-na-osnove-gazoporshnevyyh-i-gazoturbinnyyh-ustanovok.pdf> (accessed October 6, 2022)
18. Price list for gas engine power plants (Mini-CHPs) and diesel generators [Electronic resource] [https://www.d-system.ru/money/?etext=2202.k8NPMv980pIWU7EMjHiNNrI0pRPcawUDVPWBxM12\\_WZ4YXFqY2tqZHZ1a3hxaHZ3.0f611771298d326202b622d508e2f4c4ef9e51d4&yclid=5873033669814323375/](https://www.d-system.ru/money/?etext=2202.k8NPMv980pIWU7EMjHiNNrI0pRPcawUDVPWBxM12_WZ4YXFqY2tqZHZ1a3hxaHZ3.0f611771298d326202b622d508e2f4c4ef9e51d4&yclid=5873033669814323375/) (accessed October 6, 2022)
19. GazEcos 2.25 MW 16GDG49 - power supply systems [Electronic resource] [https://www.gazecos.ru/calc\\_kvh.html](https://www.gazecos.ru/calc_kvh.html) (accessed October 6, 2022)
20. Full version of tariffs for 2022 [Electronic resource] <https://www.mosenergosbyt.ru/individuals/tariffs-n-payments/tariffs-mo/polnaya-versiya-tarifov-mo.php> (accessed: July 12, 2022)
21. Order N 68 of the State Committee for Construction of the Russian Federation dated April 3, 2000 "On approval of the Guidelines on labor rationing in the energy sector. Part 3. Standards for the number of employees of utility electric power enterprises
22. Aggregated cost indicators for power transmission lines and substations with a voltage of 35-1150 kV. Standards of FGC UES, 2012.
23. Byk F.L. et al. Functions of Regional Grid Companies in the Integration of Local Power Systems. Transmission and Distribution, 2020, No. 2. pp. 48-55.
24. Byk F.L., Myshkina L.S. Development of distributed energy and increase in electric grid efficiency. Business. Education. Law. 2019, No. 4. pp. 134-138.
25. Impact of operation mode in terms of reactive power regulations on technical condition and reliability of generating equipment operation / S. Lenev, A. Vivchar, A. Okhlopkov, V. Bitney // Proceedings of the 2022 4th International Youth Conference on Radio Electronics, Electrical and Power Engineering, REEPE 2022 : 4, Moscow, 17–19 марта 2022 года. – Moscow, 2022. – DOI 10.1109/REEPE53907.2022.9731385. – EDN JGBMNI.