

Influence of the consumer to power quality at the point of connection

Makhsud Bobojanov^{1*}, Sultonkhuja Mahmutkhonov¹

¹Tashkent State Technical University named by Islam Karimov, Tashkent, 100095, Uzbekistan

Abstract. This article is devoted to the development of a method for assessing the impact of consumers on the deterioration of the quality of electricity in the power supply system by using equivalent circuits. When developing a method for assessing the impact of the consumer on the quality of electricity, the main factors from the electromagnetic compatibility criteria were taken into account. A method has been developed for assessing the work of a consumer in terms of voltage quality at a common connection point, which was verified using the equivalent circuit method, using the developed method, it is possible qualitatively and quantitatively assess the impact of each consumer on the emergence unacceptable voltage higher harmonic.

1 Introduction

The development of new technologies has led to increased requirements for the electromagnetic environment. The requirements of (standards) GOST 13109-67 from 1967 for power quality were revised in 1987 due to the development of semiconductor technology and revised again in 1997 due to the development of microprocessor technology [1,3].

Quality indicators of electric energy are determined according to "Electromagnetic compatibility of technical equipment of electric energy, quality norms of electric energy in general electric supply systems" and International Standard 32144-2013 [1- 5].

Consumers of electric energy can fully perform the tasks assigned to them only under certain conditions. The parameters determining such conditions are called power quality. Deviation of quality marks in any direction causes inefficient use of electricity. It also causes less effective use of electrical devices and equipment and less output.

Non-compliance with the requirements of the PQ leads to significant material damage associated with a decrease in the service life and failure of electrical equipment, an increase in electricity losses and the appearance of defective products, improper operation of relay protection devices [3-15].

2 Method of assessing the impact on the disorder to power quality from consumers at the point of connection

A common feature of the methods of assessing the impact of consumers on power quality disturbances is

that the voltage quality disturbances at the node of the electric network are considered a priori to include the share contribution of individual consumers. In other words, the violation of the quality of voltage is additive. For such systems, the principle of superposition is valid, i.e. the reaction of the system to any combination of external influences is equal to the sum of the reactions to each of these influences separately.

Additivity is the value of a quantity that corresponds to the whole object is a property of mathematical or physical quantities consisting of the sum of the values of the quantities corresponding to its parts. It can be seen that the concept of the share contribution of the consumer can be called additive only if it is proved that the power quality violation has an additional property.

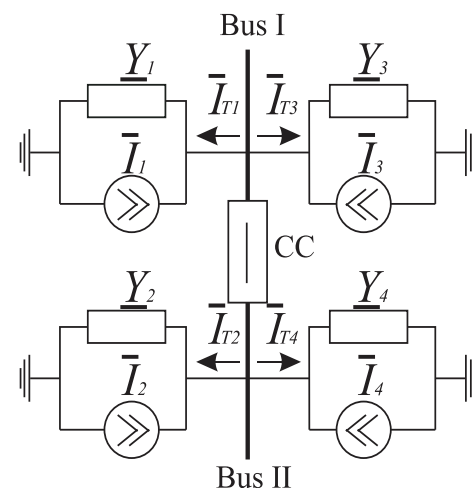

Fig. 1. Equivalent circuit of subjects

* Corresponding author: Sultonmk@mail.ru

As mentioned above, in order to determine the influence of non-sinusoidal and non-symmetry of the voltages at the point of connection of consumers in the power supply system, the switching scheme of each object is used in the studied harmonic or in the active bipolar form for reverse sequence currents with the main frequency. In the case shown in Fig.1, 4 consumers are connected to a point of connection. Here, all parameters are assumed to be related to the studied higher harmonic or the reverse sequence of the fundamental frequency.

I_1, I_2, I_3, I_4 - sources of current quality disturbance (harmonic current or reverse sequence current) set for the average interval set in the switching scheme; Y_1, Y_2, Y_3, Y_4 - power supply system conductivities. In the power supply system, linear (symmetric) consumers are represented only by conductance in the switching scheme, and a non-linear or symmetrical consumer is represented as a current source. Using the example of the equivalent circuit in Fig. 1, to prove the additivity or non-additivity of the voltage quality violation, it is necessary to compare the voltage quality violation UPOC when all consumers work together with the sum of the voltage quality violations U_{1SS} and U_{2SS} created by consumers. If the section breaker (SB) is off, a comparison is made on each of the two bus sections.

This voltage is found from the following formula:

$$\begin{aligned} U_{POC} &= \frac{I_1 + I_2 + I_3 + I_4}{Y_1 + Y_2 + Y_3 + Y_4}; \\ U_{ISB} &= \frac{I_1 + I_3}{Y_1 + Y_3}; \\ U_{2SB} &= \frac{I_2 + I_4}{Y_2 + Y_4}; \end{aligned} \quad (1)$$

The sum of U_{1SS} and U_{2SS} does not give the voltage value U_{POC} at the point of connection when a sectional breaker is added.

The obtained result shows that the disturbance of voltage quality is not addictive. Therefore, it is wrong to use concepts about the contribution or share of the consumer in the violation of voltage quality. The method of determining the share contribution is imperfect because it does not correspond to the processes that occur in the network at high harmonics and cannot be used to assess the effect of consumers on voltage disturbances. In this regard, the assessment of the consumer's impact should be done in a different way, which does not use the concept of "share contribution" and takes into account the non-addictiveness of voltage quality violations.

There are two important factors to consider when developing an impact assessment method. On the one hand, the impact assessment should be autonomous according to the principles of electromagnetic compatibility. This means that each consumer should only be responsible for the quality-degrading current and conductivity of the controlled switching circuit parameters. On the other hand, the influence of the consumer on the level of high harmonics and voltage asymmetry depends not only on its parameters, but

also on the parameters of the switching circuits of other consumers at a certain common connection point, as well as on the parameters and scheme of the external power network. Therefore, it is necessary to develop a method that clearly ensures the above two factors and the responsibility for improving the quality of electricity between consumers and electricity supply companies [2-3,5].

A method has been developed that does not use the concept of proportional contribution and takes into account the non-addictiveness of the voltage at the common connection point to assess the effect on voltage quality degradation by consumers.

$$U_{poc} = \frac{I_1 + I_2 + I_3 + \dots + I_N}{Y_1 + Y_2 + Y_3 + \dots + Y_N} = \frac{\sum_{m=1}^N I_m}{\sum_{m=1}^N Y_m} \quad (2)$$

A scheme similar to that shown in Fig.1 was adopted as the initial switching scheme. In general, the voltage quality impairment value at the common connection point for N power consumers is determined by formula (2). Based on this formula, all power supply consumers can change both the sign and the denominator of this expression, so they affect the magnitude of the voltage quality violation.

It should be noted that the modules and arguments of quality-destroying currents are not the same for each of the conductivities I_m and Y_m , harmonics of consumers of power supply enterprises.

Therefore, expression (2) is written separately for each of the analyzed higher harmonics and the inverse sequence constituents of the fundamental frequency and its analysis is carried out.

$$\begin{aligned} I_E^\Gamma &= I_1 + I_2 + I_3 + \dots + I_N = \sum_{m=1}^N I_m; \\ Y_E^\Gamma &= Y_1 + Y_2 + Y_3 + \dots + Y_N = \sum_{m=1}^N Y_m; \\ I_E^A &= I_1 + I_2 + I_3 + \dots + I_N = \sum_{m=1}^N I_m; \\ Y_E^A &= Y_1 + Y_2 + Y_3 + \dots + Y_N = \sum_{m=1}^N Y_m; \end{aligned} \quad (3)$$

here I_Σ^Γ and Y_Σ^Γ is a geometric (vector) sum of quality-destroying currents and conductivities of power supply system consumers;

I_Σ^A and Y_Σ^A – the arithmetical sum of quality-disrupting currents and conductivities of power supply system consumers.

From this can be form the following expression:

$$K_{CI} = \frac{|I_\Sigma^\Gamma|}{I_\Sigma^A}; K_{CY} = \frac{|Y_\Sigma^\Gamma|}{Y_\Sigma^A} \quad (4)$$

Here K_{CI} , K_{CY} are the current and conductivity coefficients in the phase, respectively.

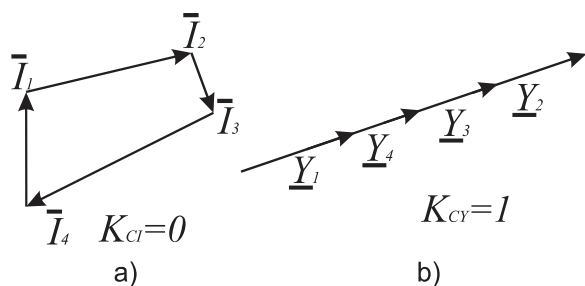

Fig.2. Geometric representation of phase matching coefficients

a) $K_{Cl} = 0$ b) $K_{cY} = 1$

The phase matching coefficients describe the mutual location of currents and conductance vectors that violate the power quality in the complex plane and can take values from 0 to 1. Thus, Figure 2.- a shows one of the cases where the vector sum of the currents is zero, and the coincidence coefficient in the phase of the quality-disrupting currents is also zero. Figure 2-b shows an example where all conductances of consumers of the power supply system match in phase and $K_{cY} = 1$.

From the expression (4), the following can be obtained:

$$|I_{\Sigma}^I| = K_{Cl} \cdot I_{\Sigma}^A; \quad |Y_{\Sigma}^I| = K_{Cl} \cdot Y_{\Sigma}^A \quad (5)$$

Taking into account the expressions (2) and (5), the expression of the breakdown voltage modulus at the common connection point is as follows:

$$U_{poc} = \frac{K_{Cl} I_{\Sigma}^A}{K_{cY} Y_{\Sigma}^A} \quad (6)$$

Introduce the concept of the profit factor:

$$K_{profit} = \frac{K_{cY}}{K_{Cl}} \quad (7)$$

From (6) can be form the following expression:

$$U_{poc} = \frac{1}{K_{profit}} \cdot \frac{I_{\Sigma}^A}{Y_{\Sigma}^A} \quad (8)$$

The profit factor can take values from 0 to $+\infty$. This shows how beneficial it is for consumers in the electricity supply system to work together in this best equivalent scheme.

3 Verification of the method using an equivalent circuit

To explain how useful is it to work together in an equivalent circuit using Fig. 2. for two cases. Figure 2, (a) shows the case where profit factor $K_{profit} = 0$, that is, the utility of joint work is zero. Expressions (7) and (8) show that this parameter corresponds to $K_{cY} = 0$, and the geometric sum of conductivities is zero.

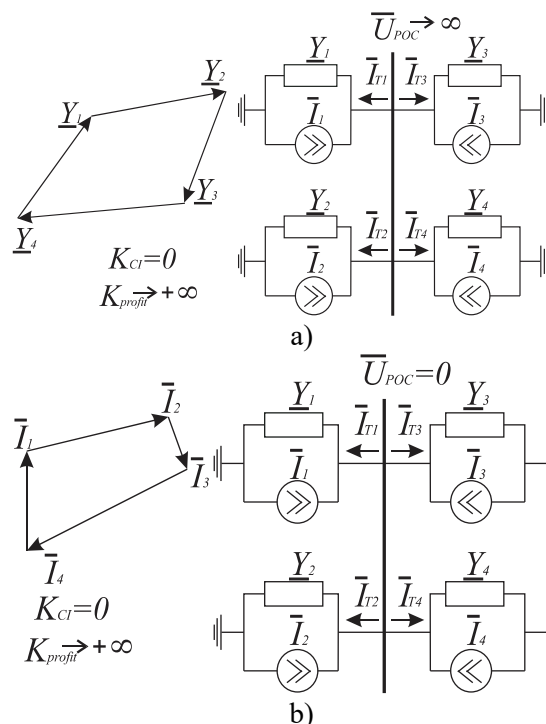

Fig. 3. A graph of the values of the profit factor
 a) $K_{profit} = 0$ b) $K_{profit} \rightarrow +\infty$

This means that there is a resonance of the currents, and when $K_{profit} = 0$, the breakdown of the quality of the voltage at the point of connection U_{poc} tends to infinity.

At the same time, all connected to the point of connection suffer from non-compliant power quality indicators, which confirms that it is inappropriate for consumers to work together in this mode. Figure 2-b shows the case where K_{profit} tends to $\rightarrow +\infty$.

According to (8), this means that K_{cl} is zero (Fig. 2, a), and therefore violation of the voltage quality (10) is also zero.

In general, the admissible condition for voltage quality failure mode is the inequality:

$$U_{poc} \leq U_{permv} \quad (9)$$

here U_{prsv} is the permissible value of the n- th harmonic component of voltage or the reverse sequence of voltage determined by the K_{Un} and K_{2U} coefficients.

Thus, with a certain normal permissible value of the $K_{UN} N_D$ coefficient and the nominal voltage U_{nom} at the point of connection, the value of U_{permv} is equal to:

$$U_{n.per} = \frac{K_{un} N_D \cdot U_{nom}}{100\%} \quad (10)$$

Similar to the expression (10), using K_{2U} , it is possible to find the permissible value of the reverse sequence of the voltage at the fundamental frequency U_{mf} .

Taking into account (3) and (8), we can write:

$$\frac{1}{K_{profit}} \cdot \frac{I_1+I_2+I_3+\dots+I_n}{Y_1+Y_2+Y_3+\dots+Y_n} \leq U_{prsv} \quad (11)$$

From (11) we get:

$$K_{eff}U_{prsv}Y_1 - I_1 + K_{eff}U_{prsv}Y_2 - I_2 + \dots + K_{eff}U_{prsv}Y_n - I_n \geq 0 \quad (12)$$

A necessary condition for the admissibility of the breakdown voltage regime is the observance of inequalities (9) - (12). A sufficient condition for the fulfillment of the inequality (12) is that the expression on the left side is non-negative at each value of the sum. This condition is reasonable because it provides the same requirements for all consumers of the power supply system, regardless of their capabilities and other parameters. All N power consumers connected to a point of connection are responsible for keeping U_{poc} within acceptable limits. Thus, for the k-th consumer of the power supply system taken separately, we can write the following expression:

$$K_{eff}U_{prsv}Y_k - I_k \geq 0 \quad (13)$$

From this:

$$K_{eff}U_{prsv} \geq \frac{I_k}{Y_k} \quad (14)$$

Could define $\frac{I_k}{Y_k} = U_k^{avt}$, U_k is the autonomous breakdown voltage generated by the k - participant of the power supply system.

Autonomous breakdown voltage is a breakdown voltage in which the studied consumer can work separately from other participants of the power supply system.

Condition for fulfillment of inequality (9):

$$U_k^{avt} \leq K_{profit}U_{prsv} \quad (15)$$

The expression (15) makes it possible to clearly find out whether the influence of the k-th subject on the voltage disturbance at the common connection point is allowed. Let's consider two limiting cases:

If $I_k=0$ with non-zero transmittance (linear or symmetrical consumer), then $U_{kavt}=0$.

In this case, the condition (15) is always satisfied, and such a consumer will never cause an unacceptable voltage quality violation at a power grid node [3-6].

If $I_k=0$, with degraded current (disruptive consumer), then U_{kavt} tends to $\rightarrow+\infty$. Thus, according to (12), only a consumer with a quality-destroying load will always cause an unacceptable voltage quality violation at the common connection point. To fulfill the condition (15), such a consumer should increase its throughput Y_k by installing filters or compensating devices, thereby reducing U_k^{avt} .

In order to quantify the impact of the K-th consumer of power supply system on the voltage disturbance at the point of connection, it is proposed to introduce the concept of the influence coefficient:

$$K_{ta.k} = \frac{K_{eff}U_{prsv} - U_k^{avt}}{K_{eff}U_{prsv}} = 1 - \frac{U_k^{avt}}{K_{eff}U_{prsv}} \quad (16)$$

- The influence coefficient can take values from $-\infty$ to 1, including:

- if $K_{vl.k}$ is negative, then the k-th consumer has an unacceptable effect on the breakdown voltage at U_{poc} ;

- if $K_{vl.k}=0$, the k-th consumer in the power supply system $U_k^{avt} = K_{eff}U_{prsv}$;

- if $K_{vl.k}$ is positive, then the k-member of the power supply system has a positive effect on U_{poc} .

4 Conclusion

Summarizing the above research work on assessing the impact of consumers on the deterioration of the power quality through the use of equivalent circuits in the power supply system, can conclude the following:

- it is shown that the distortion of voltage cannot be unambiguously divided between the participants of the energy supply system;

- proportional to their influence, which confirms the incorrectness of the existing method noted in other works.

- the proposed method takes into account the features of existing approaches and regulatory documents, according to which each consumer must ensure the electromagnetic compatibility of their own electrical installations in terms of emissions of distortion currents into the external network.

- using the developed method, it is possible qualitatively and quantitatively assess the impact of each consumer on the emergence unacceptable voltage higher harmonic.

References

- GOST 32144-2013. Electric Energy. Standards for the quality of electrical energy in general-purpose power supply systems. <http://docs.cntd.ru/document/1200104301>
- Fedosov D.S. Razrabotka metoda ozenki vliyaniya potrebiteley na nesinusoidalnost b nesimetriyu napryajeniy v elektricheskoy seti. Dissertation, Irkutsk, 2014.
- Bobojanov, M.K., Mahmutkhonov S.K and others. AIP Conference Proceedings **2552**. (2023). 05011. <https://doi.org/10.1063/5.0113890>.
- M.K.Bobojanov, S.Mahmutkhonov, and S.Aytbaev. AIP Conference Proceedings **2552**. 050011. (2023). <https://doi.org/10.1063/5.0113890>
- Mahmutkhonov S.K, Kuuatbaev P.K. Analysis of load curves for DSP -100 furnace. Scientific and Theoretical Journal ISSN 2541-7789 (Online) **№4** (73), 2022. PP. 15-19.
- M.K.Bobojanov, O.E.Ziyodulla, and others. E3S Web of Conferences **177**. 03023. (2020). <https://doi.org/10.1051/e3sconf/202017703023>
- Mahmutkhonov S.K. Effect of non-linear consumers on the quality of electricity. Actual

problems of the power supply system // Proceedings of the international scientific and technical conference. - Tashkent. Tashkent State Technical University, 2021. PP. 267.

8. R Karimov. AIP Conference Proceedings **2552**. 030014. (2022). <https://doi.org/10.1063/5.0111533>

9. R Karimov, AIP Conference Proceedings **2552**. 050012. (2022). <https://doi.org/10.1063/5.0111524>

10. S Dzhuraev, R Karimov and others, Study and Analysis of Power Quality in the Electrical Networks of the Outdoor Lighting of the Dushanbe City (2022 Conference of Russian Young Researchers in Electrical and Electronic Engineering (ElConRus), 2022), pp. 1166-1169,
<https://doi:10.1109/ElConRus54750.2022.9755782>

11. R Karimov, A. Kuchkarov and others, Analysis and study of energy efficiency by the operation of a voltage stabilizer (Journal of Physics: Conference Series 2094, 052050, 2021).

<https://doi:10.1088/1742-6596/2094/5/052050>

12. M.Bobojanov. AIP Conference Proceedings **2552**. 050034. (2023). <https://doi.org/10.1063/5.0114077>

13. M.K.Bobojanov, R.Ch.Karimov, T.H.Qosimov, S.D.Zh.Dzhuraev. E3S Web of Conferences **289**. 07012. (2021).

<https://doi.org/10.1051/e3sconf/202128907012>

14. M.Bobojanov, D.Rismuxamedov, F.Tuychiev, K.Shamsutdinov, K.Magdiev. E3S Web of Conferences **216**. 01164. (2020).

<https://doi.org/10.1051/e3sconf/202021601164>

15. R.Karimov, M.Bobojanov. E3S Web of Conferences **216**. 01162. (2020).

<https://doi.org/10.1051/e3sconf/202021601162>