

Efficient protection and control of electric drives using solid state circuits

Erkin Abduraimov*

Tashkent State Technical University named after Islam Karimov, 100095, Uzbekistan, Tashkent, University St. 2A

Abstract. The paper presents the results of a theoretical study of semiconductor circuits carried out for practical use in the development of a non-contact switching and control apparatus for starting control and under voltage protection of AC motors. According to the results of the analysis of semiconductor circuits, it is recommended to use them when creating relay devices for the automation of electrical equipment. Theoretical investigated semiconductor circuits were used in the creation of a non-contact starter of an asynchronous electric drive with protection against operation at minimal voltage drops in the network.

1 Introduction

The problem of creating reliable and economical start-protective and switching devices and devices as elements of electrical equipment for AC circuits is of great importance for ensuring the uninterrupted operation, clarity and speed of operation of electric drives and other energy devices. They especially have the prospect of using semiconductor contactless switching and control devices in difficult climatic conditions, in various industries, in the field of automatic control of electric drives and in power supply systems.

As it is well known, with a decrease in the supply voltage of asynchronous motors, the level of magnetic flux decreases the torque consequently. This increases the current consumption, leading to a decrease in the voltage level in the power grid, which affects the operation of other devices connected to it. In addition, one should not forget about the starting currents generated when starting the motors. Spontaneous start-up, which occurs when the voltage is restored after its disappearance or when the general switch of the main line machine is turned on, etc., for the engines of most mechanisms of industrial enterprises is unacceptable due to the safety of the operating personnel, due to the danger of the mechanism breaking, due to possible product defects and in a number of ways other reasons. Therefore, with a significant decrease in the voltage in the network or its disappearance, the motors, as a rule, should be automatically switched off by special under voltage protection [1-8].

Currently, under voltage protection in motor control circuits is carried out by line contactors and electromagnetic starters or special under voltage relays. Which carry out the inclusion of the machine at a network voltage of at least 80% of the nominal and

automatically turn off the machine when the voltage disappears or drops to 50% of the nominal [9-15].

2 Theoretical researches

To start and protect AC motors from under voltage, we propose a circuit of a non-contact semiconductor device for controlling an asynchronous motor, which have been studied by theoretical and experimental studies. Theoretical studies of the components of the proposed device, the following circuits were considered, shown in Figures 1 and 2. [15-20]

Figure 1.a) shows a diode thyristor circuit, where a relay effect is revealed, with the help of which it is proposed to start and protect against under voltage in the control circuits of asynchronous motors. The explanation of the phenomenon of the relay effect can be carried out using the example of a diode-thyristor circuit, when the thyristor VT is connected in series to the network through R_u active resistance, and the control circuit is supplied with current from the network through the active resistance R and the diode VD (Fig. 1, a) [1-5].

If you slowly increase the input voltage, then at a certain value of U_{ax} , the amplitude value of the control signal will be equal to the thyristor opening current, at this moment the thyristor VT opens abruptly at an angle $\alpha=90^\circ$ (Fig. 1.b). A further increase in voltage leads to a decrease in the angle α almost to zero, i.e. the thyristor will pass a full positive half-wave of current. The voltage value at which the thyristor opens abruptly depends on the value of the parameters R and R_L . Thus, the opening of a thyristor with a jump or the phenomenon of a sharp change in voltage or current on the load in the considered circuit can be called a trigger or otherwise a relay effect [15-20].

* Corresponding author: abduraimoverkin69@gmail.com

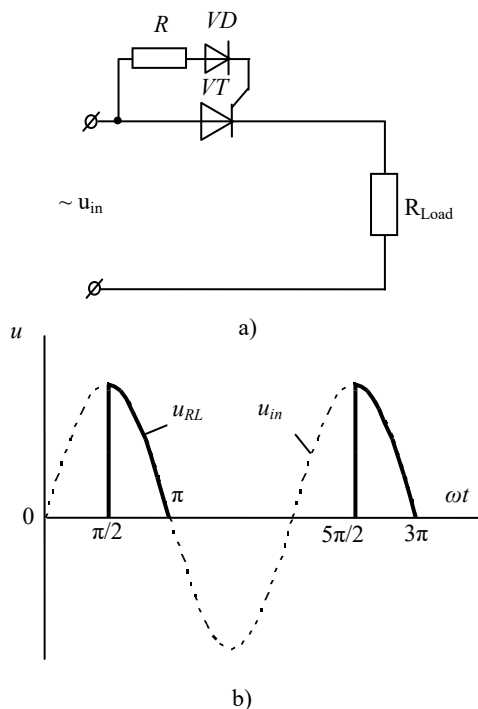

Fig.1. a) Thyristor switching circuit b) Mains voltage and load waveforms

Also, the mode of operation of a circuit consisting of a series-connected thyristor, active resistance and an inductive coil is considered, knowing that the windings of electric motors have an active-inductive nature of the load, and we take into account operation at mains voltages (Fig. 2).

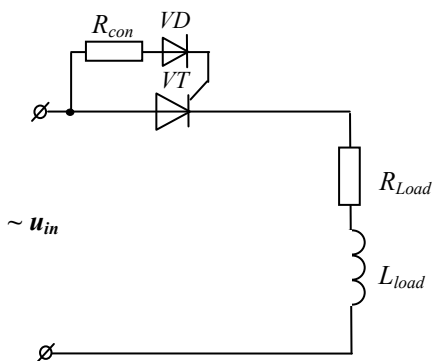

Fig.2. Circuit under study

The equation for this circuit has the following form:

$$u_{in} = u_{thy} + L \frac{di}{dt} + Ri$$

We accept the characteristic of the thyristor as ideal for the open state of the thyristor, while equation will take the form:

$$u_{in} = L \frac{di}{dt} + Ri = U_m \sin(\omega t + \varphi)$$

for

$$\varphi = \frac{\pi}{2}$$

$$L \frac{di}{dt} + Ri = U_m \cos \omega t$$

or

$$\frac{di}{dt} = \frac{U_m \cos \omega t}{L} - \frac{Ri}{L}$$

For different values of t , given the integration step h , we have:

$$i_n = i_{n-1} + \left(\frac{U_m \cos \omega t_{n-1}}{L} - \frac{R}{L} i_{n-1} \right) h$$

Figure 3 shows the voltage and current curves at the terminals of the elements L and R , constructed by solving equation numerical method. As can be seen from this figure, the current gradually increases and the moment of current termination is delayed relative to the moment when the phase voltage passes through zero. It should be noted that the shape of the current curve depends on the ratio of the circuit parameters L and R . The proposed technique allows a qualitative analysis of the steady-state modes and transient processes of the circuit with various variations of the parameters.

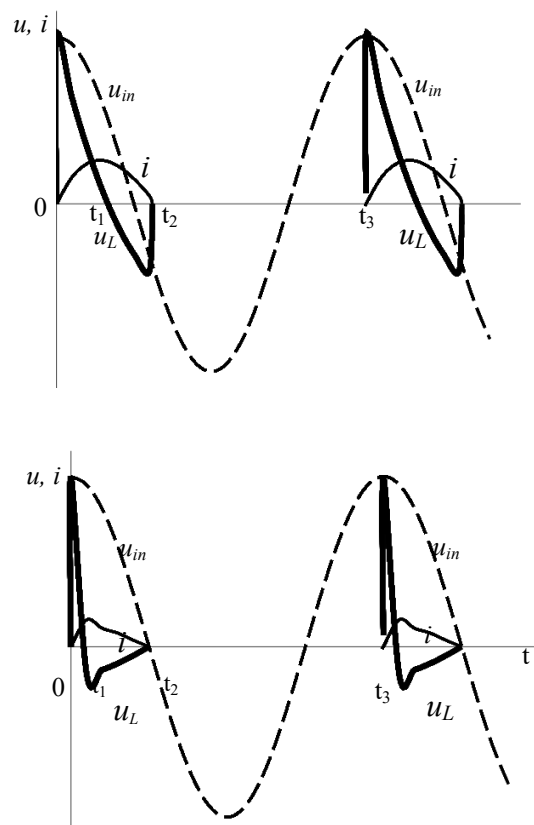

Fig.3. Curves of current and voltage at various values of resistance

Using these investigated circuits, on their basis, a non-contact device was developed to start and protect against the operation of the minimum voltage of AC electric motors, an asynchronous electric drive circuit

was proposed (Figure 4). Considering the frequent modes of starting electric motors and operating at low network voltages, a circuit of a non-contact three-phase thyristor starter of an asynchronous electric motor is proposed, consisting of six thyristors, six diodes and resistors, one small-sized intermediate relay and a circuit breaker [21-26].

3 Experimental researches

The engine is started by pressing the SB2 button and energizing the KL relay. At the same time, when the relay KL is activated, it closes its contacts, thereby signals are sent to the control electrodes of the thyristors through the resistor-diode circuit from the anode part of the thyristors themselves. The opening of the thyristors leads to the supply of mains voltage to the motor, and it starts. During operation, if the nominal value of the mains voltage decreases from the allowable value, then the currents in the control circuit of the thyristors, which are supplied from the anode part through the resistor and the diode of the thyristors themselves, also decrease, and this will lead to the closing or disconnection of all thyristors, and, accordingly, to disconnecting the motor from the mains.

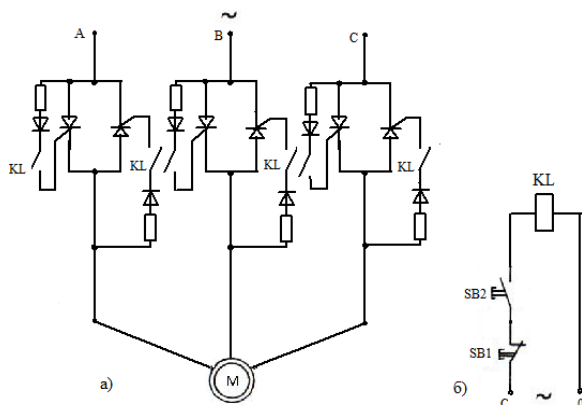

Fig. 4. Contactless thyristor induction motor starter with proposed under voltage protection circuit: a) - power circuit b) - control circuit

The engine is started by pressing the SB2 button and energizing the KL relay. At the same time, when the relay KL is activated, it closes its contacts, thereby signals are sent to the control electrodes of the thyristors through the resistor-diode circuit from the anode part of the thyristors themselves. The opening of the thyristors leads to the supply of mains voltage to the motor, and it starts. During operation, if the nominal value of the mains voltage decreases from the allowable value, then the currents in the control circuit of the thyristors, which are supplied from the anode part through the resistor and the diode of the thyristors themselves, also decrease, and this will lead to the closing or disconnection of all thyristors, and, accordingly, to disconnecting the motor from the mains.

Experimental studies of the starting mode of the electric motor and the curves of the change in current and voltage of the non-contact relay starter are shown in

Fig.5. for one phase. From these graphs it can be seen that the value of the starting current of the rated value is set in two periods and reaches a stable operating mode at permissible values of current and time.

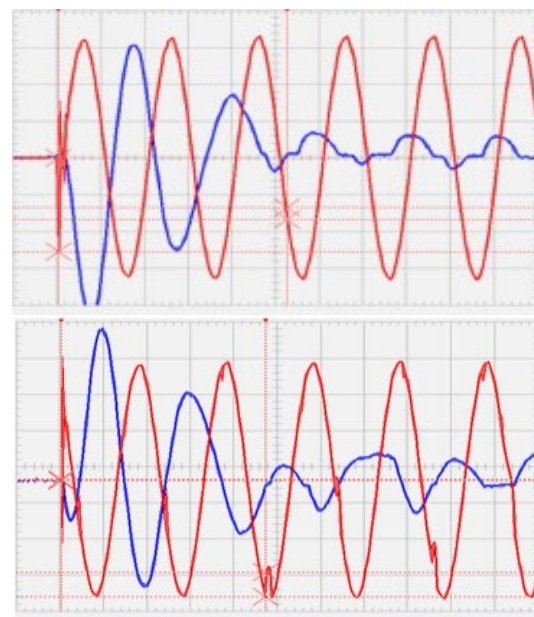

Fig.5. Oscillograms of current and voltage in one phase at the input and output of the starter when starting an asynchronous motor.

4 Conclusions

Thus, when analyzing the first semiconductor circuit, the opening of a thyristor by a jump or the phenomenon of a sharp change in voltage or current on the load can be called a relay effect and it is used in the creation of the device.

In the following circuit of a connected thyristor, active resistance and inductive coil, the operation of the circuit for an active-inductive load was analyzed, taking into account the nature of the load of the winding of electric motors, a numerical method was used for the analysis, it allows for a qualitative analysis of steady modes and transients.

In the proposed scheme for starting and controlling the protection of an asynchronous electric motor, due to the phenomenon of the relay effect observed on diode-thyristor circuits, it is possible to effectively control the smooth start and at the same time protect the electric motor from operating at low mains voltages, that is, from the minimum voltage.

References

1. E.Abduraimov, M.Peysenov, N.Tairova. AIP Conference Proceedings, 2552, **040012**, (2022), <https://doi.org/10.1063/5.0116235>
2. E.Kh.Abduraimov, D.Kh.Khalmanov. Journal of Physics: Conference Series, 2094(2), **022072**, (2021), [DOI 10.1088/1742-6596/2094/2/022072](https://doi.org/10.1088/1742-6596/2094/2/022072)

3. E.Kh.Abduraimov, D.Kh.Khalmanov, and others. E3S Web of Conferences, 289, **07026**, (2021), <https://doi.org/10.1051/e3sconf/202128907026>
4. E.Kh.Abduraimov, D.Kh.Khalmanov. E3S Web of Conferences, 216, **01106**, (2020), <https://doi.org/10.1051/e3sconf/202021601106>
5. E.Kh.Abduraimov. E3S Web of Conferences, 216, **01105**, (2020), <https://doi.org/10.1051/e3sconf/202021601105>
6. E.Kh.Abduraimov, D.Kh.Khalmanov. Journal of Physics: Conference Series, 1515(2), **022055**, (2020), [DOI 10.1088/1742-6596/1515/2/022055](https://doi.org/10.1088/1742-6596/1515/2/022055)
7. E.Kh.Abduraimov. Journal of Physics: Conference Series, 072009, **2373**, (2022), [DOI 10.1088/1742-6596/2373/7/072009](https://doi.org/10.1088/1742-6596/2373/7/072009)
8. E.Kh.Abduraimov, D.Kh.Khalmanov. Journal of Physics: Conference Series, 072010, **2373**, (2022), [DOI 10.1088/1742-6596/2373/7/072010](https://doi.org/10.1088/1742-6596/2373/7/072010)
9. R.Karimov. AIP Conference Proceedings, 2552, **030014**, (2022), <https://doi.org/10.1063/5.0111533>
10. R.Karimov. AIP Conference Proceedings, 2552, **050012**, (2022), <https://doi.org/10.1063/5.0111524>
11. S.Dzhuraev, R.Karimov, and others. ElConRus, (2022), pp. 1166-1169, [doi: 10.1109/ElConRus54750.2022.9755782](https://doi.org/10.1109/ElConRus54750.2022.9755782)
12. R.Karimov, A. Kuchkarov, and others. Journal of Physics: Conference Series 2094, **052050**, (2021). [doi:10.1088/1742-6596/2094/5/052050](https://doi.org/10.1088/1742-6596/2094/5/052050)
13. R.Karimov, N.Kurbanova, and others. Journal of Physics: Conference Series 2094(5), **052042**, (2021). [doi:10.1088/1742-6596/2094/5/052042](https://doi.org/10.1088/1742-6596/2094/5/052042)
14. K.G.Abidov, O.O.Zaripov, and others. AIP Conference Proceedings, 2552, **030023**, (2022), <https://doi.org/10.1063/5.0112385>
15. K.G.Abidov, O.O.Zaripov, and others. AIP Conference Proceedings, 2552, **030022**, (2022), <https://doi.org/10.1063/5.0112384>
16. K.G.Abidov, O.O.Zaripov, and others. E3S Web of Conferences, 289, **07003**, (2021), <https://doi.org/10.1051/e3sconf/202128907003>
17. K.G.Abidov, and others. E3S Web of Conferences, 289, **07004**, (2021), <https://doi.org/10.1051/e3sconf/202128907004>
18. K.Abidov, N.Khamudkhanova. E3S Web of Conferences, 216, **01111**, (2020), <https://doi.org/10.1051/e3sconf/202021601111>
19. K.G.Abidov, O.O.Zaripov, and others. E3S Web of Conferences, 216, **01110**, (2020), <https://doi.org/10.1051/e3sconf/202021601111>
20. K.G.Abidov, O.O.Zaripov. E3S Web of Conferences, 139, **01088**, (2019), <https://doi.org/10.1051/e3sconf/201913901088>
21. A.A.Khashimov, K.G.Abidov. Elektrotehnika, **7**, pp. 34-38, (2001).
22. A.A.Khashimov, K.G.Abidov. Elektrotehnika, **10**, pp. 22-26, (2001).
23. K.G.Abidov, A.K.Nuraliev, and others. Journal of Advanced Research in Dynamical and Control Systems, **12(7)**, pp. 2167-2171, (2020).
24. A.K.Nuraliev, and others. E3S Web of Conferences, 216, **01108**, (2020), <https://doi.org/10.1051/e3sconf/202021601108>
25. M.Ibadullaev, A.Nuraliev, A.Esenbekov. IOP Conference Series: Materials Science and Engineering, 862(6), **062031**, (2020), [DOI 10.1088/1757-899X/862/6/062031](https://doi.org/10.1088/1757-899X/862/6/062031)
26. S.Begmatov, D.Khalmanov, and others. AIP Conference Proceedings, 2552, **040011**, (2022), <https://doi.org/10.1063/5.0130666>