

Research on dynamic behavior vibration control of semi-submersible Marine platform based on ARID control system

Chengbo Luo

Shanghai Jiguang Polytechnic College, Shanghai, China

Abstract—As the development and infrastructure of deepwater oil and gas resources, the performance of the deepwater offshore platform is directly related to personnel safety, equipment safety, normal production and drilling process. Therefore, hydrodynamic calculation^[1] and flow response-based control and optimization are current hot research topics. Semi-submersible marine platforms are widely used in the industry due to their large deck area, strong wind and wave resistance, and excellent mining ability. However, their complex and diverse lines in the marine environment result in a series of dynamic responses due to wave loads, particularly in the rotating dynamic behavior, which cannot be efficiently controlled using traditional vibration control methods. Many research studies have focused on developing efficient control systems to suppress the dynamic behavior of semi-submersible marine platforms. For instance, active mass dampers (AMD) and tuning rotational inertia dampers (TRID) devices have been used to control the translation dynamic behavior of the platform. However, their performance in controlling the rotating dynamic behavior of the platform is unsatisfactory. To address this challenge, this paper proposes a new type of active control system called the Active Rotary Inertia Driver (ARID), which utilizes an active torque control system to suppress the rotating dynamic behavior of the semi-submersible marine platform. The ARID system is developed based on AMD and TRID devices and aims to enhance personnel and equipment safety, as well as the normal production and drilling process of the platform. Therefore, this study presents a comprehensive review of the research status on hydrodynamic calculation and flow response-based control and optimization of deepwater offshore platforms, particularly the semi-submersible marine platform. The proposed ARID system is expected to contribute to this research area by offering an efficient solution to the rotating dynamic behavior of the platform.

1. Introduction

According to incomplete statistics, for land, the only oil and gas reserves available are 30-80 years. With increasing human desires and the inevitable consumption of oil and gas, experts predict that in the 21st century, there will be less and less oil on earth, until very short. However, there are still a large number of natural resources in the ocean that have not been exploited and adopted by human beings. Most of the oil and gas on earth is in the ocean, which accounts for 35 percent of the entire earth. So far, we have only found 30%, which means that there is still a lot of this energy in the ocean that has not been exploited and utilized, and this amount is undoubtedly very attractive to all mankind.

As the offshore infrastructure, the Marine platform has the role of carrying people's daily life, daily production and other aspects. In order to ensure the vibration of the platform itself and the safety of personnel and equipment safety, we must pay attention to the control effect of various loads, which is particularly important. Due to the complexity of the working environment, the Marine platform has been working in the relatively harsh Marine environment for a long time, mainly affected by various loads such as wind, wave and flow, which will produce

obvious vibration effect on the Marine platform. For an ocean platform, most of the pressure it puts under, and the waves put under is outside of the platform. Therefore, it is necessary to analyze the vibrational response of the ocean platform under the influence of wave pressure.

2. Overview of the marine platform

2.1 Introduction to the development of the semi-latent platform

At present, according to the different ways of platform movement^[2], Marine platforms can be divided into two kinds, one is mobile, the other is stable, while mobile is divided into floating type, sitting bottom type and compliant type, among which, semi-submersible type belongs to one kind of floating platform.

Compared with other types of Marine platforms, the semi-submersible Marine platform has the advantages of wind resistance, wave resistance and good sports performance. At the same time, the semi-submersible Marine platform has large deck area and strong bearing capacity, and has functions such as local drilling, workover and production. These advantages are unmatched by other platforms in high-seas energy

e-mail: 3985894@qq.com

production. There is no doubt that semi-submersible Marine platforms are highly competitive and are widely used in offshore engineering operations and offshore oil and gas resource exploration.

In 1897, the first offshore platform was built in California^[3]; in 1911, the first real ocean platform between Louisiana and Corxas; and the peak of two rounds in the mid-late 1970s and early 1980s.

The semi-submersible Marine platform^[4] evolved from the bottom drilling platform, the first semi-submersible Marine platform "Blue Water Rig No.1" was

founded in 1961, after more than 50 years of development and application, it has progressed to the sixth generation, from form to function, such as increasing the depth of drilling, the expansion of operating water and so on. The latest platform greatly increases the workload, adapts to worse waters, increases the bearing capacity of variable loads, and makes for a simpler shape and structure. Various semi-submersible Marine platforms with different levels of technology have their own characteristics as shown in the table.

Table 1 Main characteristics of semi-latent platforms with different technical levels

technical level	Work depth / meter	Drilling capacity / ft	location mode	Main construction age	remarks
first generation	90~180	-	anchor moored positioning	The 1960s	
second generation	180~600	10000~15000	anchor moored positioning	The 1970s	
third generation	50~1500	15000	anchor moored positioning	From 1980 to 1985	
The fourth generation	1000~2000	15000~30000	anchor moored positioning	1985~1990	1988-2001
The fifth generation	1800~3600	25000~37500	dynamic positioning	From 2000~2005	Adapt to worse Marine conditions
The sixth generation	2550~3600	≥30000	dynamic positioning	After 2007	Adapt to very harsh marine conditions

2.2 Introduction of semi-submersible platform structure

The semi-submersible marine platform is also called a column stable drilling platform. Many parts of it is in water, which belongs to a mobile drilling rig with a small waterline area. There are special structures to connect the lower body and the lower body, the column and the column, the column and the platform body. For the following structure, the connection points are mostly above it, and then, when the platform has unknown changes, it can be placed above the waterline to reduce the resistance; the platform is also specially equipped with drilling facilities, living places, etc., which can be used while drilling. The platform usually goes over the water, so that the waves have no effect on it. The lower body or tank in the water is the main dependence of buoyancy, which can also reduce the impact of the waves on the structure. The lower structure is divided into two types of lower hull type^[5] and floating tank type. Because the lower hull type navigation is more convenient, so most of the

current self-navigation semi-submersible Marine platform are double lower hull type. In order to ensure that the platform is more stable, it is necessary to ensure a certain interval between the two main columns. Such a platform is mostly in a semi-grain state, and the position is determined by anchorage or by power. After use, get the water in the ballast compartment out to the waterline. It is usually used at 60 to 3,050 meters underwater, though with more advanced technology, it can use more depth.

2.3 Basic dynamic behavior of the semi-submersible Marine platform

With the increasing working intensity of Marine platforms and the deteriorating of working environment under extreme load conditions, a series of complex dynamic behaviors will occur in Marine platforms. If the deformation of the ocean platform itself is ignored, that is, assuming that the structure is rigid, the center of gravity of the ocean platform is positioned as the origin, and the coordinate system as shown in the figure is established.

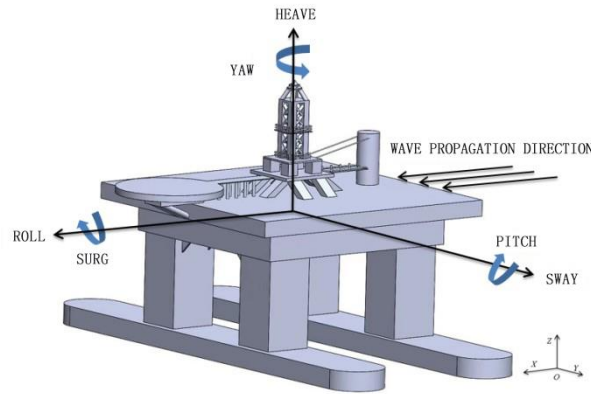

Fig. 2 Schematic diagram of the six dynamic behaviors of the semi-submersible Marine platforms

The six adverse dynamic behaviors of the Marine platform will cause violent vibration and displacement during the work of the platform, affecting people's work.

Thus, for these six dynamic behaviors of marine platforms, the dynamic behaviors is defined as shown in Figure 3 and Figure 4.

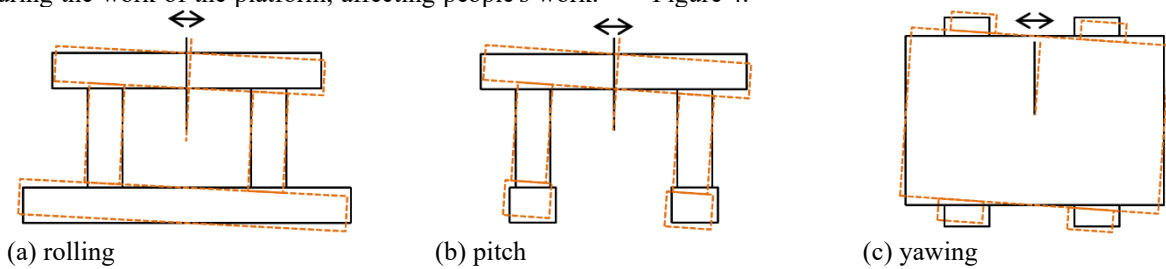

Fig.3 has a dynamic behavior with rotational components

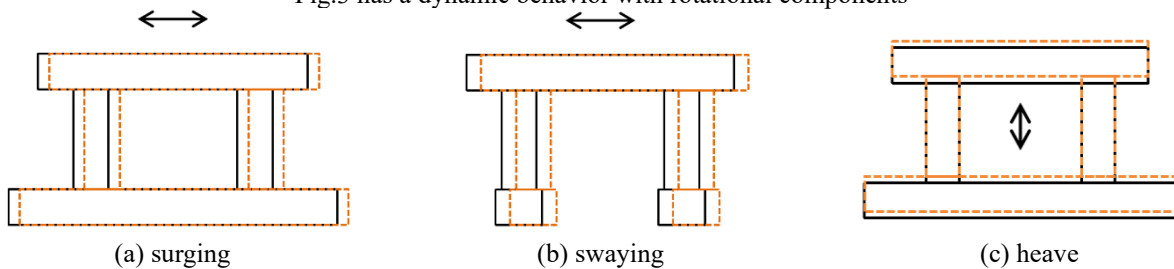

Fig.4 has a dynamic behavior with translational components

3. Dynamic behavior vibration control of semi-submersible Marine platform based on ARID control system

In view of the relevant content mentioned in the above article, there is still a lack of vibration control of the semi-submersible Marine platform under the condition of wave load. In order to effectively control the dynamic behavior of the semi-submersible Marine platform, the ARID active torque control method is proposed for effectively control: (1) Numerical simulation of wave load and simulation research under extreme working conditions.

The time domain sample of regular and irregular wave forces is obtained by wave theory, and then the longitudinal angle time course curve of the semi-submersible ocean platform under regular wave load and irregular wave load respectively. According to Haiwen

data, simulate the effectiveness of ARID active torque control system under extreme working conditions.

(2) Theoretical modeling of the semi-submersible marine platform under the action of the ARID active moment control system.

According to the ARID active torque control system proposed in this paper, the dynamic behavior of the semi-submersible Marine platform is simplified and directly applied to the structure of the semi-submersible Marine platform, which directly suppresses the dynamic behavior of the semi-submersible Marine platform by the generated control moment. Later, the dynamic analysis model of the semi-submersible ocean platform is established and the kinematic equation is derived. Solve the active control force based on LQR algorithm^[6], and finally analyze the effectiveness of ARID active torque control system from the perspective of control effect and system energy. The LQR controller can be obtained through Riccati

differential equations (as shown in Figure 5 and Figure 6), which obtain the optimal control law of linear feedback

based on the state equations and performance indicators of the linear system, thereby obtaining the optimal control input.

$$y' = P(x)y^2 + Q(x)y + R(x)$$

Fig.5 Riccati differential equation

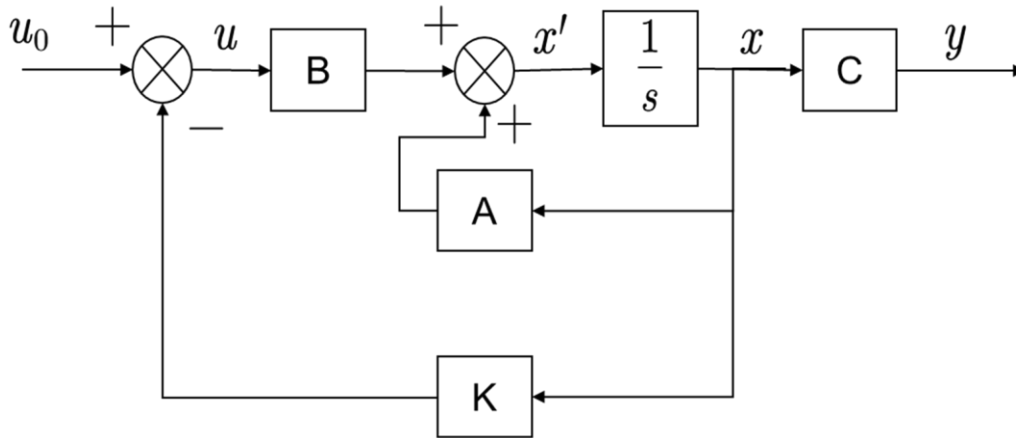

Fig.6 Principle block diagram

(3) Parameter analysis of ARID active torque control system based on semi-submersible Marine platform.

Based on the semi-submersible Marine platform ARID active torque control system, through the introduction of control effect evaluation index RMS and Peak, analytical control algorithm parameters, rotational inertia ratio, motor growth than the control effect, and thorough analysis of the system control parameters and control cost direct relationship, to find the optimal control interval of the control parameters.

(4) Performance verification of the ARID active torque control system of the semi-submersible Marine platform.

According to the scale ratio of 100:1, design a semi-submersible Marine platform ARID active torque control system model, the equipment and wiring, finally design the free attenuation, sine wave, seismic wave, sweep wave, wave under several different performance conditions, the ARID active torque control system to suppress the effectiveness of longitudinal rock dynamic behavior verification and analysis.

The research is mainly divided into two parts: simulation of the effectiveness and parameters of ARID active torque control system under wave load and performance test of ARID active torque control system for semi-submersible Marine platform. Firstly, based on the wave theory, the author calculates the irregular wave load with the Morison equation. Second, put forward ARID active torque control system of semi-submersible Marine platform shake the basic concept of dynamic behavior control, combined with the principle of active control, the semi-submersible Marine platform dynamic modeling and mechanical formula derivation, and according to the ARID active torque control system of semi-submersible Marine platform to verify the effectiveness and feasibility of dynamic behavior vibration control. Then, through dynamic modeling and formula derivation, Matlab program and Simulink modeling, the parameters of ARID active torque control system were studied, the parameters

of LQR active control force algorithm and the optimal value interval were determined, and the control effect and the control cost were analyzed. Finally, a small set of semi-submersible Marine platform test system was developed to design different working conditions, and the vibration platform test was conducted to verify the effectiveness of ARID active torque control system on the dynamic behavior of semi-submersible Marine platform.

4. Conclusion

In order to solve the problem of vibration control of the dynamic behavior of semi-submersible Marine platform, this paper puts forward the ARID active torque control system to effectively suppress the dynamic behavior of semi-submersible Marine platform, according to the semi-submersible Marine platform ARID active torque control system, and then the kinematic equation is derived. The proposed ARID active torque control system can directly act on the controlled structure, namely the semi-submersible ocean platform, to directly control its adverse dynamic behavior. The controller of the ARID active torque control system can monitor the adverse dynamic behavior of the semi-submersible Marine platform in real time, and control the output torque in real time through the LQR active control force control algorithm. The influence of ARID active torque control system on the control effect is deeply studied, the optimal value interval of various parameters is determined, and the control cost is reduced on the premise of ensuring the control effect, thus further proving the feasibility of ARID active torque control system. A set of small semi-submersible Marine platform-ARID active torque control system was developed for control tests under different working conditions, which showed extremely high control effect, and effectively verified the effectiveness and feasibility of ARID active torque control system.

References

1. J.P.Hooft, A Mathematical Method of Determining Hydrodynamic Induced Forces on a Semi-submersible, Transactions-Society of Naval Architects and Marine Engineers, 2019, 79: 18-70.
2. H.L. Minkenberg, M.F.V.Sluijs, Motion optimization of semi-submersibles, in OTC 1971.Dallas, Texas, 1971: 131-137.
3. P.W.Penney, Ma Guangchan, Yang Xiuju, Zhou Tianming, Zhang Peng, Li Yunpeng, Hu Nan, Wang Anyi. Research on the Integration Design of Double Well Head Drilling System for Semi-submersible Drilling Platform[J]. IOP Conference Series: Materials Science and Engineering, 2019,611.
4. K.Haslum, The motion performance and mooring system of deepwater semi-submersible drilling unit[J]. Journal of Marine Science and Application, 2020,8(3).
5. Birk L and Clauss GF. Automated hull optimisation of offshore structures based on rational sea keeping criteria[A]. Proceedings of the Eleventh (1001) International Offshore and Polar Engineering Conference[C]. Stavanger, Norway, 2001: 381-389.
6. S.Akagi, Wensheng Xiao, Lei Wu, Keke Wei, Congcong Xu, Chao Hou, Junguo Cui, Jie Li. Research on facility layout optimization algorithm of deep-water semi-submersible drilling platform[J]. Journal of Mechanical Science and Technology, 2019,33(2).