

# Microprocessor moisture measuring device of bulk materials based on the capacitance transformer with cylindrical electrodes

*T Nasirov*<sup>1,2,3\*</sup> and *Kh Jabborov*<sup>2</sup>

<sup>1</sup>University of Geological Sciences, Olimlar str., 49, 100041, Tashkent, Uzbekistan

<sup>2</sup>Tashkent State Technical University, Universitet str., 2, 100095, Tashkent, Uzbekistan

<sup>3</sup>Tashkent Branch of Moscow State University of Oil and Gas named after M.A. Gubkin, 100125, 34, Durmon yuli str., Tashkent, Uzbekistan

**Abstract.** The construction of a moisture transformer device consisting of four electrodes that allow increasing accuracy of moisture measurements of grain and grain products up to 0.5% has been proposed. The proposed device in the laboratory conditions has been tested in comparison to other known transformer types. The carried-out analysis of the experimental results showed that in all used transformers we observe the disperse growing of grain degrees when rain moisture is increasing. The results obtained for moisture less than 11 % are similar practically to each other. When the moisture is growing this similarity is breaking.

## 1 Introduction

The inductive-capacitance transformers in the current stabilization systems composition in the transformer and pulse technics, charge systems of capacitance drivers, batteries, energetic supply systems, electric drives, for power supply of electric devices, lasers, ignition systems, and light technics are used traditionally. The capacitance transformers widely in measuring devices also were practically used, especially for moisture-measuring products in the technological processes. At the same time, it is very important to have the devices having the sensitivity within measurement accuracy of the product's moisture up to 0.5% especially when we deal with technological processes that are in the dynamical working regime of production equipment's elements.

It is known that the transformer accuracy of a moisture meter with a cylindrical electrode depends on the constructive technological features of its constituent elements, their effective working possibilities, and also the linearity degree of static characteristics.

In paper [1] the material controllability placed to the first capacitance transformer had been investigated where the transformer capacitance was a measuring parameter. There the dielcometric method for moisture controlling had been described which at present is used widely in the food industry for raw cotton, cotton seed, husks, meal, cake, grain, and grain products moisture controlling.

---

\*Corresponding author: [tulkunnasirov@yandex.ru](mailto:tulkunnasirov@yandex.ru)

The microprocessor moisture measuring device for powder materials based on the capacitance transformer with cylindrical electrode for moisture measuring of powder materials including grain and grain products is intended. In its developing period, the elements having high accuracy of modern integral microelectronics had been used [2].

In paper [3] the calculation method for basic parameters of inductive capacitance transformers made based on two sections' structure of many functional integrated electromagnetic components working in the bridge inventor composition had been developed. There the expressions for inventor parameters, the LC circuit inductivity, and capacity calculating had been obtained and a calculation algorithm for inductive capacitance transformers parameters based on the many functional integrated electromagnetic component had been proposed which plays the role of the inventor oscillatory circuit (inductivity and capacity) when considering the chosen many functional integrated electromagnetic components structure.

The device working principle is based on the electric capacity and capacitor energy, material dielectric permeability variation at the moment when a material between electrodes is set for which measure the moisture is required. This variation by distribution on the material's length of the electric field flow strength is explained. This distribution leads to the material conductivity and resistance variation in result in an output of the capacitance transformer the signal depending on the input quantity – the moisture appearing [3].

In the present paper, we propose the measuring system scheme of the microprocessor device which allows an increase in the measurement accuracy of grain and grain product moisture by correlation of the environment temperature variation.

## 2 Materials and methods

The scheme of the microprocessor device which allows for increasing the measurement accuracy of grain and grain products moisture by correlation of the environment temperature variation has been presented in Figure 1. During its development, we used elements having high accuracy of integral microelectronics.

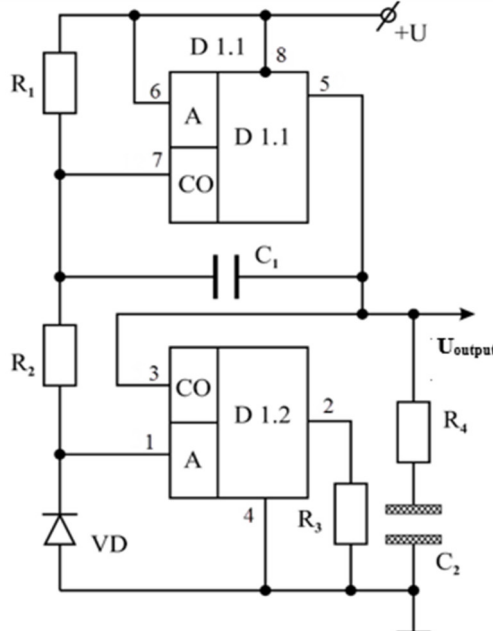

**Fig. 1.** The measuring generator scheme.

The moisture measuring generator with cylindrical electrodes collected on the scheme with an automatic electronic key contains the symmetric multi-vibrator because it consumes the essential small current (15 mA). Voltage served through voltage stabilizer (9 Volt). D1.1 and D1.2 elements in the scheme are the automatic electronic keys. When voltage is served, then these electronic keys will be in separate regimes. Because the charge is absent in the C1 capacitor, the voltage is absent too, and the current from the power supply will flow via consequently connected R1 and R2 resistors. Since  $R1 > R2$ , the voltage in the R2 resistor will be insufficient for connecting the D1.2 electronic key. Further, as a result of decreasing charging current, this voltage will tend to zero value.

Namely, at this moment the voltage in the capacitor in output 7 of the D1.1 electronic key is growing, and the charge is increasing exponentially. After reaching the concrete voltage up to the switch-on value of the D1.2 electronic key, gates 5 and 6 are connected. These connections switch on the D1.2 electronic key. After connections of electronic keys lower electrode Ct is connected with the positive power supply pole.

The charge collected in the capacitor cannot be changed instantly, and therefore the voltage in gate 7 of the D1.1 key change with a jump, so that its value will exceed the voltage value in the power supply. This will be enough for switching the D1.1 electronic key. After that, the voltage in the C1 capacitor will be decreasing with a time constant. This regime of the generator provides an appearance of stable pulse oscillations in its output. As a result of changing the moisture of the transformer with cylindrical electrode capacitor C2, the measuring signal in output 1 of the generator is formed. Since the measuring generator is one of the microcontroller constituent elements, it has one common connection point and provides a stable working regime.

The circuit scheme of the moisture measuring system detector based on the capacitance transformer with cylindrical electrode has been presented in Figure 2.

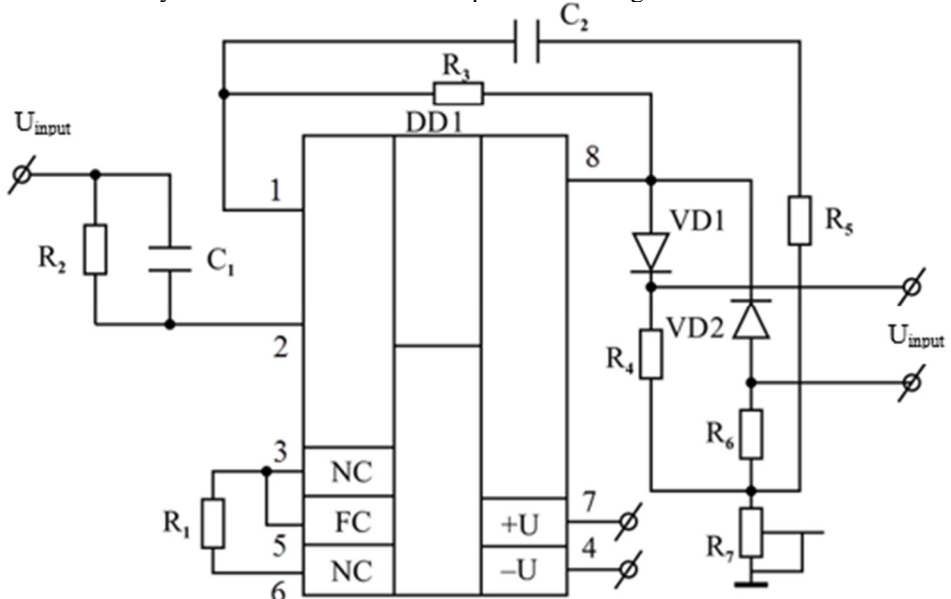

**Fig. 2.** The circuit of the moisture measuring system detector is based on the capacitance transformer with the cylindrical electrode.

In Figure 2, the DD1 detector, being one of the common elements of the moisture measuring system, based on the capacitance transformer, consisting of a cylindrical electrode, is collected the microscheme according to the rectifier circuit with 2 half periods.

Having the detecting possibility almost up to the input signal maximal value, this detector serves to straighten going from the measuring generator of variable pulse voltages to a DC voltage. Its sockets 7-4 we can connect DC voltage in the range of 5 and 9 Volts and a voltage stabilizer is formed.

Here the DC R3 resistor and on AC C2 capacitor provide 100% negative feedback, which connections provide a stable detector working regime. There are controlling possibilities by the detector sensitivity via the R7 resistor. As operative amplifier DD1 works in the integrated signals regime in the detector output, we obtain the average quadratic signals value. R2 resistor and C1 capacitor in the detector input defines the signal's integrated time.

It should be noted that resistors in the input and output of all devices constructing measurement system of the bulk material's moisture are identical, which provide the constancy of useful measuring signal in the range of total cycle. The identical task of input and output resistors is the best basic requirement of integral microelectronics.

As a result of material moisture changing located between cylindrical electrodes, its capacity is changed and in the output of the generator, corresponding to the moisture, the variable signal is formed [3]. After that this variable signal is transmitted to the detector, and one is straightened via half period circuit. In the detector output, the average quadratic value of the processed signal up to its maximal value is detected.

The detector load is the operative amplifier, which amplifies the signal, and after processing transfers it to the microcontroller AT type mega 8A. The microcontroller transforms the analog signal to the decoded digital one, and this system on the special program is working. The processed signal transfers to the light crystal indicator and on its display, the measured moisture value appears.

The appearance of the capacitance measuring device of grain and grain products is presented in Figure 3. The microprocessor measuring device based on the transformer with a cylindrical electrode intended for measuring grain and grain products moisture contains the measuring cell in a right quadrilateral shape. To the side walls of the vertical planes, 4 capacitance transformers with cylindrical electrodes are riveted.

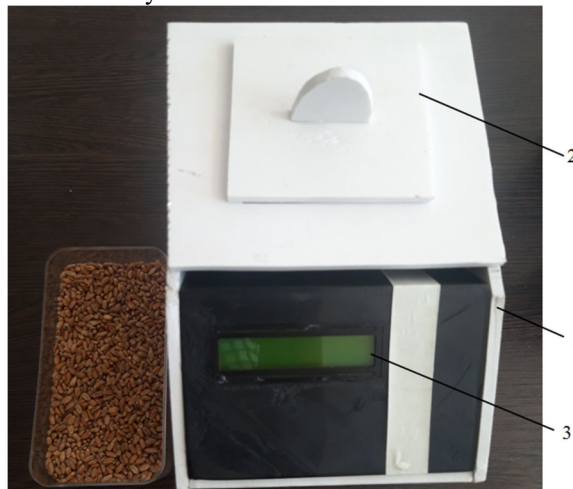

**Fig. 3.** The capacitance measuring device of grain and grain products: 1 is the frame, 2 is the lid, 3 is the light crystal indicator

The capacitance electrodes on the measurement cell's opposite side walls are connected mutually in a parallel arrangement and are established to the measuring generator oscillatory circuit. The measuring device's overall dimensions are  $20 \times 15 \times 13$  mm<sup>3</sup>, and the measuring transformer's single electrode sizes are  $10 \times 6$  mm<sup>3</sup>. For stabilization of the grain

product placed in the measuring cell, it is covered by a lid (no. 2 in Figure 3). The downside is movable and is attached to the device's backside with a clip, which can be moved on the perimeter by the measuring device cut rails.

Thus, this lid serves for releasing a cell from grain products after using the device for measurement. On the downside of the measuring device, there is a special carriage, which serves for reception of the grain products, which has measured already its moisture.

Being the basic feature of the moisture meter device, the capacitance cylindrical electrode provides the device readings, when the moisture of the controlling material passing through the first capacitance transformer is changed, at which time the measuring device readings are changed too. This ability is very important for moisture meters, which characterize the device's quality.

### 3 Results and discussion

In experiments, we tested the device reliability on that order.

- 5 grains samples with moisture in the range of 10% and 20% are prepared, which are distributed equally on the measuring range. The moisture degree for each sample we defined by the standard method (these values serve as samples for which the absolute error must be less than 0.5%).
- Each sample is poured into the first capacitance transformer of the moisture meter 10 times, and the device readings were registered in a working notebook.
- The moisture average value is defined.
- The moisture absolute errors are calculated.
- The relative error of moisture measurements is calculated using the expression:

$$\delta = \frac{|W_{av} - W_{meas}|}{W_{av}} \cdot 100 \% \tag{1}$$

Here  $W_{meas}$  and  $W_{av}$  are the moisture measurement values and its average value, correspondingly.

The measurement and calculation results for grain moisture obtained using the different transformers have been presented in table 1. Here  $\delta_{min}$  and  $\delta_{max}$  are the sample minimal and maximal relative errors, correspondingly,  $\delta_{av}$  is the average value of the relative error. The last 2 columns show the measurement quantity corresponding to the given error range (2 %).

**Table 1.** The statistical data for moisture measurement errors of grain using the different types of capacitance transformer.

Capacitance transformer with two electrodes (coaxial electrodes)					
W, %	$\delta_{min}$ , %	$\delta_{max}$ , %	$\delta_{av}$ , %	$\delta_{meas} < 2\%$	$\delta_{meas} > 2\%$
Up to 11 %	0.26	1.7	1.5	8	2
11 – 13 %	0.38	4.3	2.0	5	5
13 – 15 %	0.36	6.35	2.15	4	6
15 – 17 %	0.36	7.35	3.8	3	7
17 – 20 %	0.4	6.3	3.9	3	7
Infrared analyzer					
W, %	$\delta_{min}$ , %	$\delta_{max}$ , %	$\delta_{av}$ , %	$\delta_{meas} < 2\%$	$\delta_{meas} > 2\%$
Up to 11 %	0.8	3.1	1.4	6	4
11 – 13 %	1.0	4.12	2.1	5	5
13 – 15 %	1.7	7.1	2.4	3	7

15 – 17 %	1.6	6.8	2.5	4	6
17 – 20 %	1.5	6.3	3.5	4	7
Capacitance transformer with four electrodes					
W, %	$\delta_{\min}, \%$	$\delta_{\max}, \%$	$\delta_{av}, \%$	$\delta_{meas} < 2 \%$	$\delta_{meas} > 2 \%$
Up to 11 %	0.2	2.1	0.8	9	1
11 – 13 %	0.16	1.8	0.8	10	0
13 – 15 %	0.1	1.9	0.65	10	0
15 – 17 %	0.2	2.0	0.89	10	1
17 – 20 %	0.3	2.2	1.0	8	2

As seen from the table, the obtained results for the four electrodes transformer are very close to true values. The reason for this similarity, in our opinion, is that when the number of electrodes is increased, the wet grain distribution is normalized, and therefore we can observe an increase in the transformer sensitivity.

## 4 Conclusions

The carried-out analysis of the experiment showed that in all used transformers we observe the disperse growing of grain degrees when rain moisture is increasing. The results obtained for moisture less than 11% are similar practically to each other. When the moisture is growing, this similarity is breaking.

## Acknowledgment

Investigations were carried out with financial support from Uzbekistan-Belarus grant IL-432105684.

## References

1. P. Kalandarov, Z. Mukimov, X. Abdullayev, N. Avezov, *The mathematical and empiric base for moisture measurement of solid and bulk materials*, *Matematicheskoye i programnoye obespecheniye v promishlenni i sosialnoi sferax*, **9**, 1, 16-21 (2021)
2. A. Bauer, *The capacitance measuring transformer, system and preparation method of capacitance measuring transformer*, Patent RU 2658150 C2 19.06.2018. 17. (2018)
3. S. Konesev, R. Xaziyeva, *The calculation methodics for inductive capacitance transformers based on the many functional integrated electromagnetic components*, *J. Vestnik UGATU* **22** **1** (79), pp. 97–105 (2018)