

# Wheeled tractor equipped with a mechanism for changing the ground clearance

*Adilbek Akhmetov*<sup>1\*</sup>, *Ravshan Botirov*<sup>1</sup>, *Mansur Amonov*<sup>1</sup>

<sup>1</sup>“Tashkent Institute of Irrigation and Agricultural Mechanization Engineers” National Research University, 39 Str.K.Niyazov, 100000 Tashkent, Uzbekistan

**Abstract.** In accordance with the agricultural row-crops cultivation practices adopted in the Central Asian region, machine-tractor units carry out a large number of passes through the field during the growing season. Consequently, individual sections of the fields are repeatedly affected by the running systems of these machines, which negatively affects soil fertility. The universal row-crop tractors used in cotton production have two types of wheel arrangements: 3W2 and 4W2. Consequently, these arrangements have different natures and magnitude of impact on the soil. Despite a number of advantages of 4-wheeled tractors due to insufficient agrotechnical clearance under the front and rear axles beam, they are not used for inter-row cotton cultivation. Mechanisms including a stepless change in ground clearance, both for the front and rear axles of a 4-wheeled tractor, eliminate these disadvantages and thereby expand the possibilities of their use. The use of a 4-wheeled tractor in field and transport operations has shown that the most loaded parts in the developed mechanism for changing the clearance of the rear axle are rolling supports of the cage on the casing of the rear axle of the tractor.

## 1 Introduction

Uses of off-road vehicles, including tractors and other agricultural machines, have a significant impact on the agrophysical properties of the soil [1-3]. This dependence is clearly expressed in those areas where the cultivation of agricultural crops requires multiple passes of mobile agricultural machinery through the field [4]. For example, in accordance with the cotton cultivation technology adopted in the Central Asian region, aisles are cultivated (3-5 times), and furrows are cut for irrigation, spraying against pests and diseases [5, 21], to prepare for harvesting a ripe crop, defoliation and sometimes desiccation of cotton are carried out, followed by machine harvesting of the raw cotton [6].

As seen from the above, during the season, machine-tractor units carry out a large number of passes, and individual sections of the field are repeatedly affected by the wheels of the machines. At the same time, the more traces of the tractor wheels, the greater area of soil exposed to negative impacts [7,8].

Agricultural tractors, play a major role in mechanization and they have various types and configurations of running systems [9,10]. For example, in cotton production, universal

---

\* Corresponding author: [tractor-v@mail.ru](mailto:tractor-v@mail.ru)

row-crop tractors of the TTZ brand with a traction class of 1.4 kN are used, they have different wheel arrangements (Figure 1), 3W2, and 4W2 [11, 12]. Consequently, the nature and magnitude of the impacts of these machines on the soil are different [13].



**Fig. 1.** Universal-tiller tractors with 3W2 (a) and 4W2 (b) wheel arrangements.

Numerous studies have shown that over compaction of soils as a result of the impact of the running systems of tractors and other mobile machines causes deterioration of the agrophysical properties of soils, with a decrease in their fertility and the yield of crops cultivated in these fields [7, 8].

The results of the impact of the running systems of mobile agricultural machinery on the density and fertility of soils were revealed in the works of Nikolayev V.A. [1], Astafieva V.L. [2], Zabrodsky V.M. [3], Rusinov A.V. [4], Rusanov V.A. [7], Slyusarenko V.V. [8], Bondarev A.G. [14], Vodyanik I.I. [15], Zolotarevskaya D.I. [16] and other scientists.

However, these works were carried out first in the soil and climatic conditions of European countries and second in various brands of tractors other than those used in cotton production. As already mentioned, in cotton production, the same tractors are used but with a different wheel arrangement.

Reducing the maximum pressure of the wheels on the soil and a more rational distribution of machine-tractor units' masses along the axles is an incomplete list of the advantages of 4-wheeled tractors over 3-wheeled tractors [17]. However, due to insufficient agrotechnical clearance under the front and rear axle beam, these tractors are not used for inter-row cotton cultivation. The stepless adjustment of the tractor clearance from low to high positions would expand the using range of 4-wheeled tractors in inter-row cotton cultivation.

The Design and Technological Center of Agricultural Machinery LLC (DTCAM) is developing a mechanism for changing the clearance of the rear axle (Figure 2), which makes it possible to change the agrotechnical clearance of the tractor from 600 to 870 mm [18, 19, 22].

The mechanism for continuously changing the clearance of the rear axle of the tractor consists of cage 6, held by two needle bearings 13 on the sleeve 10 of the shaft 1 of the rear axle to the end flange 5 of the cage; the body 3 of the additional final drive is fixed with fastener 4. A fixing flange 12 with two opposite grooves for fastening elements 11 are made on the side of the cage neck opposite to the place of attachment of the additional final drive housing. In this case, the grooves on the fixing flange are made so that in the two extreme positions of the fastening elements in them, the tractor takes a high clearance or low clearance position. The fixing flange itself, by means of fasteners, is fixed to a bracket 9 for hanging devices and fixed to the sleeve 10 of the shaft 1 of the rear axle.

On the middle part of the cage, lever 7 is pivotally connected to rod 8 of the hydraulic cylinder by means of a pin. The hydraulic cylinder itself is equipped with a hydraulic lock and is fixed by means of a bracket and a spacer to the tractor frame.

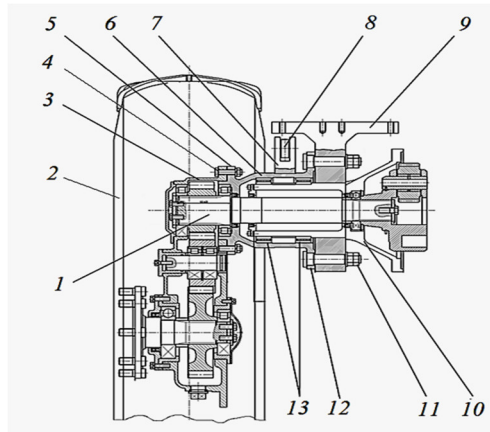

**Fig. 2.** A mechanism for changing the clearance of the rear axle of the tractor, rear view: 1 - semi-axle; 2 - driving wheel; 3 - a body of additional final drive; 4, 11 - fasteners; 5 - end flange; 6 - clip; 7 - lever; 8 - hydraulic cylinder rod; 9 - suspension bracket for hanging devices; 10 - semi-axle sleeves; 12 - fixing flange; 13 - needle bearings

The mechanism for changing the clearance of the rear axle of a tractor with a lever drive works as follows.

If it is necessary to transfer the tractor to a high-clearance version, the operator slightly unscrews the fasteners 11 and makes sure that holder 6 rotates easily. Then, it gives a command to move to the outside of rod 8 of the hydraulic cylinder, which in turn, by means of lever 7, turns the cage, and with it, turns the additional final gear attached to it, moving it into a vertical position. With this position of the final gear, the agrotechnical clearance increases from 600 to 870 mm, and the tractor can be considered a high-ground clearance machine.

To transfer the tractor from a high-clearance to a low-clearance position, the operator gives a command to retract the hydraulic cylinder rod 8 into the inner side of the hydraulic cylinder, which in turn, by means of a lever 7, turns a clip 6, and together with it turns the additional final gear fixed to it in the opposite direction. As a result, the additional final drive from the vertical position is transferred to a tilted position from the vertical, thereby reducing the agrotechnical clearance from 870 to 600 mm, and the tractor becomes a low clearance machine.

The additional final drive in all positions is fixed on the one hand by fixing the elements 11 of the rotation of the fixing flange 12 relative to the bracket 9 for hanging devices, by fixing sleeve 10 of the rear axle shaft 1, and on the other hand with the help of a hydraulic cylinder lock.

In the developed mechanism for changing the rear axle clearance, the most loaded parts are the rolling bearings of the cage on the rear axle casing, where needle bearings are used 4074832 [20], the design diagram of which is shown in Figure.3. In the paper provided parameters of the needle bearing received after calculation.

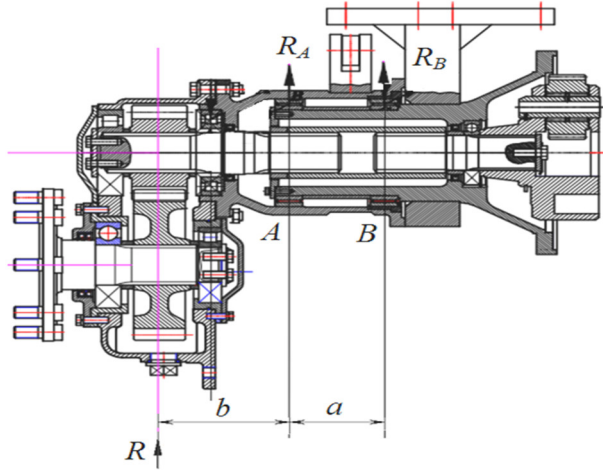

**Fig. 3.** Design diagram of the cage needle bearings

## 2 Materials and methods

This method applies to single-row radial needle roller bearings with or without an inner ring, with or without a cage in diameters 8, 9, and 1, and specifies their main dimensions and technical requirements.

This method does not apply to single-row radial needle roller bearings with a pressed outer ring.

## 3 Results and discussion

The parameters of the needle bearing taken as the initial data for the calculation are presented in Table 1, according to which the durability of the bearings was determined.

The calculated durability of needle bearings was determined by the following expression [20].

$$L_{hi} = \frac{5}{3} \cdot \frac{10^4}{n_i} L_i, \tag{1}$$

where  $L_i$  – bearing durability;  
 $n_i$  – bearing rotation speed.

Bearing durability was calculated as follows:

$$L = \frac{1}{k_h} \cdot \left( \frac{C}{P_{ri}} \right)^{10/3}, \tag{2}$$

where  $k_h$  – coefficient takes into account reliability indicators;  
 $C$  – dynamic bearing capacity;  
 $P_{ri}$  – reduced load acting on the bearing.

The dynamic load capacity of the needle bearing is as follows:

$$C = f_c (l_p)^{\frac{7}{9}} (z)^{\frac{3}{4}} (D_p)^{\frac{29}{27}}, \tag{3}$$

where  $f_c$  – coefficient depending on the geometry of the bearing parts;  
 $l_p$  – length of the roller in the bearing;

$z$  – the number of rolling bodies;  
 $D_p$ – diameter of the roller in the bearing.  
 Static load rating of needle bearing

$$C_0 = 21.6zD_p l_p, \tag{4}$$

Condition for the operability of the needle bearing

$$L_h \geq T_c, \tag{5}$$

where  $T_c$  – the working life of the tractor.

**Table 1.** Calculation results.

Parameter	Unit	Numerical value
Needle bearing		4074832
Maximum soil reaction to the rear wheel, R	N	18737,1
Bearing inner diameter, d	mm	160
Bearing outer diameter, mm	D	200
Nominal bearing width, mm	B	40
Diameter of the circle passing through the centers of the rollers, mm	D <sub>0</sub>	180
Roller diameter in bearing, mm	D <sub>p</sub>	3,5
Roller length in bearing, mm	l <sub>p</sub>	30
The number of rolling elements in one row of the bearing, pcs.	z	180
Dimensions, mm	a b	141 183
Factor taking into account reliability indicators	kh	1,30
Working resource of the tractor, h	T <sub>c</sub>	9000

According to the described method, we calculated the values of the quantities and used them to determine the operability of the needle bearing (table 2).

## 4 Conclusions

Based on the research carried out, the following conclusions can be drawn:

1. The parameters incorporated into the design of the details of the mechanism for changing the clearance of the rear axle of the tractor ensure its reliable operation.
2. The calculated service life of the bearings 4074832 significantly exceeds the working life of the tractor.
3. Bearing 4074832 is applicable as a rolling bearing of the cage on the rear axle casing in the developed mechanism for changing the rear axle clearance.

**Table 2.** Calculation results

Parameter	Designation	Numerical value
Radial bearing reaction in points A, N	R <sub>A</sub>	43055,46
Radial bearing reaction in points B, N	R <sub>B</sub>	24318,36
Static load in the bearing, N	C <sub>0</sub>	408240
Bearing part coefficient related to the design, N/mm	f <sub>c</sub>	60,80
Dynamic load in the bearing, N	D <sub>p</sub> /D <sub>0</sub>	0,019
Bearing's rotation ratio	C	161659
Coefficient of dynamic loads	V	1
Reduced load acting on the bearing, N	(a)	0.129
Maximum tangential speed in the rod of the hydraulic cylinder, m/s	P <sub>ca</sub>	43055,46

The radius of the circle along which the hydraulic cylinder rod moves, m	$P_{cB}$	24318,36
Maximum RPM, $\text{min}^{-1}$	<b>(b)</b>	0.148
Nominal life, million revolutions	<b>(c)</b>	0.167
Bearing resources, h	h	0,190
Bearing pressure, Pa	p	7,438
Bearing durability in point A	LA	63,284
Bearing durability in point B	LB	424,887
Condition for the operability in point A	$L_{hA}$	141796
Condition for the operability in point B	$L_{hB}$	952013
Comparison of condition for the operability in point A and working life of the tractor.	$L_{hA} \geq T_c$	Performed
Comparison of condition for the operability in point B and working life of the tractor.	$L_{hB} \geq T_c$	Performed

## References

- 1 V. A. Nikolaev, *Changes in the agrophysical properties of soil depending on the compacting effect of wheeled tractors*, J. Agriculture, **3**, 24-25 (2015)
- 2 V. L. Astafiev, *Tractor drive systems and soil compaction*, Agricultural sector, **1**, 27, (2016)
- 3 V. M. Zabrodsky et al, *Tractor running systems*, 272 (Agropromizdat, Moscow, 1986)
- 4 A. V. Rusinov, V. V. Slyusarenko, T. V. Fedyunina, *Determination of the area of compaction of agricultural fields by propellers of machine-tractor units*, International research journal, **1** (43), 35-37 (2016)
- 5 F. I. Uchevatkina, *Handbook of cotton growing*, 872 (Tashkent, Uzbekistan, 1965)
- 6 R. D. Matchanov, *Cotton pickers 1929-2010*, 354. (Tashkent, 2011)
- 7 V. A. Rusanov, *Impact of tractor propellers on the soil and its fertility Mechanization and electrification of agriculture*, **3**, 3-8 (Moscow, 1993)
- 8 V. V. Slyusarenko, A. V. Rusinov, T. V. Fedyunina, *The influence of the propellers of machine-tractor units on the yield of agricultural crops*, International scientific research journal, **3** (3rd part), 120-122 (2016)
- 9 V. V. Guskov, *Tractors*, 384 (Higher School, Minsk, 1977)
- 10 A. P. Parfenov, *Trends in the development of structures of agricultural tractors*, Tractors and agricultural machines, **5**, 42-47 (2015)
- 11 V. Ya. Anilovich, Yu. T. Vodolazhchenko, *Design and calculation of agricultural tractors*, 456 (Moscow: Mechanical Engineering, 2016)
- 12 T. Baiyirov, S. Mamadzhonov, M. Olmasov, A. Rajabov, B. Artykbaev, S. Voinov, A. Tolybaev, B. Gaibullaev, *Agricultural machinery. Cars (Catalog)*, 480 (IMESKh, Muxammadpoligraf, Tashkent, 2016)
- 13 A. Akhmetov, Sh. Akhmedov, R. Botirov, D. Kambarova, *Pressure on the Soil of the Front Wheels of Tractors with Different Wheel Formulas*, International Journal of Innovative Technology and Exploring Engineering (IJITEE), **9** (5), 316-319 (2020)
- 14 A. G. Bondarev, P. M. Sapozhnikov, V. F. Utkava, V. N. Schepotev, *Changes in the physical properties and fertility of soils when they are compacted by the movers of*

- agricultural machinery*, Coll. scientific. tr. VIM. 46-57. (Moscow, 1988)
- 15 I. I. Vodyanik, *The work of the wheel with multiple passes along the same track Mechanization and electrification of agriculture*, **2**, 34-36 (Moscow, 1982)
  - 16 D. I. Zolotarevskaya, *Calculation of soil compaction with wheeled tractors*, Tractors and agricultural machines, **6**, 10-13 (Moscow, 1990)
  - 17 A. A. Akhmetov, *Universal row-crop tractors for inter-row cultivation of cotton crops*, 240 (Science, Tashkent, 2017)
  - 18 A. A. Akhmetov, Sh. A. Akhmedov, *Cotton-growing universal row-crop tractor with adjustable ground clearance*, 200 (Science, Tashkent, 2016)
  - 19 A. A. Akhmetov, Sh. A. Akhmedov, D. A. Ruziev, R. M. Botirov, *Development of a mechanism for changing the clearance of the rear axle of a tractor with a rack and pinion drive Innovative approaches in solving problems of modern society*, Collection of articles of the II International Scientific and Practical Conference, 9-13 (ICNS "Science and Education", Penza, 2018)
  - 20 V. N. Naryshkina, *Rolling bearings: Directory-catalog*, 280 (Mechanical Engineering, Moscow 1984)
  - 21 M. O. Amonov, A. S. Pulatov, T. S. Colvin, *Machine innovation for inter row cotton cultivation in Uzbekistan*, Applied engineering in agriculture, **22**(5), 665-674 (2006)
  - 22 A. Akhmetov, R. Botirov, S. Abdurokhmonov, *Mechanism for changing the rear axle clearance of a universal-tiller tractor*, IOP Conference Series: Materials Science and Engineering 883(1) (2016)