

Proteus/Simulink Analysis of Rectifier based E-Vehicle Charger Circuit

Mr.R.Thangasankaran^{1}, Dr.S.Parthasarathy²*

¹Assistant Professor/EEE, Ramco Institute of Technology, Rajapalayam, Tamilnadu, India

²Professor/EEE, K.L.N. College of Engineering, Pottapalayam, Sivagangai, Tamilnadu, India

Abstract. In this paper, an AC to DC rectifier circuit has been discussed and the simulation results are provided. This converter is very useful for the upcoming development of the electric vehicles charging technology. For producing steady DC from a rectified AC supply requires a smoothing circuit or filter. The main purpose of the filter circuit is to remove the ripple or ac components from the output of the diode circuit. So, to make the output DC pure, the filter circuit is used. The filter circuit may be inductive (built with only inductors in series) or capacitive (built with only capacitors in parallel) or Inductive-Capacitive (built with both inductors and capacitors). A voltage regulator which is used to maintain the constant output DC voltage. Design of the controller is detailed for reference. The converter will operate in continuous conduction mode (CCM). Finally, some selected experimental results are presented to verify the proposed theory.

Keywords – AC to DC rectifier, Electric vehicle, CCM, Battery charging, Smoothing capacitor, Voltage regulator

1. Introduction

These days, there are many purposes behind the advancement of electric vehicles (EVs). The most important reasons are increasing of fuel cost, lacking in energy resources and reduce the greenhouse gas emission [4]. The advantages of using the EVs can be stated as, being a source of the clean energy, having high efficiency when compared to the conventional vehicles and producing less noise than the conventional vehicles [13]. But the supply for the EV is from the battery. This paper provides a solution for charging of EV batteries.

L. Sri Sivani, Nagi Reddy B, K. Subba Rao, A. Pandian has proposed a paper on A New Single Switch AC/DC Converter with Extended Voltage Conversion Ratio for SMPS Application, which is an AC/DC converter having a buck-boost PFC circuit that operates in discontinuous conduction mode (DCM) to attain unity input power factor and a buck converter to achieve tightly regulated voltage along with wide conversion range [1]. The proposed converter doesn't require extra control technique to achieve unity power factor.

M. Bhaskara Rao, T. Lokanadha Rao, Nagalla Sowjanya, T. Jaganmohan Rao proposed a paper which titled as An Efficient AC-DC Step up Converter for Low voltage Harvesting Applications. In this paper, presents an efficient ac-dc power converter that avoids the bridge rectification and directly converts the low ac input voltage to the required high dc output voltage at a higher efficiency [18]. The proposed converter consists of a

* Corresponding author: goldasankaran@gmail.com

boost converter in parallel with a buck–boost converter, which are operated in the positive half cycle and negative half cycle, respectively.

Ching-Tsai Pan, and Tsung-Cheng Chen has proposed a paper on Modelling and Design of an AC to DC Converter. this paper, a step-up-down single-phase ac-to-dc converter without current sensor is proposed to achieve high performance and simple control logic. The converter adopts a front-end diode rectifier so that only one active switch is required [2]. Unlike the existing model, which is valid only for very low frequency range, namely below line frequency, the proposed model is applicable up to half switching frequency.

2. Block Diagram

The block diagram of rectifier that was built with four important parts such as step-down transformer, a diode circuit, a filter circuit, and a voltage regulator circuit.

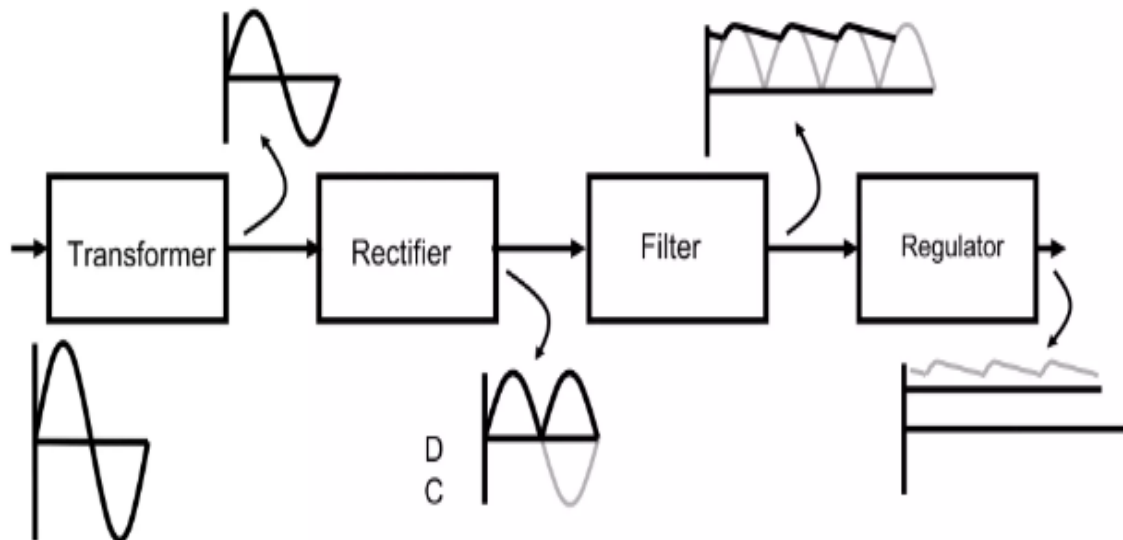

Fig. 1. Block Diagram

The transformer is a device that steps up or steps up the voltage. The normal step-down transformer is used when it is a bridge rectifier circuit. Now coming to the diode circuit, that is a very important part of the rectifier. The diode circuit is made of four diodes. The full-wave bridge rectifier circuit is built with four PN junction diodes. The bridge rectifier is the most efficient among all and is nowadays mostly used.

The main purpose of the filter circuit is to remove the ripple or ac components from the output of the diode circuit. The diode circuit converts alternating current (AC) into Direct Current (DC) but it is not in pure form. So, to make the output DC pure, the filter circuit is used. The filter circuit may be inductive (built with only inductors in series) or capacitive (built with only capacitors in parallel) or Inductive-Capacitive (built with both inductors and capacitors).

The main objective to use a voltage regulator circuit is to keep the output voltage level constant even when the input voltage or output load fluctuates or changes. Generally, a

Zener diode is connected in parallel with reverse for voltage regulation. Or the voltage regulator ICs.

3. Circuit Configurations

A rectifier is an electronic device or circuit that converts the Alternating Current (AC) into Direct Current (DC). The main component of a rectifier circuit is the PN Junction Diode. A rectifier circuit may use a four PN Junction Diodes (for bridge rectifier). Actually, the diode converts the AC into DC. The other parts of the rectifier are also important.

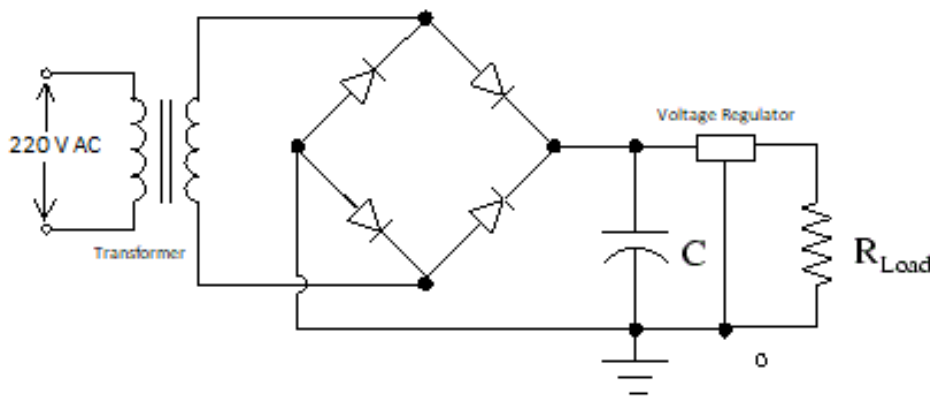

Fig. 2. Circuit Diagram

The proposed converter is designed for charging of E-Vehicle batteries. The output voltage of this converter will be remains constant and regulated by using the ICs. By using the smoothing capacitor at the end of the circuit. It will reduce the output ripple voltage.

4. Components Specifications

There are four main components used in this rectifier circuit. They are transformer, bridge rectifier, smoothing capacitor and voltage regulator. When an AC signal is applied across the bridge rectifier, we notice that the current flow across load resistor R_L is the same during the positive and negative half-cycles. The output DC signal polarity may be either completely positive or negative.

Table 1. Design Specification of the Rectifier

Parameters	Values
Input AC voltage	230 V AC
Step-down Transformer	230 V AC to 24 V AC
Bridge Rectifier	KBPC3510
Capacitor	4400 μ F
Voltage Regulator	LM4824
Output Voltage	24 V DC

In this case, it is completely positive. If the diodes' direction is reversed, the obtained DC voltage is completely negative. Thus, a bridge rectifier allows electric current during both positive and negative half cycles of the input AC signal.

5. Simulation and Waveforms

The simulation work of this AC to DC rectifier is done with the help of proteus simulation application. By using this all the data of the converter is taken and displayed below.

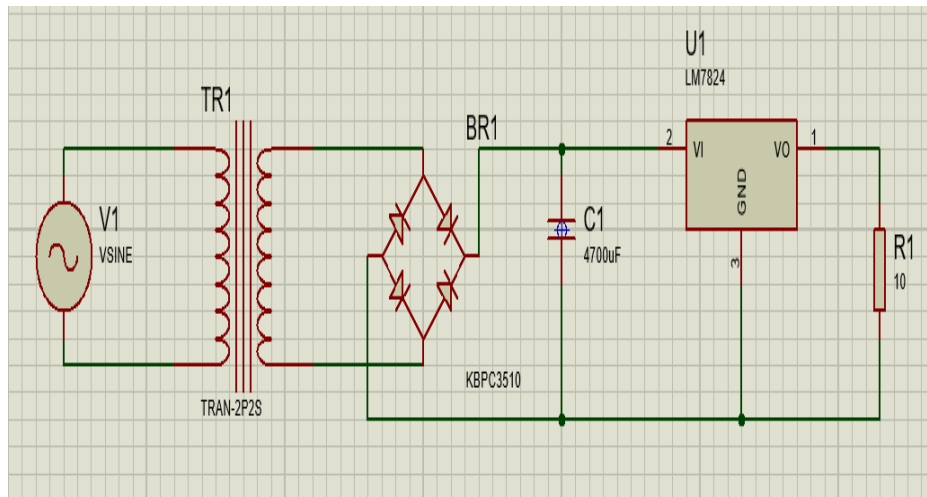

Fig. 3. Simulation circuit

The output waveforms of the AC to DC rectifier are shown in the below figure, Fig-4 shows the input waveform from the supply which has the amplitude of 230 V in the supply. This supply is given to the bridge rectifier circuit.

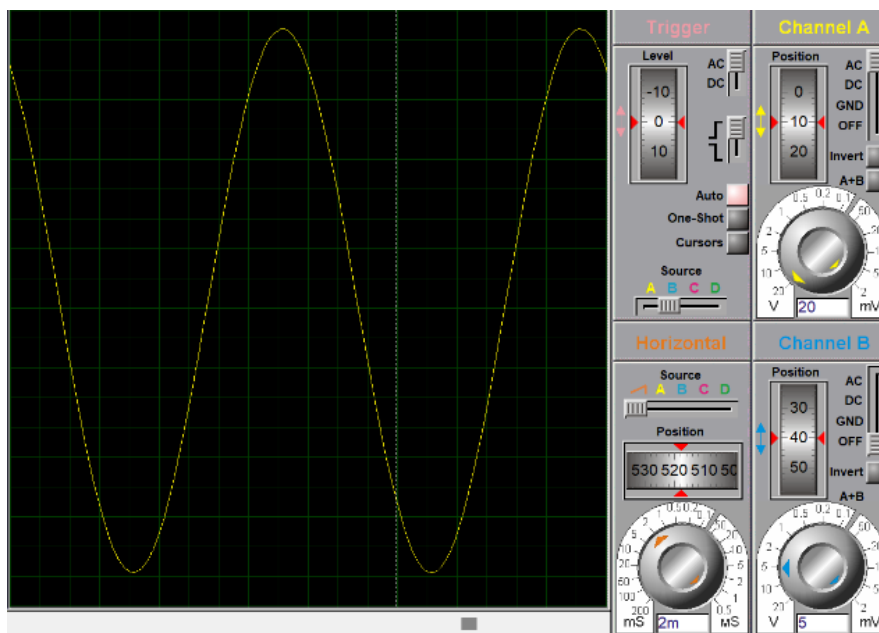

Fig. 4. AC Input waveform

Fig-5 shows the rectified waveform which is done by the bridge rectifier. But this is not the pure DC voltage waveform. So, this is not preferred to give to the battery.

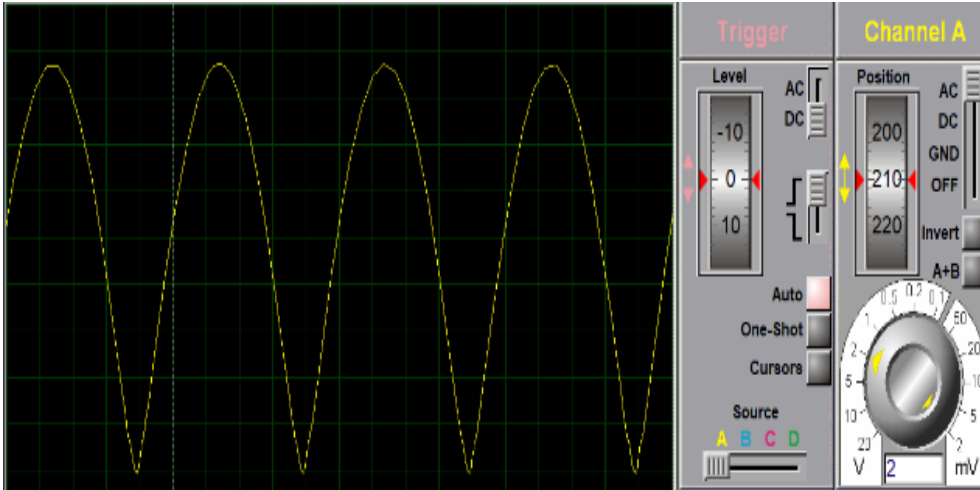

Fig. 5. Output waveform from bridge rectifier

Fig-6 shows the output smoothing capacitor voltage waveform this is partially a DC waveform. This is allow to charge the battery of the EVs.

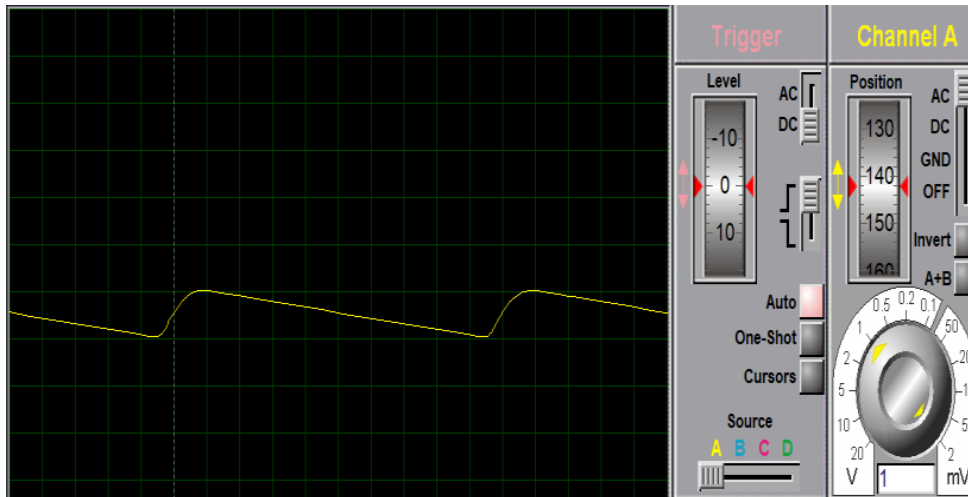

Fig. 6. Output waveform from smoothing capacitor

Fig-7 shows the pure DC output voltage, the voltage from the filter capacitor will be oscillated. Because, the capacitor will keep on charging. So, the voltage from the capacitor will not be constant and not preferred to give to the battery. So, a voltage regulator is used to kept the output DC voltage constant. This is the DC output voltage waveform of the rectifier circuit which is given to the battery.

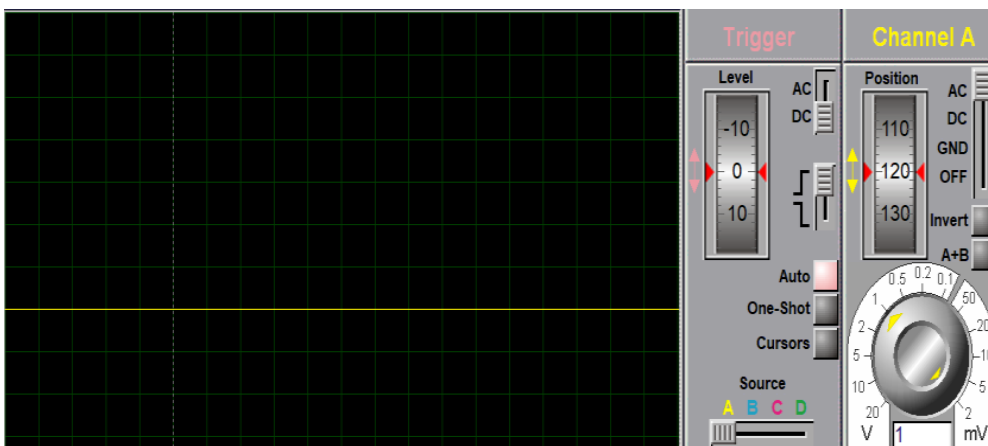

Fig. 7. Output waveform from the rectifier circuit

So, these are the simulation and its waveforms of the AC to DC converter circuit. All the necessary data are collected.

6. Results and Discussions

From the above simulations and waveforms results, all the readings are taken and tabulated.

Table. 2. Constant frequency and Variable AC voltage

V_{in}	Frequency	PF	V_o
250 V	50 Hz	0.98	24 V
230 V	50 Hz	0.96	24 V
210 V	50 Hz	0.955	24 V
190 V	50 Hz	0.951	24 V
170 V	50 Hz	0.94	24 V
150 V	50 Hz	0.92	24 V
130 V	50 Hz	0.89	24 V
110 V	50 Hz	0.85	24 V

Table-2 show the output voltage and power factor of the rectifier circuit under the input AC voltage is varied. The frequency of the system is kept constant and the input AC voltage only varying. With respect to the input voltage the power factor of the system is varying. When the input AC voltage is decreased, the power factor is also decreased.

Table. 3. Constant AC Voltage and Variable Frequency

V_{in}	Frequency	PF	V_o
230 V	50 Hz	0.96	24 V
230 V	47 Hz	0.954	24 V
230 V	44 Hz	0.949	24 V
230 V	40 Hz	0.943	24 V
230 V	38 Hz	0.937	23.8 V
230 V	35 Hz	0.931	23.3 V
230 V	32 Hz	0.923	23 V
230 V	30 Hz	0.889	22.5 V

Table-3 In this table, the input AC voltage is kept constant and the system frequency is varied. Hence with respect to the frequency, the power factor and output DC voltage is varying. When the frequency of the system is decreased, the power factor is decreased and somehow the output DC voltage is also slightly decreased.

7. Conclusion

In this paper, the design and analysis of the AC to DC diode bridge rectifier circuit for the charging of batteries in E-Vehicles are discussed. The simulation of the circuit diagram is done in proteus simulation application and the different waveforms of the circuit from different components are collected and they are placed above in this paper. Finally, the simulation work for different input AC voltage and frequency and the changes in output DC voltage and power factor based on the change in input are noted and tabulated. The

converter operates in the continuous conduction mode (CCM). The output DC voltage is ripple free and efficiency of the converter is high.

8. References

- [1] L. Sri Sivani, Nagi Reddy B, K. Subba Rao, A. Pandian” A New Single Switch AC/DC Converter with Extended Voltage Conversion Ratio for SMPS Applications” ISSN: 2278-3075, **Volume-8** Issue-3, January 2019, International Journal of Innovative Technology and Exploring Engineering (IJITEE).
- [2] Ching-Tsai Pan, and Tsung-Cheng Chen “Modelling and Design of an AC to DC Converter” IEEE TRANSACTIONS ON POWER ELECTRONICS. VOL X. YO 4. OCTOBEK 1993.
- [3] Prof. P. N. kapil, Tushar Vavaiya “Simulation of Closed Loop AC-DC Converter for Power Quality Improvement” ISSN: 2278-0181, **Vol. 4** Issue 03, March-2015, International Journal of Engineering Research & Technology (IJERT)
- [4] Sheng-Yang Yu, Xun Gong, Gangyao Wang and Manish Bhardwaj “Designing a High-Power Bidirectional AC/DC Power Supply Using SiC FETs” 2020 Texas Instruments Power Supply Design Seminar SEM2400.
- [5] M. Senthilkumar K.P. Suresh T. Guna Sekar C. Pazhani Muthu, “Efficient Battery Monitoring System for E-Vehicles” 2021 7th International Conference on Advanced Computing & Communication System (ICACCS).
- [6] Kotla Aswini, Jillidimudi Kamala, Bugatha Ram Vara Prasad, Lanka Sriram, Bhasuru Kowshik, Damaraju Venkata Sai Bharani “Design and Analysis of Bidirectional Battery Charger for Electric Vehicle” International Journal of Engineering Research & Technology (IJERT) **Vol. 10** Issue 07, July 2021.
- [7] Nikita N. Mutrak, Kaveri Pagar, Ankita Pawar, Ashwini Bodke, Dr. Mukesh K. Kumawat. “IoT-based Battery Monitoring System” International Research Journal of Engineering and Technology (IRJET) **Volume: 07** Issue: 06 June 2020.
- [8] M.M. Morcos, Curtis R. Mersman, G.D Sugavanam, Norman G. Dilman “Battery Chargers for Electric Vehicles” IEEE Power Engineering Review, November 2000.
- [9] Safy Saeeda, SK. A. Shezanb, M.I. Arbabc, Sohel Ranad. “Battery Monitoring System for the Smart grid applications” Australasian Universities Power Engineering Conference (AUPEC) 2017.
- [10] Dr.R. Essaki Raj, Poovizhi.S, Roshini Sathyamurthy, Rubadevi R “AC-DC Converter for Electric Vehicle Charger” International Research Journal of Engineering and Technology (IRJET) **Volume: 07** Issue: 06 June 2020.
- [11] Sayed Mahmud, Anika Bushra, Tamanna Sumaiya, Hossain Md Arafat, Rahman Md Ashiqur “Study of AC to DC Converter”.
- [12] C. Sathya, P. Kalaivani “IoT Based Battery Management System for Electric Vehicles” IJISSET - International Journal of Innovative Science, Engineering & Technology, **Volume 9**, Special Issue, May 2022.
- [13] Bharathi S.H, Y.V Nithin Reddy, Dinesh, Ram Gopal “IoT-Based Battery Monitoring System for Electric Vehicle” Turkish Journal of Computer and Mathematics Education **Vol.12** No.13 (2021).
- [14] Swapnil P. Karmore, Anjali R. Mahajan, Suruchi Kitey “Battery Monitoring and Analysis based system” 2013 IEEE.

- [15] N. Harish V Prashal and Dr. D.Sivakumar “IOT based Battery Management System” International Journal of Applied Engineering Research ISSN 2018.
- [16] Mohd Helmy Abd Wahab Nur Imanina Mohammed Anaur, radzi amb ar, Aslina Baharum, Shanoor Shanta, Mohd Suffian Sulaiman Shukor Sanim Mohd Fauzi, Hazibul Fahri Hanafi “IOT-Based battery Monitoring System for Electric Vehicle” International Journal of Engineering & technology 2018.
- [17] Chien-Wu Lan, Shih-Sung Lin, Sih-Yan Syue, Hao-Yen Hsu, Tien-Cheng Huang, Kuang-Hsiung Tan, “Development of an Intelligent Lithium-Ion Battery-Charging Management System for Electric Vehicle” 2017 IEEE International Conference on Applied System Innovation.
- [18] M.Bhaskara Rao, T. Lokanadha Rao, Nagalla Sowjanya, T.Jaganmohan Rao “An Efficient AC-DC Step up Converter for Low voltage Harvesting Applications” ISSN: 2455-2631, IJSDR | **Volume 1**, Issue 7, July 2016, International Journal of Scientific Development and Research (IJSDR).
- [19] Wang Menghua, Xiao Bing “A Real-time Android-based Monitoring System for the Power Lithium-ion Battery Used on Evs” 2017 10th International Conference on Intelligent Computation Technology and Automation.
- [20] Dimas Anton Asfani, Yulistya Negara, Gusti Ngurah Satriyadi Hernanda, Daniar Fahmi, Muhammad Nur Yuniarto, Rizal Hardiyanto, Raditya Premananda “Real-Time Battery Monitoring and Fault Identification Application on Electric Scooter” 2019 International Seminar on Application for Technology of Information and Communication.
- [21] Irsyad Nashirul Haq, Edi Leksono, Muhammad Iqbal, FX Nugroho Soelami, Nugraha, Deddy Kurniadi, Brian Yuliarto “Development of Battery Management System for Cell Monitoring and Protection” 2014 IEEE International Conference on Electrical Engineering and Computer Science.
- [22] Selamat Muslimin, Renny Maulidda, Evelina Evelina, M. Nawawi, Iskandar Lutfi, Johansyah Al Rasyid, M. Fadli, Puput Anggraini, M. Yusuf, Wanda Merian PA “Energy Management on Electric Vehicles Using Fast Charging Banking Capacitor using Internet of Things (IoT) System” 5 th T1 T2 2021 International Conference