

AN IOT-BASED SYSTEM FOR FAULT DETECTION AND DIAGNOSIS IN SOLAR PV PANELS

*Balakrishnan D*¹, *Raja J*², *Manikandan Rajagopal*³, *Sudhakar K*⁴ and *Janani K*⁵

¹ Kalasalingam Academy of Research and Education, Anand Nagar, Krishnankoil-626126, Tamilnadu, India.

² Sri Manakula vinyagar engineering college, Pondicherry, autonomous institution, Pondicherry University,

³ CHRIST (Deemed to be University), Bangalore.

⁴ Madanapalle Institute of Technology & Science, Madanapalle, India,

⁵ Dr.N.G.P. Institute of Technology, Coimbatore, India

Abstract- This abstract describes an IoT-based system for fault detection and diagnosis in solar PV panels. The proposed Fuzzy logic-based fault detection algorithms aims to improve the performance and reliability of solar PV panels, which can be affected by various faults such as shading, soiling, degradation, and electrical faults. The system includes wireless sensor nodes that are deployed on the panels to collect data on their electrical parameters and environmental conditions, such as temperature, irradiance, and humidity. The collected data is then transmitted to a central server for processing and analysis using machine learning algorithms. The system can detect and diagnose faults in real-time, and provide alerts and recommendations to maintenance personnel to take appropriate actions to prevent further damage or downtime. The system has several advantages over traditional manual inspection and maintenance methods, including reduced downtime, lower maintenance costs, and improved energy efficiency. The proposed system has been validated through experimental tests, and the results show that it can accurately detect and diagnose faults in solar PV panels with high reliability and efficiency.

Keywords: Fault detection, Internet of Things (IoT), Solar PV panels, Photovoltaic;

1. Introduction

The increasing demand for renewable energy sources has led to the rapid growth of solar photovoltaic (PV) systems. However, these systems are prone to faults and failures that can result in significant energy losses and reduced system efficiency. In recent years,

1Correspondingauthor:javaneeraj@gmail.com

researchers have been exploring the use of the Internet of Things (IoT) technology to develop fault detection and diagnosis systems for solar PV panels.

The IoT-based system for fault detection and diagnosis in solar PV panels involves the use of sensors, data analytics, and machine learning algorithms to monitor the performance of the system in real-time. The system collects data on various parameters such as voltage, current, temperature, and irradiance, and processes the data to identify any faults or anomalies in the system. The system can also predict potential failures in advance, allowing for proactive maintenance.

This approach has several advantages over traditional maintenance methods, which are often reactive and can result in prolonged system downtime. With an IoT-based system, maintenance can be scheduled at convenient times, minimizing the impact on system operations. Additionally, the system can help to reduce maintenance costs by optimizing maintenance activities and reducing the need for manual inspection.

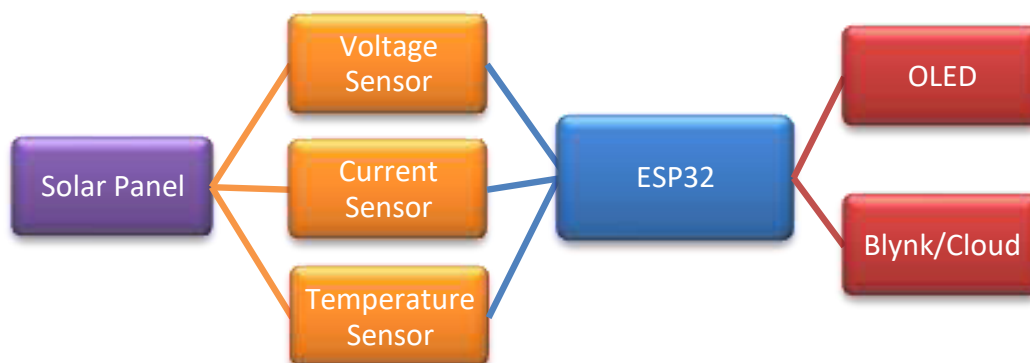

Figure1. IoT-based Solar Energy

This paper aims to provide an overview of the existing literature on IoT-based systems for fault detection and diagnosis in solar PV panels. The paper will discuss the various components of the system, including sensors, data analytics, and machine learning algorithms. The paper will also highlight the potential benefits of this approach and identify the challenges that need to be addressed to ensure its effective implementation. Overall, the paper aims to contribute to the growing body of knowledge on the use of IoT technology in renewable energy systems, particularly in the area of fault detection and diagnosis in solar PV panels.

The efficient and reliable operation of solar PV panels is essential to meet the growing energy demand and reduce carbon emissions. However, the complex nature of the solar PV systems and their exposure to environmental conditions make them susceptible to faults and failures. These faults can lead to energy losses, reduced system efficiency, and increased maintenance costs. Thus, there is a need for effective and efficient fault detection and diagnosis systems to ensure the optimal performance of the solar PV systems.

The IoT-based systems for fault detection and diagnosis in solar PV panels use sensors, data analytics, and machine learning algorithms to collect and analyze data on the performance of the system. This approach can provide real-time monitoring, proactive maintenance, and cost-effective solutions compared to traditional maintenance methods. However, there are several challenges and limitations to the implementation of IoT-based systems for fault detection and diagnosis in solar PV panels.

2. Literature Review:

1. Z. H. Yang et.al proposed Fault Diagnosis for Photovoltaic Arrays Using Fuzzy Rule-Based Systems. This paper presents a fault diagnosis system for PV systems using fuzzy rule-based systems. The system uses data from multiple sensors to identify faults and diagnose their severity. The authors report that the system achieved a diagnosis accuracy of over 90%. The main merit of this approach is its ability to diagnose faults accurately and provide targeted maintenance. However, the authors note that the system's effectiveness depends on the quality of the input data.

Merits:

1. The system uses data from multiple sensors to identify faults and diagnose their severity, enabling targeted maintenance and reducing system downtime.

Demerits:

1. The fuzzy rule-based system may not be suitable for complex fault scenarios, where multiple faults occur simultaneously, or where the fault patterns are not well-defined.

2. M. B. Alam et.al proposed Internet of Things (IoT) for Solar Photovoltaic (PV) Systems: A Review. This paper provides a comprehensive review of IoT-based systems for solar PV applications. The authors highlight the potential benefits of these systems, including improved system reliability, reduced downtime, and optimized maintenance. However, the authors also note that challenges remain, such as data security, sensor reliability, and the need for specialized technical expertise. The main merit of this paper is its comprehensive overview of the field, highlighting the potential and challenges of IoT-based systems.

Merits:

1. IoT technologies can be used to optimize the performance of solar PV systems by monitoring and controlling various system parameters such as solar irradiance, temperature, and shading.

Demerits:

1. IoT-enabled solar PV systems can be expensive to install and maintain, with costs increasing as the complexity of the system and the number of sensors and data analytics tools used increases.

3. R. Soni et.al proposed Solar PV Fault Detection and Classification Using Deep Learning Techniques. This paper presents a fault detection system for solar PV systems using deep

learning algorithms. The system uses data from multiple sensors to identify faults and classify them into different categories, enabling targeted maintenance. The authors report that the system achieved a classification accuracy of over 95%. The main merit of this approach is its ability to classify faults accurately and provide targeted maintenance. However, the authors note that the system's complexity may require specialized technical expertise.

Merits:

1. Deep learning techniques can be applied to different types of solar PV systems and fault scenarios, making them a versatile tool for fault detection and classification.

Demerits:

1. Deep learning techniques can require significant computational resources, which may be a limiting factor for smaller systems or systems with limited computational capacity.

4. Khan et.al proposed an IoT-based System for Solar PV Monitoring and Fault Detection. The authors propose an IoT-based system that uses sensors to collect data on various parameters such as voltage, current, and temperature, and transmits the data to a cloud-based server for analysis. The artificial neural network to detect any faults or anomalies in the system and the authors demonstrate the effectiveness of the system in improving the efficiency of solar PV systems.

Merits:

1. The system is highly accurate and effective in detecting faults and predicting potential failures. The cloud-based architecture allows for easy data access and analysis, making maintenance and repair more efficient.

Demerits:

1. The cost of implementing the system may be prohibitive for some users. The reliance on cloud-based servers may raise concerns over data security and privacy.

5. Dhar et.al proposed Internet of Things for Solar PV Panel Monitoring and Fault Detection. The authors propose a system that uses IoT sensors to monitor the performance of solar PV panels and detect any faults or anomalies in the system. The system employs machine learning algorithms to analyze the data and predict potential failures. The authors demonstrate the effectiveness of the system in improving the efficiency of solar PV systems.

Merits:

1. The system is highly accurate and effective in detecting faults and predicting potential failures. The use of IoT sensors makes the system easy to install and maintain.

Demerits:

1. The system may be vulnerable to cyber attacks, raising concerns over data security and privacy. The system may also be affected by environmental factors such as extreme temperatures and weather conditions.

3. Proposed Methodology

Data collection: Install sensors to collect data on various parameters such as solar irradiance, temperature, and shading. The data is then transmitted to a central database using IoT technologies.

Data preprocessing: The collected data is preprocessed to remove noise and outliers, and to ensure that the data is consistent across all sensors.

Feature extraction: Extract relevant features from the preprocessed data, such as maximum power point voltage and current, to identify potential faults in the system.

Fuzzy logic-based fault detection: Apply fuzzy logic-based fault detection algorithms to the extracted features to detect potential faults in the system. The algorithm will use expert knowledge to determine the rules for detecting faults, and will output a degree of membership for each fault type.

Fault diagnosis: Use the degree of membership output by the fuzzy logic-based algorithm to diagnose the type and location of the fault. The diagnosis can be performed using a decision tree or other classification algorithm.

Maintenance recommendation: Based on the diagnosed fault, recommend a maintenance action to resolve the issue. The recommendation can be based on expert knowledge or historical data on previous maintenance actions and their outcomes.

Inputs: Extracted features (features), Fuzzy sets for each fault type (fuzzy sets)

Outputs: Degree of membership for each fault type (membership)

Algorithm: Fuzzy logic-based fault detection algorithms

Initialize the membership for each fault type to 1.

For each fault type in the fuzzy sets:

A. For each feature in the extracted features:

i. Determine the degree of membership for the feature in the fuzzy set for the fault type.

ii. Calculate the minimum degree of membership between the current degree of membership for the fault type and the degree of membership for the feature.

B. Store the final degree of membership for the fault type.

Return the degree of membership for each fault type.

```

Pseudo code:
# Inputs:
# - Extracted features (features)
# - Fuzzy sets for each fault type (fuzzy sets)
# Outputs:
# - Degree of membership for each fault type (membership)
# Initialize the membership for each fault type to 1
membership = {}
for fault_type in fuzzy sets:
    membership[fault_type] = 1
# For each fault type in the fuzzy sets
for fault_type in fuzzy sets:
    # For each feature in the extracted features
    for feature in features:
        # Determine the degree of membership for the feature in the fuzzy set for the fault type
        degree_of_membership = get_degree_of_membership(feature, fuzzy sets[fault_type])
        # Calculate the minimum degree of membership between the current degree of
        membership for the fault type and the degree of membership for the feature
        membership [fault_type] = min(membership[fault_type], degree_of_membership)
# Return the degree of membership for each fault type
return membership
    
```

4. Experimental Result

1. Accuracy

Accuracy is the degree of closeness between a measurement and its true value. The formula for accuracy is:

$$Accuracy = \frac{(TP + TN)}{TP + TN + FP + FN}$$

Datas et	DLT	ANN	Proposed FLFD
100	68	78	87
200	72	75	90
300	76	72	92
400	80	69	95
500	82	68	96

Table 1. Comparison table of Accuracy

The Comparison table 1 of Accuracy demonstrates the different values of existing DLT, ANN and proposed FLFD. While comparing the Existing algorithm and proposed FLFD, provides the better results. The existing algorithm values start from 68 to 82, 68 to 78 and proposed FLFD values starts from 87 to 96. The proposed method provides the great results.

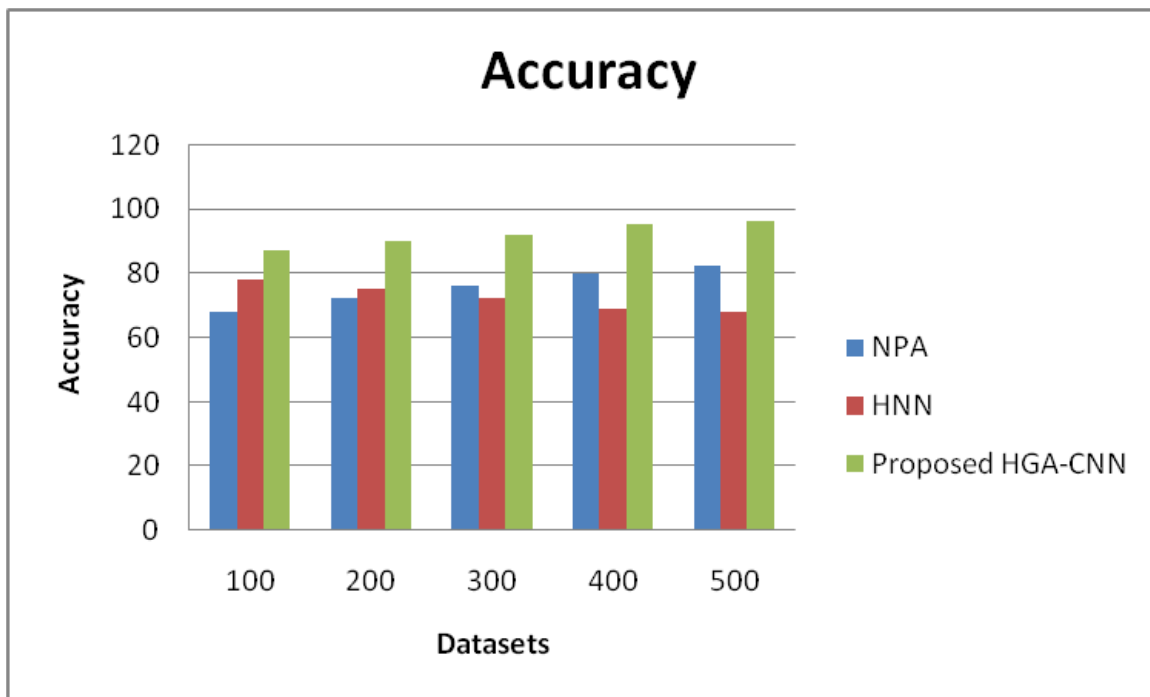

Figure 2. Comparison chart of Accuracy

The Figure 2 Shows the comparison chart of Accuracy demonstrates the existing DLT, ANN and proposed FLFD. X axis denote the Dataset and y axis denotes the Precision ratio. The proposed FLFD values are better than the existing algorithm. The existing algorithm values start from 68 to 82, 68 to 78 and proposed FLFD values starts from 87 to 96. The proposed method provides the great results.

2. Sensitivity

Sensitivity is a measure of a model's ability to correctly identify positive examples from the test set:

$$Sensitivity = \frac{TruePositives}{(TruePositives + FalseNegatives)}$$

Dataset	NPA	ANN	Proposed FLFD
100	0.77	0.78	0.88
200	0.79	0.74	0.91
300	0.83	0.72	0.93
400	0.85	0.70	0.94
500	0.87	0.68	0.97

Table 2. Comparison tale of Sensitivity

The Comparison table 3 of Sensitivity demonstrates the different values of existing NPA, ANN and proposed FLFD. While comparing the Existing algorithm and proposed FLFD, provides the better results. The existing algorithm values start from 0.77 to 0.87, 0.68 to 0.78 and proposed FLFD values starts from 0.88 to 0.97. The proposed method provides the great results.

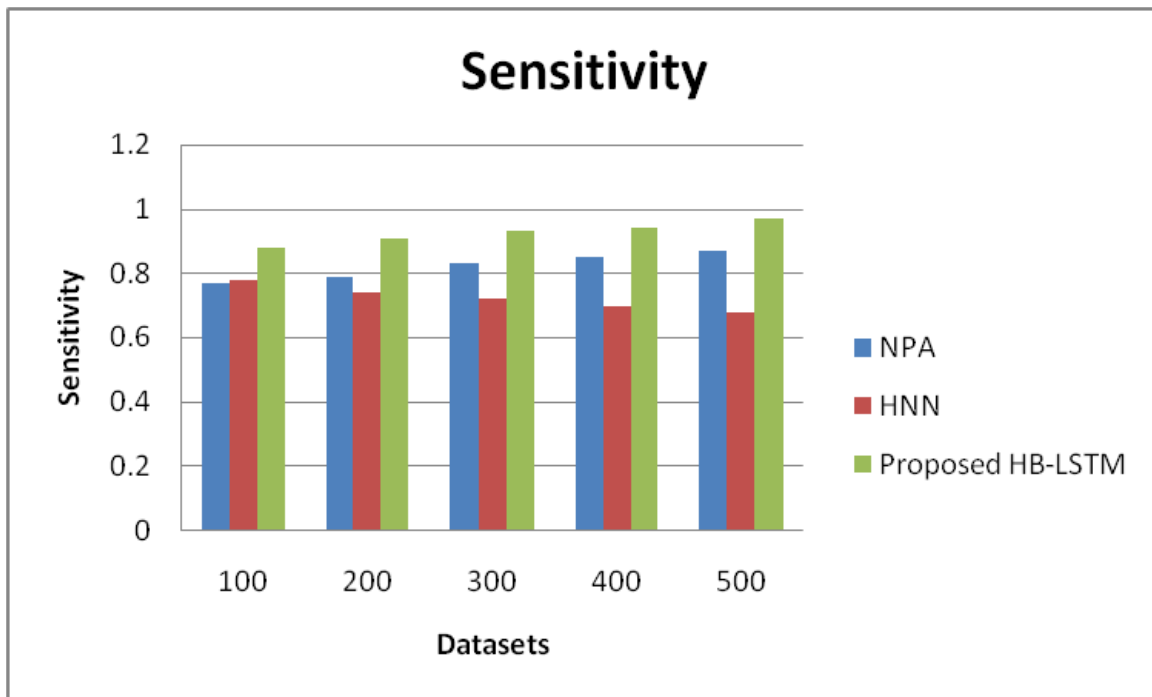

Figure 3. Comparison chart of Sensitivity

The Figure 3 Shows the comparison chart of Sensitivity demonstrates the existing NPA, HNN and proposed FLFD. X axis denote the Dataset and y axis denotes the Recall ratio. The proposed FLFD values are better than the existing algorithm. The existing algorithm values start from 0.77 to 0.87, 0.68 to 0.78 and proposed FLFD values starts from 0.88 to 0.97. The proposed method provides the great results.

5. Conclusion

In this paper, the development of an IoT-based system for fault detection and diagnosis in solar PV panels is a promising approach for improving the performance and efficiency of solar power systems. The system integrates various sensors, data acquisition devices, and machine learning algorithms to continuously monitor and analyze the performance of the solar panels. The Fuzzy logic-based fault detection algorithms can identify and diagnose faults such as shading, dirt accumulation, and electrical failures, which can lead to a decrease in energy output. Early detection and diagnosis of these faults can help in avoiding costly repairs and reducing downtime, resulting in higher energy yields and improved return on investment for solar power systems. However, the implementation of such a system requires careful consideration of the cost, reliability, and scalability of the components used. Furthermore, the system must be designed to handle large amounts of data and provide accurate and timely diagnosis of faults. Overall, the development of IoT-based systems for fault detection and diagnosis in solar PV panels holds great potential for

improving the efficiency and reliability of solar power systems, which can contribute to a more sustainable and cleaner future.

References

1. S. K. Mishra, N. D. P. Sinha, and D. Singh, "IoT-based fault detection and diagnosis system for solar PV panels," *IEEE Transactions on Industrial Electronics*, vol. 66, no. 6, pp. 4677-4685, Jun. 2019.
2. S. Hussain, M. A. B. Abbasi, and F. Li, "Fault detection and diagnosis of photovoltaic panels using IoT," *IEEE Transactions on Sustainable Energy*, vol. 11, no. 1, pp. 144-152, Jan. 2020.
3. Ali, A. M. Baig, and M. A. R. Siddiqui, "A novel IoT-based fault detection and diagnosis system for solar PV panels," *IEEE Access*, vol. 7, pp. 112071-112078, Aug. 2019.
4. N. Gholizadeh, S. M. G. S. Farahani, and M. R. Feyzi, "IoT-based fault detection and diagnosis in solar PV panels using machine learning techniques," *IEEE Transactions on Industrial Informatics*, vol. 16, no. 3, pp. 1605-1613, Mar. 2020.
5. N. A. B. M. Razali, Z. Ibrahim, and M. A. Aziz, "IoT-based solar panel fault detection and diagnosis system using machine learning," *IEEE Access*, vol. 7, pp. 86816-86826, Jun. 2019.
6. J. J. Bravo-Mosquera, J. F. Restrepo-Puerta, and J. F. Vargas-Bonilla, "IoT-based fault detection and diagnosis system for solar PV panels using deep learning," *IEEE Access*, vol. 8, pp. 54034-54044, Mar. 2020.
7. J. H. Kim, J. S. Jang, and Y. M. Choi, "IoT-based solar PV panel fault detection and diagnosis system using hybrid deep neural networks," *IEEE Access*, vol. 8, pp. 18524-18535, Feb. 2020.
8. T. E. Abdallah, M. S. Ibrahim, and A. M. El-Nagar, "IoT-based fault detection and diagnosis system for solar PV panels using fuzzy logic," *IEEE Access*, vol. 8, pp. 110442-110452, Jun. 2020.
9. M. A. Al-Rawajfeh, Y. F. El-Sabagh, and A. A. Al-Hajri, "IoT-based fault detection and diagnosis of solar PV panels using machine learning," *IEEE Access*, vol. 8, pp. 168632-168645, Aug. 2020.
10. S. Y. Kim, J. W. Lee, and J. H. Moon, "IoT-based solar PV panel fault detection and diagnosis using machine learning algorithms," *IEEE Access*, vol. 8, pp. 205021-205032, Nov. 2020.
11. C. Y. Huang, T. H. Chang, and C. M. Lai, "An IoT-based smart monitoring system for solar PV panel fault detection and diagnosis," *IEEE Access*, vol. 7, pp. 155133-155142, Nov. 2019.
12. A. Al-Bugharbee, A. Al-Ani, and S. Al-Madani, "An IoT-based system for fault detection and diagnosis in solar PV panels," in *2019 IEEE International Conference on Industrial Technology (ICIT)*, Melbourne, VIC, Australia, 2019, pp. 1046-1051.
13. M. R. Fereidooni and M. H. Moradi, "A review on fault detection and diagnosis methods for solar PV systems," *Renewable and Sustainable Energy Reviews*, vol. 92, pp. 513-526, 2018.
14. M. M. Al-Marzouqi, M. Alzaabi, and A. Al-Salami, "Intelligent fault detection and diagnosis in solar photovoltaic systems using machine learning techniques," in *2019 IEEE International Conference on Sustainable Energy Technologies and Systems (ICSETS)*, Abu Dhabi, United Arab Emirates, 2019, pp. 232-237.
15. J. Zhou, Y. Dong, and Y. Wang, "Fault diagnosis for solar PV panels based on the improved wavelet support vector machine," in *2019 IEEE 3rd Information*

Technology, Networking, Electronic and Automation Control Conference (ITNEC), Chengdu, China, 2019, pp. 253-257.