

Improvement of housing with knives crushers for non-tillage technology

Hamroqul Ravshanov^{1*}, *Farmon M. Maiviatov*^{1,2}, and *Sherzod Kurbanov*²

¹Karshi Institute of Irrigation and Agro technologies of the National Research University Tashkent
Institute of Irrigation and Agricultural Mechanization Engineers, Karshi, 180119, Uzbekistan

²Karshi Engineering Economic Institute, Karshi, 180100, Uzbekistan

Abstract. The paper gives justification of the options of the housing with crumbling knives for non-tillage technology. The dumpless housing with crumbles carries out intensive crumbling of the soil of the lower and middle arable soil layer. The body consists of a ploughshare, a ploughshare expander, knives and a chisel. When determining the parameters of a non-shaft housing based on a ploughshare, adopt a triangular wedge. Analytical dependences for determining the parameters of the components body without shaft are obtained. According conducted theoretical studies, without a tipper is 0.45 m, entry angle the ploughshare on the soil is 25°, nook of installation relative to the direction of travel is 42°, corner of installation with respect to the bottom egate is 35°, grinder the blade quantity 4, the elevated is 35 mm, the longitude is 120-140 mm, the angle of installation regarding the direction of peregrinate is 10°, the installation related to the skyline is 30°, the height body sans a tipper is 420 mm processing is provided.

1 Introduction

The technological process of basic tillage is traditionally carried out by ploughshares, but in recent years for these purposes, non-dump tillage tools and various combined tillage units have become widely used. It has long been known that in the production of agricultural products, basic tillage is the most energy-intensive operation, while its quality often does not meet the requirements of agricultural technology, which leads to a significant decrease in crop yields [1]. It is obvious that reducing energy intensity and improving the quality of basic tillage is an important economic problem. In general, tillage implies the impact of the surface of the working organ of the tillage tool on the arable layer in order to loosen it, that is, any method of tillage is essentially a method of crumbling or crushing the arable layer into fractions, the dimensions of which must meet agrotechnical requirements. Currently, the possibilities of improving the quality and reducing the energy intensity of the known methods of tillage, which are carried out by mass-produced tillage tools, have been practically exhausted [2]. The study of the processes of non-tillage tillage and the development of non-tillage working body implemented F Maiviatov [1, 2], O Hamroyev [4, 7], N Aldoshin [8, 22], F Mamatov [3, 7-18, 20, 21, 24] and others. In these studies, the matter developing and

* Corresponding author: ravshanovhamroqul@mail.ru

reasoning options body without tipping chopper blade, which works on the soil without tipping, have not been studied. The purpose study is to survey option hull with crumbling knives for non-tillage tillage.

2 Methods

When determining the parameters of a non-shaft housing based on a ploughshare, adopt a triangular wedge. The body without a tipper with a shredder blade is designed for intensive loosening of the soil. The body without a tipper with a chopper blade (Figure 1) consists of a column 1, a guide 2, a coulter expander 3, a coulter blade 4, a coulter 5 and an awl 6. The grinding blades installed in the body intensively soften and grind the middle part of the processed layer.

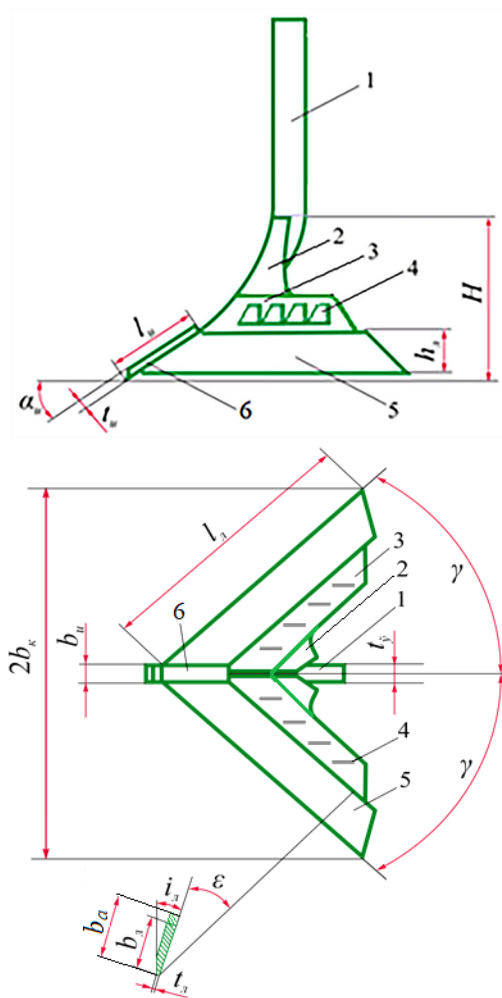

Fig. 1. The main parameters of the body without a tipper with a grinder blade: 1– rack; 2 – guide; 3 – ploughshare expander; 4 – knives; 5 – ploughshare; 6– chisels.

The parameters of the case without a tipper with a grinder blade were determined based on the case of the frontal plug. The body of the frontal plug became the basis for the body

without overturning. Therefore, the coverage width of the casing without a tipper is $b_k = 0.45$ m, the thickness, width and length of the shaft are respectively $t_i = 0.02$ m; $b_i = 0.035$ m and $l_i = 0.2$ m.

We determine its main parameters by accepting the ploughshare of the body without a tipper with a grinder blade in the form of a three-sided blade. It is known that under the action of pona, the soil breaks at a certain angle ψ with respect to the horizon, and displacement of the slabs along the fracture plane occurs (Figure 2). The following forces act on the three-sided plane in the plane ODS perpendicular to the plane blade AV : the weight of the plane G ; its dynamic pressure Pd due to the inertia of the blade; the friction force of the plate on the surface of the plate F ; the reaction of the undeformed soil in front is R . According to Figure 3, depending on the value of the rake, the plow can have two operating modes: the soil moves along the working surface of the plow or moves along with it, in which case it moves the soil in front of the plow. breaks down In order for the soil to move along the surface of the bed, the following condition must be met

$$\sum P_x = 0, \tag{1}$$

where P_x – is the sum of the projections of the forces acting on the plane on the X axis.

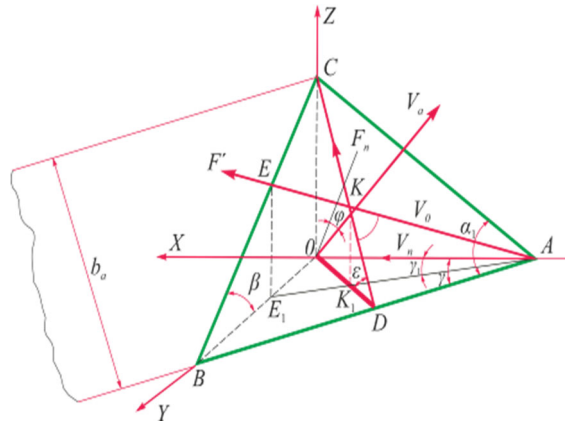

Fig. 2. Parameters of the three-side pony.

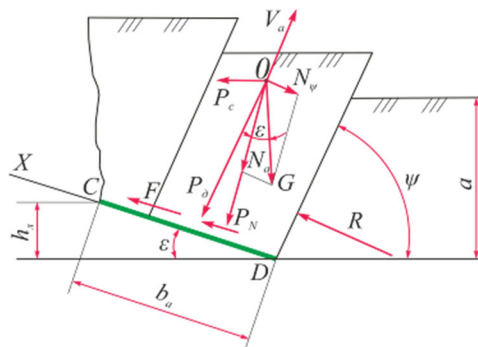

Fig. 3. The scheme of interaction of the plow with the turner- ploughshare.

To find the sum of the projections of all the forces on the X axis, we divide the gravity force G into the forces N_a and N_ψ perpendicular to the working surface of the blade and the plane of sliding of the blade (Figure 3). We determine these forces according to the following formula [2].

$$N_a = \frac{G \sin \psi}{\sin(\varepsilon + \psi)}, \quad (2)$$

$$N_\psi = \frac{G \sin \varepsilon}{\sin(\varepsilon + \psi)}, \quad (3)$$

where ε – corner of facility crops, that is, working surface plow relative to the bottom of the plow, in degrees; ψ – corner breaking of enrichment in flatness perpendicular to blade, degrees.

We determine the dynamic compressive strength of the soil P_d according to the following expression [3].

$$P_d = a l V_n \rho V_a, \quad (4)$$

where a – is processing depth, m; l – length of edge, m; V_n – the speed advancement of the vehicle, m/s; v_a – the absolute speed of the blade, m/s; ρ – soil density, kg/m³.

We define absolute speed edge according to the next expression [2].

$$V_a = \frac{V_n \sin \varepsilon}{\sin(\varepsilon + \psi)}, \quad (5)$$

In that case

$$P_d = \frac{a l V_n^2 \rho \sin \varepsilon}{\sin(\varepsilon + \psi)}. \quad (6)$$

The constituents of dynamic compressive strength of soil P_d

$$P_c = a l V_n^2 \rho \sin \varepsilon \operatorname{ctg}(\varepsilon + \psi) \quad \text{ba} \quad P_N = a l V_n^2 \rho \sin \varepsilon. \quad (7)$$

We determine the friction force F on the surface of the sheet (by DC) according to the following expression

$$F = (N_a + P_N) \operatorname{tg} \varphi \cos \delta, \quad (8)$$

where δ – is the direction of movement of the blade with the normal line CD , that is, the angle, degree, between the line AE ;

The value of δ is determined by the following expression [2]

$$\operatorname{tg} \delta = \operatorname{tg} \gamma \cos \varepsilon. \quad (9)$$

According to the expression (8), we add the values of N_a and P_N to (9).

$$F = \left[\frac{G \sin \psi}{\sin(\varepsilon + \psi)} + a l V_n^2 \rho \sin \varepsilon \right] \operatorname{tg} \varphi \cos \delta. \quad (10)$$

Maximum reaction force of undeformed soil

$$R_{\max} = S \sigma_s, \quad (11)$$

where σ_s – is the crushing resistance of the soil, Pa; S – is sliding surface, m².

Projecting the forces G , P_d , F ba R_{\max} onto the X axis, condition (3) can be expressed in the following form

$$a l V_n^2 \rho \sin \varepsilon \operatorname{ctg}(\varepsilon + \psi) + S \sigma_s \sin(\varepsilon + \psi) - G \sin \varepsilon - \left[\frac{G \sin \psi}{\sin(\varepsilon + \psi)} + a l V_n^2 \rho \sin \varepsilon \right] \operatorname{tg} \varphi \cos \delta \geq 0. \quad (12)$$

We determine the three-sided plow, i.e. b_a , the width ba of the body ploughshare, the sliding surface S and the weight of the blade G by the working depth a and the coverage width b_k of the body

$$l = \frac{b_k}{\sin \gamma}, \quad (13)$$

$$S = \frac{al}{\sin \psi} = \frac{ab_k}{\sin \psi \sin \gamma}, \quad (14)$$

$$G = alb_a \rho g = \frac{ab_a b_k \rho g}{\sin \gamma}, \quad (15)$$

where b_a – is the width of the blade expander part of the body without the grinder blade lifter, m.

According to expressions (13)-(15), putting the values of l , S and G in (12), we get the following

$$\begin{aligned} & \frac{ab_k V_n^2 \rho \sin \varepsilon \operatorname{ctg}(\varepsilon + \psi)}{\sin \gamma} + \frac{\sigma_g ab_k \sin(\varepsilon + \psi)}{\sin^2 \psi \sin \gamma} - \frac{ab_a b_k \rho g}{\sin \gamma} \sin \varepsilon - \\ & - \left(\frac{ab_a b_k \rho g \sin \psi}{\sin(\varepsilon + \psi) \sin \gamma} + \frac{ab_k V_n^2 \rho \sin \varepsilon}{\sin \gamma} \right) \operatorname{tg} \varphi \cos \delta \geq 0. \end{aligned} \quad (16)$$

From the expression (16), we get the following expression to determine the width of the blade expander part of the body without the chopper blade tipper.

$$b_a \leq \frac{\rho V_n^2 \sin \varepsilon \sin \psi [\cos(\varepsilon + \psi) - \sin(\varepsilon + \psi) \operatorname{tg} \varphi \cos \delta] + \sigma_g \sin^2(\varepsilon + \psi)}{\rho g [\sin \varepsilon + \sin(\varepsilon + \psi) \operatorname{tg} \varphi \cos \delta] \sin \psi}. \quad (17)$$

Calculations made according to the expression (17) revealed the width of edges expander part of fraction without grinder blade lifter should be in the range of $b_a = 170-176$ mm at speeds of 1.7-2.5 m/s. It was determined by the expression of the angle of entry of the plow and plow of the body without a tipper with a shredder blade into the soil [4].

$$\alpha = \operatorname{arctg}(\operatorname{tg} \varepsilon \sin \gamma). \quad (18)$$

According to the expression (19), the angle of entry of the plow blade and plow into the soil without a tipper with a shredder blade was equal to $\alpha = 25^\circ$.

3 Results and discussions

In the case without a chopper knife lifter, a knife type chopper is installed after the ploughshare (Figure 4). When parameter definition grinder edge, cross-section cut under its influence was assumed to be a circle. Knives are installed in the body guide without a tipper at such an angle that their setting comparative to the line move should correspond to direction of movement of soil particles along the ploughshare (Figure 4). Then the blades will have the smallest drag resistance. Based on this, $\theta_n = 8 - 10^\circ$.

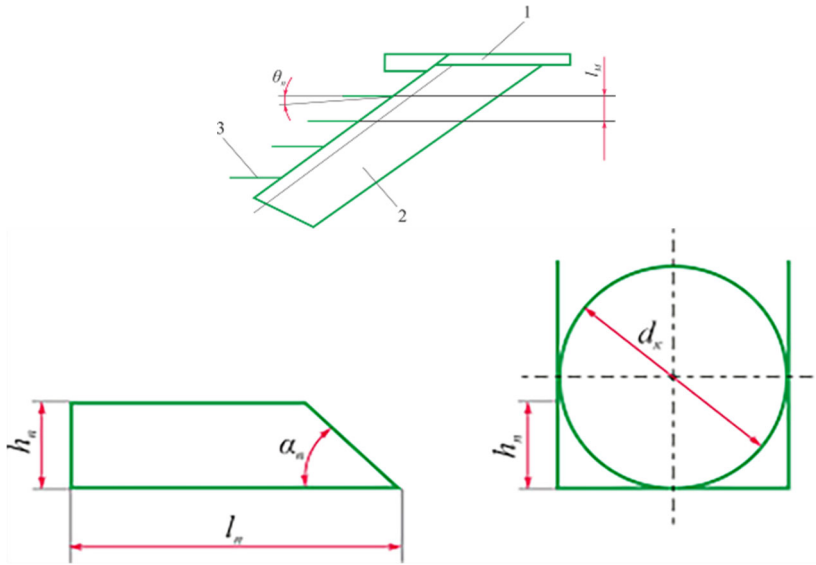

Fig. 4. Parameters of the crumbling knife: 1 – chisels; 2 – ploughshare; 3 – knife.

Calculations performed according to the expression (20) showed that $\alpha_n=30^\circ$. The transverse distance between the blades is equal to the diameter of the cut with two adjacent blades $l_n=10$ cm. The length of the blade should be such that the upper point *D* of the cut (Figure 6) should coincide with the rear end of the front blade, and the lower point *E* with the tip of the lower blade. This prevents the cutting from getting stuck between the blades and increasing the drag resistance. Based on the above, according to Figure 6

$$l_n \leq d_{\kappa\max} \operatorname{ctg}(\gamma - \theta_n). \quad (19)$$

According to the expression (19), the transverse distance between the blades should not be greater than 160 mm. In that case, it should be $l_n=120-140$ mm.

The height of the blade must be less than the maximum radius of the cut (Figure 5), otherwise the possibility of the cut being pinched between the blades increases. Based on this, $h_p=35$ mm.

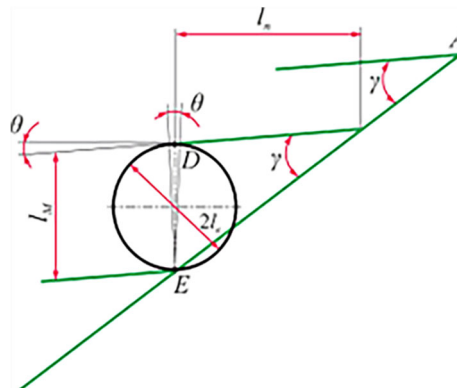

Fig. 5. Scheme for determining the length grinder knife.

The elevation grinder body without lifter was certain according to the following expression [5]

$$H = h_1 + h_2 + a, \quad (20)$$

where h_1 – is the distance from the lower plane of the frame to the covered soil, m; h_2 – the maximum height of compacted soil, m; a – processing depth of the body without a tipper, m.

According to the expression (20), the height of the case without a tipper should be at least $H = 0,42$ m.

4 Conclusions

Analytical dependences for determining the parameters of the elements naval cases are obtained. According results conducted theoretical studies, the level of soil compaction increases when chopper blades are installed in the body without a tipper. The coverage width of the body without a grinder blade is 0.45 m, the corner of input of knife in land is 25°, the nook installation relatively to course of shift is 42°, installation is 35° comparative to the bilge of the sheet, the item of grinder edges is 4, the level is 35 mm, the length is 120-140 mm, the movement high-quality soil treatment is ensured when corner of equipment respective to the direction is 10°, the angle of installation relative clauses aquifer is 30°, and level of the body without the grinder blade lifter is 420 mm.

References

1. F. Maiviatov, F. Karshiev, Sh. Gapparov, IOP Conf. Series: Earth and Environmental Science **868**, 012060 (2021)
2. F. Maiviatov, K. Ravshanov, S. Mamatov, I. Temirov, D. Kuvvatov, A. Abdullayev, IOP Conf. Series: Earth and Environmental Science **868**, 012066 (2021)
3. F. Mamatov, I. Ergashev, B. Mirzaev, X. Pardaev, D. Chorjeva, Journal of Physics: Conference Series **1779**, 012002 (2021)
4. O. Hamroyev, N. Ravshanova, V. Jovliyev, S. Komiljonov, E3S Web of Conferences **264**, 04052 (2021)
5. H. Ravshanov, L. Babajanov, Sh. Kuziev, N. Rashidov, Sh. Kurbanov, IOP Conf. Series: Materials Science and Engineering **883**, 012139 (2021)
6. B. Mirzaev, G. Ergashov, F. Maiviatov, N. Ravshanova, S. Toshtemirov, M. Begimkulova, IOP Conf. Series: Earth and Environmental Science **1076**, 012022 (2022)
7. F. Mamatov, B. Mirzaev, S. Toshtemirov, O. Hamroyev, T. Razzaqov, I. Avazov, IOP Conf. Series: Earth and Environmental Science **939**, 012064 (2021)
8. F. Mamatov, N. Aldoshin, B. Mirzaev, H. Ravshanov, Sh. Kurbanov, N. Rashidov, IOP Conf. Series: Materials Science and Engineering **1030**, 012135 (2021)
9. B. Tulaganov, B. Mirzaev, F. Mamatov, Sh. Yuldashev, N. Rajabov, Khudaykulov, IOP Conf. Series: Earth and Environmental Science **868**, 012062 (2021)
10. F. Mamatov, B. Mirzaev, P. Berdimuratov, M. Aytmuratov, B. Shaymardanov, D. Jumamuratov, IOP Conf. Series: Earth and Environmental Science **868**, 012052 (2021)
11. F. Mamatov, I. Temirov, P. Berdimuratov, A. Mambetsheripova, S. Ochilov, IOP Conf. Series: Earth and Environmental Science **939**, 012066 (2021)

12. B. Mirzaev, F. Mamatov, B. Tulaganov, A. Sadirov, R. Khudayqulov, A. Bozorboev, E3S Web of Conferences **264**, 04033 (2021)
13. B. Mirzaev, B. Steward, F. Mamatov, M. Tekeste, M. Amonov, Annual International Meeting **2100901**, (2021)
14. M. Amonov, B. Steward, B. Mirzaev, F. Mamatov, Annual International Meeting (2021)
15. Z. Shamsutdinov, Sh. Ubaydullaev, N. Shamsutdinov, B. Mirzaev, F. Mamatov, N. Chorshabiyev, IOP Conf. Series: Earth and Environmental Science **614**, 012164 (2020)
16. F. Mamatov, B. Mirzaev, Sh. Mirzahodzhaev, Z. Uzakov, D. Choriyeva, IOP Conf. Series: Materials Science and Engineering **1030**, 012164 (2021)
17. B. J. Ahmedov, B. S. Mirzaev, F. M. Mamatov, D. A. Khodzhaev, M. K. Julliev, InterCarto, InterGIS **26**, (2020)
18. F. Mamatov, I. Ergashev, B. Mirzaev, X. Pardaev, D. Chorlieva, Journal of Physics: Conference Series **1779**, 012002 (2021)
19. F. Mamato, E. Eshdavlatov, A. Suyuno, J Adv Research in Dynamical & Control Systems **12**, (2020)
20. Z. Uzakov, F. Mamatov, O. Begulov, International Conference on information Science and Communications Technologies, Tashkent, Uzbekistan (2019)
21. F. Mamatov, U. Umurzakov, B. Mirzaev, N. Rashidov, G. Eshchanova, I. Avazov, E3S Web of Conferences **264**, 04065 (2021)
22. N. Aldoshin, F. Mamatov, Yu. Kuznetsov, I. Kravchenko, A. Kupreenko, I. Ismailov, L. Kalashnikova, Agricultural Engineering **64**, (2021)
23. F. Mamatov, R. Karimov, R. Gapparov, I. Musurmonov, IOP Conference Series: Earth and Environmental Science **1076(1)**, 012026 (2022)
24. F. Mamatov, R. Karimov, S. Gapparov, R. Choriyev, IOP Conference Series: Earth and Environmental Science **1076(1)**, 012025 (2022)