

Development and numerical simulation of a power plant with a closed-cycle gas turbine running on wood fuel

*Pavel N. Anisimov**, and *Andrey A. Medyakov*

Volga State University of Technology, 3, Lenin Square, Yoshkar-Ola, 424000, Russia

Abstract. The paper presents a number of original technical solutions for a mobile power plant based on a closed cycle gas turbine. The power plant is designed to operate on wood fuel in the conditions of timber warehouses, timber terminals and wood processing industries. The design of a heat generator using wood chips from production waste is proposed. Numerical modelling of the power plant in the SimInTech program was carried out. As a result of mathematical modelling, the main indicators of the power plant were determined. As a result of numerical experiments, the maximum electric power of the power plant was determined to be 1203 kW gross. The optimal initial pressure of the working fluid in the system is determined to be 0.52 MPa under the condition of maximum power. This power was recorded when using a turbine and compressor with a nominal frequency of 1000 Hz, helium as the working fluid of the turbine, combustion products of wood chips with a temperature of 1050 °C in the amount of 11 kg/s, and the use of evaporative cooling. The results obtained can be used in the development of solid fuel power plants with closed cycle gas turbines.

1 Introduction

Efficient use of wood waste as a fuel for generating heat and electricity is an urgent task. The solution of this problem allows to increase the useful use of wood resources and reduce the amount of waste. At present, technologies for burning wood waste to produce only heat are well studied. Less developed technologies for the joint production of heat and electricity on wood fuel in power plants of small and medium capacity. This is an urgent task in modern thermal power engineering, and researchers from many countries deal with these issues [1]. Power plants of small and medium capacity are in demand in the forest complex [2]. They make it possible to provide an autonomous power supply using production waste [3].

This study presents technical solutions for a thermal power plant based on a closed gas turbine cycle. A power plant with an installed electric capacity of 1000-1100 MW, operating on fuel chips, is capable of providing electrical and thermal energy to the equipment of the timber terminal, timber processing industry. The use of technological machines with electric drives together with the proposed power plant can ensure the energy autonomy of production

* Corresponding author: AnisimovPN@list.ru

in the forest complex. When supplemented with an electric energy storage device, a completely autonomous energy supply can be provided in hard-to-reach areas.

2 Modern level of technologies in the field of electricity production based on wood fuel

Currently, the energy use of wood fuel is reduced to two options. First, burning wood in large steam boilers mixed with other fuels or separately to produce power steam. Further, water vapor is used in the heat engine as a working fluid. The advantage of this technology is a sufficiently high energy efficiency for large-scale installations. The disadvantages include: low maneuverability, stationary location of such power plants (lack of mobility), a large amount of equipment, the need for water treatment and circulating water supply, low efficiency of low-power plants. The second option is gasification and pyrolysis of wood and waste. The resulting gaseous and liquid fuel is used in the internal combustion engine. The advantages include the possibility of using internal combustion engines, including transport ones, the possibility of accumulating and transporting synthetic fuel. The disadvantages include lower energy efficiency due to the need for deep purification of gaseous and liquid fuels before use in internal combustion engines. An energy-efficient installation of this type is a complete processing complex.

Power plants for the combined production of heat and electricity based on gas generators, gas mini-turbines of the open cycle, organic Rankine cycle, and solid oxide fuel cells are being developed [4-7]. The positive aspects of the proposed systems are: potentially low emissions of pollutants during operation and combined production of heat and electricity. The disadvantages of these installations are: the complex arrangement of mini-power plants and the high cost, the requirement for deep cleaning of the generator gas. Before using generator gas (synthesis gas) produced from wood for combustion in the combustion chambers of gas turbines, it must be purified in several stages. The same applies to the use of generators in fuel cells. In addition, there are currently no industrial fuel cells operating on generator gas.

Also, research is being carried out on possible technical and economic indicators of combined power plants with gas mini-turbines of external combustion. The advantage of external combustion and closed cycle turbines is the use of a clean turbine working fluid in a closed circuit. The disadvantage is the lower thermodynamic efficiency of a closed cycle compared to open cycle turbines. However, this drawback can be leveled by using gases that are more suitable from the point of view of thermodynamics, for example, helium, as the working fluid of the turbine.

Most of the above studies of promising cogeneration mini-power plants are at the stages of thermodynamic analysis and feasibility studies of technological and technical solutions.

3 Proposed technical solutions for the power plant

For the production of electrical energy based on wet wood fuel, a power plant is proposed, which includes a solid fuel heat generator, a bunker for drying wood chips, a closed-cycle gas turbine plant and other auxiliary equipment. The scheme of the power plant is shown in Figure 1.

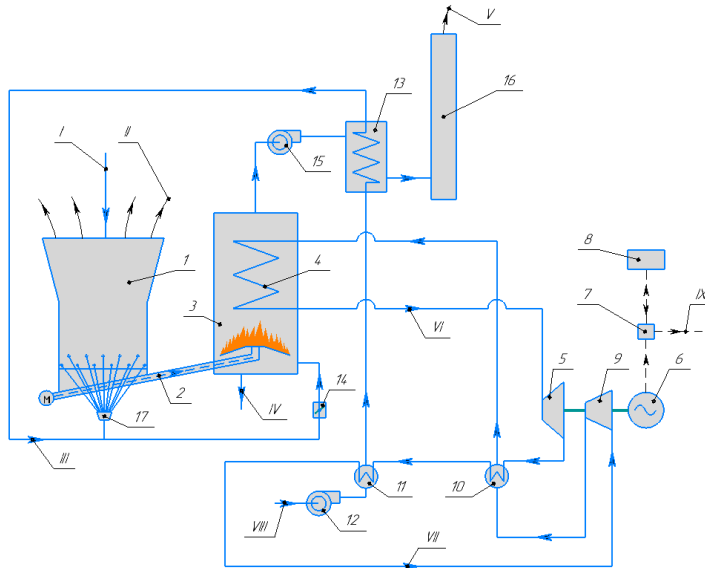

1 - bunker with wood chips; 2 - screw conveyor; 3 – heat generator furnace; 4 – heat generator heater; 5 – gas turbine; 6 - electric generator; 7 – power converter; 8 – electric power accumulator; 9 - compressor; 10 - regenerative heat exchanger; 11 – gas cooler; 12 - air fan; 13 – regenerative air heater; 14 - control damper; 15 - smoke exhauster; 16 - chimney; 17 - air collector; I - supply of wet chips; II - release of moist air into the atmosphere; III - flow of heated air; IV - ash output; V - outgoing flue gases; VI - supply of heated gaseous working fluid of the turbine; VII - cooled working body of the gas turbine; VIII - air supply from the atmosphere; IX - supply of electricity to consumers.

Fig. 1. Scheme of a power plant with a closed cycle wood-fired gas turbine.

The power plant operates as follows. Wood chips are continuously fed to the grate of the heat generator furnace by means of a conveyor. The gaseous products of combustion of wood chips with a temperature of about 1050 °C rise up and enter the heater of the heat generator, where they heat the working fluid of the gas turbine. After that, the combustion products pass through the air heater and are removed into the atmosphere. The gaseous working fluid performs expansion work in the turbine, then the gas passes through the recuperator and cooler. After the cooler, the gas is compressed by a compressor and fed first to the heat exchanger, and then to the heater of the heat generator. Thus, the gas turbine cycle is repeated, and the working fluid circulates in a closed circuit.

The mechanical energy generated by the turbine is distributed to the compressor and electric generator using a common shaft. Electricity from the generator is supplied to the converter and sent to the consumer. Excess heat from flue gases is transferred to atmospheric air by means of an air heater. Hot air is directed to the furnace of the heat generator. Excess hot air is fed into the woodchip bin for drying.

The design of the heat generator is shown in Figures 2 and 3. The heat generator has a vertical cylindrical layout and consists of a furnace and a heater. The heater of the heat generator is a vertical flame tube. Hot flue gases rise through the flame tubes from the bottom to the top. Due to the vertical arrangement of the flame tubes, fly ash will not accumulate inside the tubes. Flame tubes from above and below are fixed in tube sheets. For periodic cleaning of the flame tubes, the upper part of the heat generator is removed and there is free access to the upper tube plate.

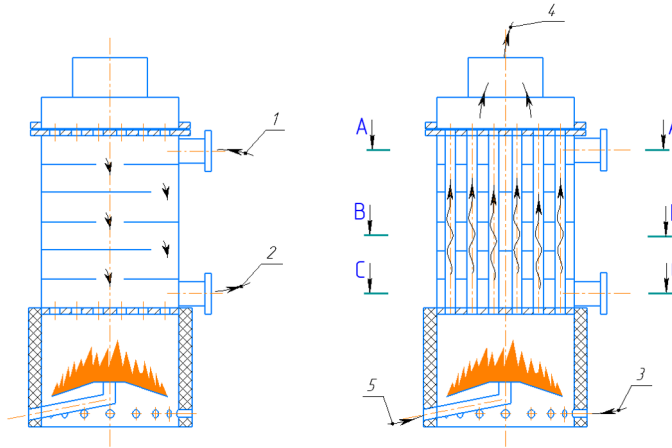

1 - supply of gaseous working fluid from the compressor; 2 - supply of a heated gaseous working fluid to the turbine; 3 - air supply to the furnace; 4 - outgoing flue gases; 5 - fuel supply to the furnace.

Fig. 2. Scheme of the circulation of flows in the heat generator (image in longitudinal section).

The gas is supplied to the annular space, that is, the flame tubes are washed from the outside by the gaseous working fluid of the gas turbine. The trajectory of the movement of the heated gas is perpendicular to the pipes and in a spiral from the periphery to the center and vice versa from the center to the periphery (Figure 3). Thus, a mixed current of the heating and heated coolant is formed in the heat exchanger. Predominantly cross current with counter current. The heated gas enters at the top of the heat generator and exits from its bottom. Thanks to this design, vortex formation and a high heat transfer coefficient are ensured.

Figure 2 shows, for example, 6 strokes of the heated gas flow in the vertical plane, but in fact it is recommended to do more. In the horizontal plane, Figure 3 shows sections of the 1st, 4th and 6th passes. The number of concentric moves in Figure 3 is two, not counting one downstroke. The number of strokes in the horizontal plane can also be increased by increasing the diameter of the heat source.

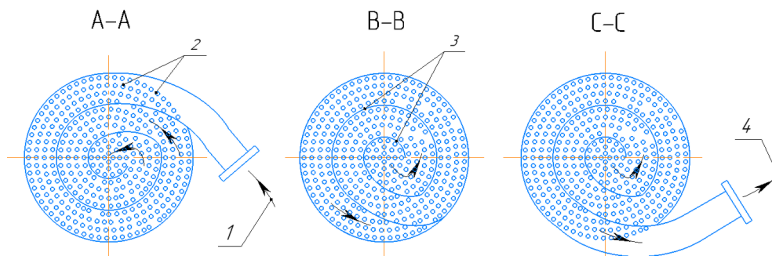

1 - supply of gaseous working fluid from the compressor; 2 - vertical heat exchange pipes; 3 - guide partitions; 4 - supply of a heated gaseous working fluid to the turbine.

Fig. 3. Scheme of the heat exchange part of the heat generator in cross sections.

The operating temperature of the metal of the heat exchange tubes is in the range from 700 to 1050 °C. For their manufacture, a heat-resistant alloy of the KhN78T brand can be used.

4 Results of mathematical modelling in SimInTech

To conduct computational experiments in order to determine the characteristics of the power plant being developed, a mathematical model was created in the environment of dynamic simulation of technical systems SimInTech. The structure of the model is shown in Figure 4, where the heater, recuperator and cooler are submodels.

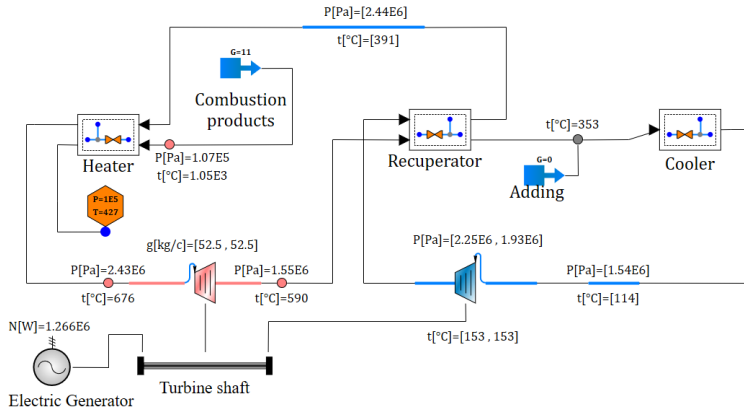

Fig. 4. Graphical representation of the mathematical model in the SimInTech environment.

A series of simulation experiments was performed with different initial pressures of the gas turbine working fluid. Consider the initial parameters embedded in the model. Estimated temperature of wood chips combustion products at the heater inlet is 1050 °C. The mass flow rate of combustion products is 11 kg/s. The wall thickness of the flame tube according to the condition of strength at an operating pressure of 2.5 MPa and an operating temperature of 1000 °C is 3 mm. Helium as a working fluid of a gas turbine. Gas turbine and compressor with a nominal speed of 1000 Hz and an associated power generator. Intensive cooling of the gas turbine working fluid before the compressor using a heat exchanger irrigated with water and blown by atmospheric air - an evaporative cooler. Recuperator with a developed heat exchange surface. Atmospheric air pressure 100,000 Pa and temperature 20 °C.

The results of simulation experiments are shown in the graph of Figure 5. With the above initial parameters of the power plant, the optimal initial pressure of the working fluid of the GTU closed circuit is 0.52 MPa.

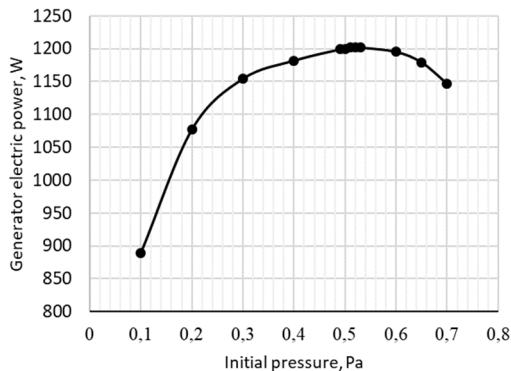

Figure 5. Dependence of the electric power of the generator on the initial pressure of the gas turbine working fluid.

Figure 4 shows the parameters of the working heat and heat carriers of the power plant after reaching the regime at the optimal value of the initial pressure. The maximum mechanical power on the generator shaft is 1266 kW, the maximum electric power of the generator is 1203 kW.

5 Conclusion

The proposed design and technological solutions can be used in the development of power plants based on closed-cycle gas turbines using direct combustion of wood fuel. The created mathematical model can be used for further research and optimization of the system.

References

1. H. A. Ozgoli, H. Ghadamian, M. Pazouki, *Int. J. of Renewable Energy Research* **7**, 1008-1018 (2017)
2. L. J. R. Nunes, T. P. Causer, D. Ciolkosz, *Renewable and Sustainable Energy Reviews* **120**, 109658 (2020)
3. P. N. Anisimov, A. A. Medyakov, *J. Phys.: Conf. Ser.* **1683**, 052015 (2020)
4. M. H. Karimi, N. Chitgar, M. A. Emadi, P. Ahmadi, M. A. Rosen, *Int. J. of Hydrogen Energy* **45**, 6262-6277 (2020)
5. Y. V. Volkova, V. A. Munts, D. B. Choyzonov, N. S. Plotnikov, *MATEC Web of Conferences* **245**, 06004 (2018)
6. Lv. Xiaojing, X. Ding, Y. Weng, *J. Eng. Gas Turbines Power* **141**, 011501 (2019)
7. Z. K. Mehrabadi, F. A. Boyaghchi, *Sustainable Production and Consumption* **26**, 782-804 (2021)