

# Experimental study of the bending of the linter machine saw blade

*Davlat Mukhammadiev\**, *Farhod Ibragimov*, and *Ortiq Abzoirov*

Institute of Mechanics and Seismic Stability of Structures of the Academy of Sciences of the Republic of Uzbekistan, Tashkent, 100125, Uzbekistan

**Abstract.** The article presents the results of an experimental study of the bending of the saw blade of the 5LP linter machine. Therefore, a bench installation was made to conduct an experimental study of the process of the saw blade bending under contact with the ribs. At that, serial gaskets made of AK5M2 aluminum alloy and recommended gaskets of a new design made of St3 steel for the linter machine were used. When modeling the process of saw blades touching the ribs, a load with a bending force of 9.8, 19.6, 34.3 and 49 N is suspended on the maximum diameter of the saw blade. The research results showed that with an increase in bending forces from 9.8 to 49 N, the bending values of the saw blade with an aluminum gasket increase up to 4.5 mm, and with a steel gasket up to 3.5 mm. These results indicate the expediency of using a new design of steel gasket when assembling the saw cylinders of a linter machine, as it increases the bending stability of the saw blades by 28.6% compared to aluminum one AK5M2.

## 1 Introduction

Circular saw blades with an outer diameter of 320 mm, an inner diameter of 61.8 mm, and a thickness of 0.95 mm are mainly used in linter machines produced in existing cotton ginning plants in Uzbekistan.

To increase the durability of the ribs of a saw gin and linter machine, scientific research was conducted. An obligatory condition for achieving the durability of ribs and saw blades is the installation of saw blades in the central part of the gap between the ribs since the contact of the saw teeth with the ribs leads to damage to fibers and lint. Hence, the need for high-quality leveling, hardening of the saw blade teeth, and assembly of saw cylinders appears.

R.M. Kattakhodzhaev [1] studied the influence of the diameter of saw blades on the main parameters of the saw gin. It was determined that with an increase in the diameter of saws up to 400 mm, the density of the raw cotton roller decreases, the productivity of the gin increases, and the number of defects and the amount of impurities in the fiber decrease. It was established [2], that a positive change in the composition of the raw cotton roller occurs due to an increase in its rotation speed, and a decrease in the time the seeds and fibers spend in the raw cotton roller, which leads to a decrease in weight and density of the raw cotton roller.

---

\* Corresponding author: [davlat\\_mm@mail.ru](mailto:davlat_mm@mail.ru)

R. Rakhimova in [3], established the degree of influence of saw geometry on the intensity of fiber separation and its quality indicators. The conducted studies stated the pattern of the teeth interaction along the entire arc of the saw cut; the degree of filling of the tooth cavity with fibrous mass during operation; the role of the density of the raw cotton roller in filling the tooth cavity with fiber and its effect on the performance and quality of the fiber; the gripping ability of saws was studied depending on the geometry and the influence of the density of the raw cotton roller.

In [4], K.M. Islamkulov analyzed the existing methods of heat treatment of saw blades in Russia, the USA, and Germany. A new technology was developed to increase the strength and wear resistance of gin and linter tooth circular saws of cotton gins using existing induction heating units. The effect of nanostructure on the wear resistance of the above products was revealed. The stresses arising during the heat treatment of circular saws were calculated. It was stated that the increase in the wear resistance of circular saws is 2-3 times higher than that of the saws processed by the basic technology. It is recommended to use circular saws made of steel 65G instead of instrument steel U8G.

N.K. Iskandarova and I.G. Shin [5] presented the results of abrasive blasting of the teeth of gin saws; it made it possible, due to the high cutting ability of new abrasive particles - copper slag, to provide an optimal transition surface with a rounding radius that ensures the preservation of the natural properties of cotton fiber. The upper average fiber length was 1.1 mm longer, the specific breaking load 0.55 cN/tex higher, and the elongation at break was 5.3% longer.

Z.A. Shodmonkulov [6] proposed abrasive blasting of the teeth of linter saws, by plastic deformation of the metal during micro-cutting-scratching, and strain hardening, characterized by the depth and degree of hardening, which increases the efficiency of the saws by more than two times compared to the factory-made ones.

In [7], the object of research is the development of a technology for improving the performance properties of cast parts made of steel 45 obtained by electroslag remelt process; the modes of heat treatment of the roll-tooth part in an aqueous water-oil medium were determined to increase the service life of the unit.

Studies conducted by A.G. Kogonovsky [8] have stated that with an increase in the density of the raw cotton roller, the forces acting on the ribs also increase and amount to 25 N at the lowest density, 42 N at the average density, and 60 N at the highest density. This force is sufficient (considering the strength of an individual fiber) for a slight deterioration in the quality of the working surfaces of the teeth of saw blades, ribs, and in some cases for serious damage to the cotton fiber.

According to the results of research conducted by P.A. Rogov and R.Kh. Mustafin [9], it was found that during normal operation of the saw cylinder, a force of 40-45 N acts on each tooth of the saw blade, and this force is uniformly distributed over two adjacent ribs due to the fact that the saw blade is located in the center of the inter-rib gap.

The analysis of the above research data on saw blades showed that they are aimed at quality improving, choosing the rational geometry of saw blades, and the precise assembly of the saw cylinder, etc. As for saw blades, except for attempts to determine the optimal geometry and the teeth hardening, the bending of the saw blade was not studied at the contact with the ribs.

## 2 Materials and methods

In the saw cylinders of the 5LP-160 serial linter machine, gaskets made of AK5M2 aluminum alloy (Figure 1a) are mainly used, installed along the entire length of the shaft between saw blades with a technological pitch of  $8.75 + 0.95 = 9.7$  mm in the amount of 159 pcs, which should be located between the gaps in the ribs [10]. The practice of using existing saw cylinders has shown that the design of the elements of the saw-rib system does not allow obtaining the specified assembly accuracy of both the saw cylinder and the rib, which leads to deviations from spatial coordination.

It takes a lot of time and labor to perform fitting work and to adjust the size of the ribs to the dimensions of the saw cylinder or vice versa; this does not result from the assembly method, but from the deviation from the true dimensions, that is, the accuracy of manufacturing parts such as saw blades, ribs, and saw gaskets. In this case, the inaccurate location of the saw blades relative to the gaps between the ribs leads to saw blades bending, which contributes to the wear of the working areas of the ribs and the teeth of the saw blades.

Therefore, the main reasons for the decrease in the reliability of the working areas of the rib and the teeth of the saw blades are deviations from the true dimensions during the manufacturing of saw blades, ribs, and saw gaskets. To eliminate these shortcomings, a new design of saw blades for linter machines was recommended (Figure 1b) [11].

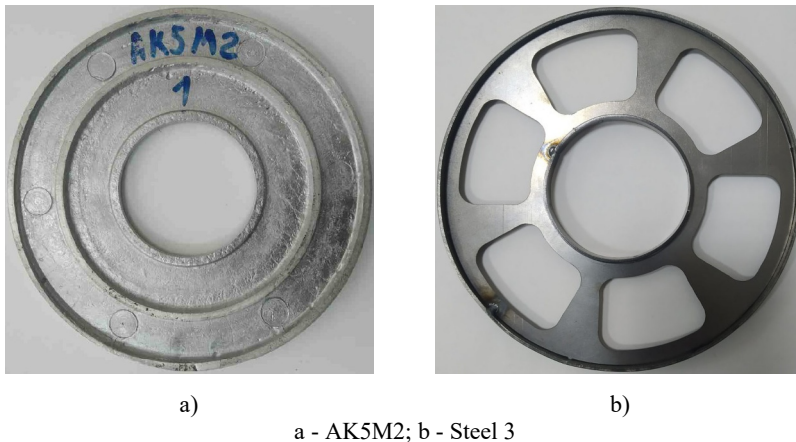

**Fig. 1.** Saw gaskets of the linter machine.

To study the process of saw blade bending, a bench installation was made on the basis of the proposed scheme (Figure 2).

The purpose of the experiment is to study the bending of saw blades when touching the ribs. For this, serial gaskets made of AK5M2 aluminum alloy and recommended gaskets of a new design made of St3 steel for the linter machine were used.

To create a condition for fastening the saw blades on the shaft of the saw cylinder, that is, tightening the gaskets on both sides of the saw blade, a screw mechanical press was used. After tightening the gasket and the saw blade, the changes in the values of dial-type gauges of ICh-10 0.01 brand were measured (Figure 2). To create the process of the saw blade touching the rib, a load of 1, 2, 3.5 and 5 kg is suspended on the maximum diameter of the saw blade, and then the bending force is 9.8, 19.6, 34.3 and 49 N, respectively.

The saw blade, horizontally mounted between two gaskets, is compressed by a screw press. Measurements of the bending value were made using micrometers in the radii of the saw blade  $R=80; 98.75; 117.5; 136.25; 155$  mm. In this case, the bending force is created by a suspension within a radius of  $R=155$  mm. To do this, holes are made in the saw blade where a rod for suspending loads is installed (Figure 2).

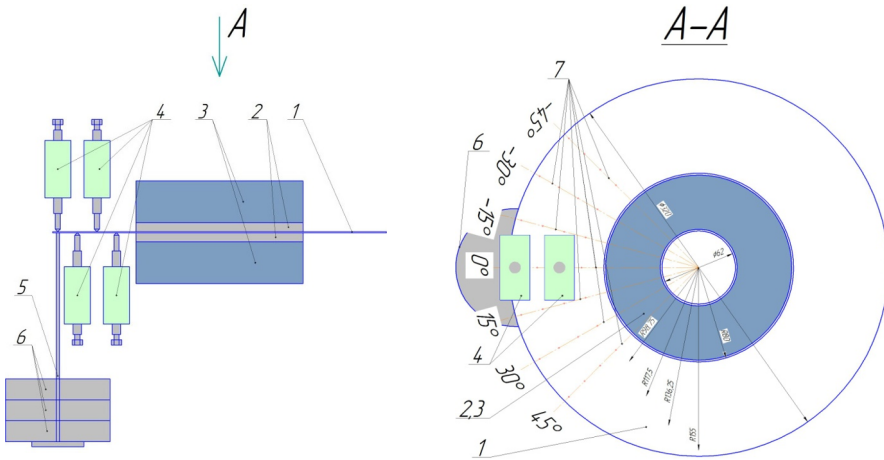

1 - saw blade; 2 - saw gaskets; 3 - mechanical clamp; 4 – dial indicators of ICh-10 brand 0.01; 5 - rod for the load; 6 - load; 7 - sector angles (-45°, -30°, -15°, 0°, 15°, 30°, 45°)

**Fig. 2.** Scheme of the experimental bench for the study of the bending of saw blade.

### 3 Results and discussion

After preparing the bench, experiments were conducted to study the bending of the saw blade in the 90° sector. To compare the bending of saw blades, the gaskets of the linter machine made of aluminum alloy AK5M2 and steel St3 were used (Figures 3 and 4).

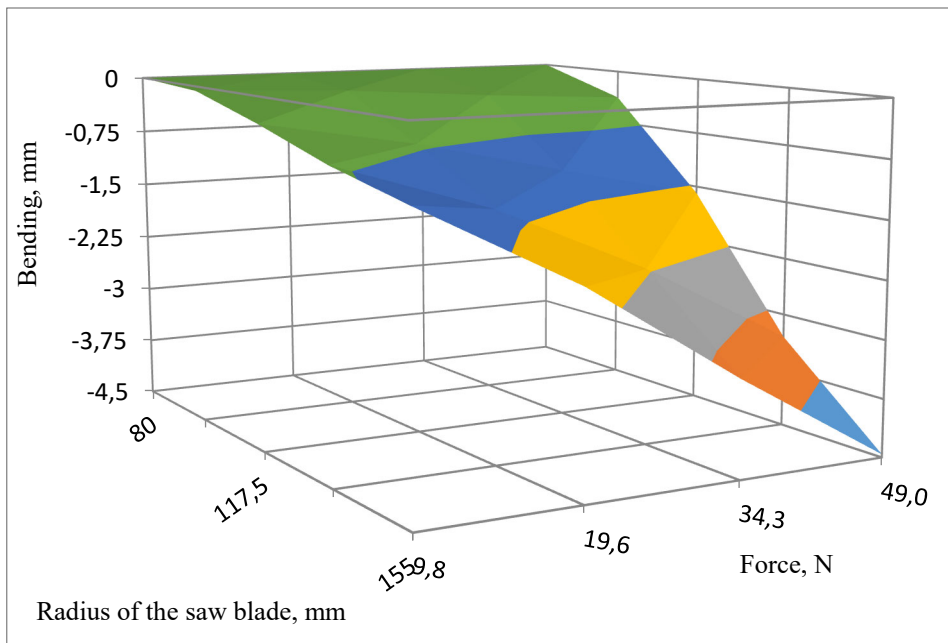

**Fig. 3.** Change in the bending of the saw blade depending on the radius of the saw blade and the bending force with a gasket made of aluminum AK5M2 for the 0° sector.

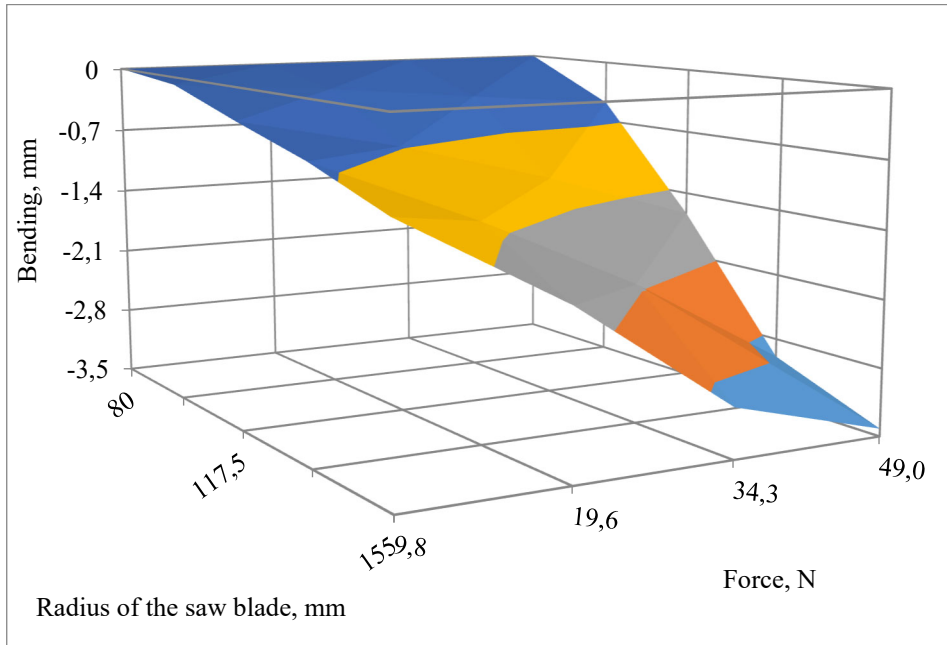

**Fig. 4.** Change in the bending of the saw blade depending on the radius of the saw blade and the bending force with a gasket made of steel St3 for the 0° sector.

Analysis of the results of experiments to study the bending of saw blades (Figures 3 and 4) showed a decrease from 4.5 mm to 3.5 mm when using a steel gasket from St3 relative to aluminum one AK5M2, that is, by 28.6% at a bending force of 49 N.

## 4 Conclusions

The research results (Figures 3 and 4) showed that with an increase in bending forces from 9.8 to 49 N, the bending values of the saw blade with an aluminum gasket increase to 4.5 mm, and with a steel gasket up to 3.5 mm. These results indicate the expediency of using a new design of steel gasket when assembling the saw cylinders of a linter machine since it increases the bending stability of the saw blades by 28.6% more than aluminum one AK5M2.

## References

1. R. M. Kattakhodzhaev, *Study of the influence of increased saw diameters on the main indicators of the ginning process* (Tashkent, 1969), 135
2. A. A. Safarov, E. A. Narmatov, S. Safar, U. Qozoqboyev, A. Bakhridinov, E3S Web of Conferences **258**, 04018 (2021)
3. K. M. Islamkulov, Int. J. of Appl. and Fund. Research **6**, 25-30 (2015)
4. R. Rakhimova, *Investigation of the parameters of gin saws to improve the quality and efficiency of cotton ginning* (Tashkent, 1983), 129
5. N. K. Iskandarova, I. G. Shin, Universum: technical sciences: electron scientific magazine **9(78)** (2020)

6. Z. A. Shodmonkulov *Technological support of the quality of the surface layer under abrasive blasting of the teeth of saw blades of linter machines in order to increase their performance* (Tashkent, 2020)
7. K. Karimov, N. Turakhodjaev, A. Akhmedov, S. Chorshanbiev, E3S Web of Conferences **264**, 04078 (2021)
8. A. G. Kogonovsky, *Study of equipment downtime and substantiation of the planned utilization rate of ginneries equipment* (Tashkent, CNIKHProm, 1952), 102-164
9. P. A. Rogov, R. Kh. Mustafin, *Investigation of the values of lateral pressure saws on the ribs in gins*, Collection of scientific papers TITLP **25**, (Tashkent, 1974), 35-40
10. *Passport of saw linter 5LP* (Tashkent: TGSKB, 1981)
11. D. M. Mukhammadiev, F. Kh. Ibragimov et al., Pat. of the Republic of Uzbekistan No IAP 06691 appl. 12.29.2021 (2021)