

Design and modelling of operational amplifier for energy systems

Sergey Rybalka*, Andrey Demidov, and Evgeny Kulchenkov

Bryansk State Technical University, Physics Department, 50 let Oktyabrya blvd. 7, 241035, Russia

Abstract. In the present study the single channel operational amplifier IS-OU1 with 15 V supply voltage (open loop gain ~100-110 dB) design is based on n-p-n type bipolar transistors has been developed. It is shown that the proposed macromodel sufficiently describes behaviour of operational amplifier. It is established that obtained electrical parameters characteristics of operational amplifier macromodel have good agreement with design requirements. Consequently the proposed design operational amplifier can be applied in industry production for further use in electrical integrated analogue circuits and energy systems.

1 Introduction

It is known that the operational amplifiers are important building blocks of modern electronics and they are used extensively in many industrial applications such as power engineering, energy systems, electrical engineering, machinery control systems etc. [1]. For instance, the use of operational amplifiers in electrical device of electronics of agricultural machinery gives possibility increase the efficiency of agro-industrial complex production and significantly increased the productivity [2].

It is important to note that modern microelectronics produces electronic components in small metal-polymeric packages such as a SOT, QFN and others [1, 3]. In this aspect, in Russia, one of the main tasks in electronics industry is the development of integrated circuits for analogue signal converters in metal-polymer small-sized packages, as well as the development and development of technology and the replacement of imported analogues.

Therefore, within the framework of the import substitution program, Russian electronic company the JSC «GRUPPA KREMNY EL» (Bryansk, Russia) launched the production of new power electronics components (silicon carbide Schottky power diodes, transistors, etc.) in small-sized metal-polymer packages [4]. For instance, in our previous studies it is established that characteristics of the high-voltage silicon carbide Schottky diodes and power silicon bipolar junction transistor made in small type of metalpolymeric packages [4-6] are comparable with the similar leading components types.

Further, to take full advantage of the benefits of amplifiers and ensure the process of introducing new electronic systems, a detailed analysis and evaluation of their characteristics is necessary [1, 3]. It is important to perform a preliminary assessment of various modes of operation of electronic circuits, taking into account the static and dynamic modes of operation

* Corresponding author: sbrybalka@yandex.ru

of operational amplifiers, their operating frequency range, power gain, and circuit stability conditions [1, 3].

In presented study the main goal is the design and macromodel development of single channel operational amplifier, carrying out of simulation and macromodel verification of a main amplifier's characteristics with aim of following serial industry production by «GRUPPA KREMNY EL» in modern small-sized type of metal-polymeric package (SOT-23-5).

2 Materials and methods

In present study the main goal was design macromodel for single channel operational amplifier IS-OU1 with following main characteristics: ± 15 V supply voltage, offset voltage ± 7 mV, low supply current ~ 1.3 mA, slew rate ~ 0.4 V/ μ s, open loop gain ~ 100 -110 dB, gain-bandwidth product ~ 0.7 -1 MHz, output voltage swing ± 14 V. For modelling the operational amplifier with SPICE was chosen nonlinear operation amplifier model is based on n-p-n type bipolar transistors [3, 5]. The equivalent circuit of the operational amplifier is shown in Figure 1. Then parameters for operational amplifier components in circuit were calculated for appropriation with operational amplifier characteristics and written down as subcircuit that is presented in Figure 2. The macromodel can be used as a subcircuit with a .SUBCKT command in Micro-Cap 12 model editor as SPICE circuit program [6, 7] that gives us to obtain a SPICE macromodel of the IS-OU1 operational amplifier. Afterwards for testing of the operational amplifier obtained macromodel was added to Micro-Cap 12 program base as a IS-OU1.lib library file.

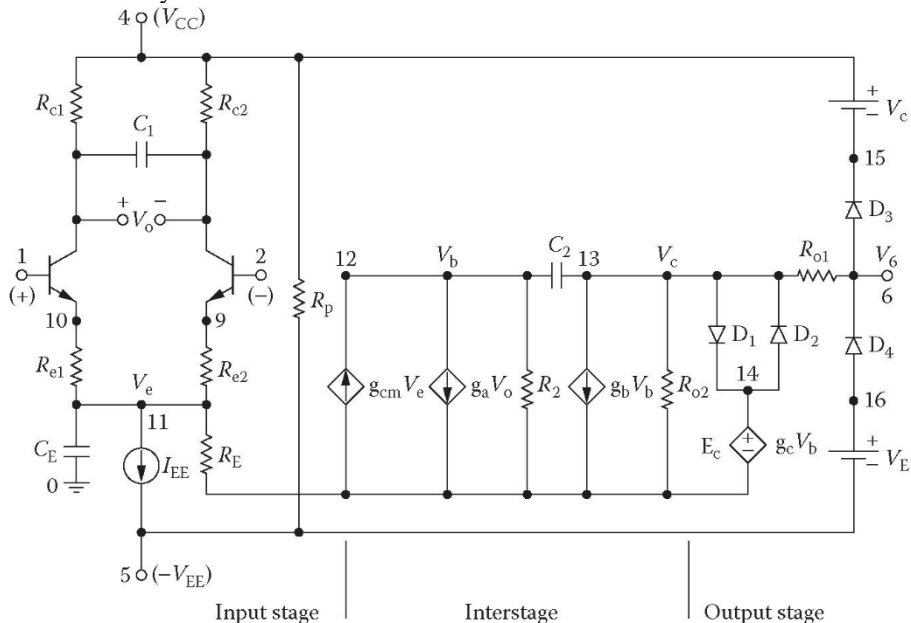

Fig. 1. Circuit diagram of the IS-OU1 operation amplifier of the proposed macromodel [5].

Thus, operational amplifier performance simulation with SPICE [3, 5], which is one of the standard methods used by Micro-Cap 12 circuit designers program [6, 7], will allow initial characterization and performance analysis before assembling a real operational amplifier circuit and bench testing it.

```

* ---- IS-OU1 operational amplifier model subcircuit ----
.subckt IS-OU1 1 2 3 4 5
*
*          | | | | |
*          | | | | | output
*          | | | | | negative power supply
*          | | | | | positive power supply
*          | | | | | inverting input
*          | | | | | non-inverting input
*
c1  11 12 2.8868E-12
c2  6  7 10.000E-12
dc  5 53 dy
de  54 5 dy
dlp 90 91 dx
dln 92 90 dx
dp  4 3 dx
egnd 99 0 poly(2) (3,0) (4,0) 0 .5 .5
fb  7 99 poly(5) vb vc ve vlp vln 0 127.32E6 -1E3 1E3 130E6 -130E6
ga  6 0 11 12 62.832E-6
gcm 0 6 10 99 628.32E-12
iee 10 4 dc 5.0001E-6
hlim 90 0 vlim 1K
q1  11 2 13 qx1
q2  12 1 14 qx2
r2  6 9 100.00E3
rc1 3 11 15.915E3
rc2 3 12 15.915E3
re1 13 10 5.5698E3
re2 14 10 5.5698E3
ree 10 99 40.000E6
ro1 8 5 50
ro2 7 99 25
rp  3 4 36.217E3
vb  9 0 dc 0
vc  3 53 dc 1.7979
ve  54 4 dc 1.7979
vlim 7 8 dc 0
vlp 91 0 dc 20
vln 0 92 dc 20
.model dx D(Is=800.00E-18)
.model dy D(Is=800.00E-18 Rs=1m cjo=10p)
.model qx1 NPN(Is=800.00E-18 Bf=83.333E3)
.model qx2 NPN(Is=800.0000E-18 Bf=83.333E3)
.ends IS-OU1

```

Fig. 2. Text macromodel listing for the IS-OU1 operation amplifier.

3 Results and discussions

The proposed macromodel of operational amplifier then was tested in different modes with aim of model implementation and verification procedure. At first macromodel was tested in buffer (voltage follower) mode which is used to buffer signals by presenting a high input impedance and a low output impedance [5, 8]. As a rule, this circuit is commonly used to drive low-impedance loads, analogue-to-digital converters and buffer reference voltages [1, 3, 8]. In this case the output voltage equals to the input voltage [3, 8, 9].

In Figure 3 is shown testing circuit for testing of SPICE macromodel of operational amplifier in this mode. The operational amplifier was connected to ± 15 V supply voltage and then to non-inverting node was applied signal with amplitude voltage of 14 V (1 MHz the signal frequency, 1 kHz the carrier frequency, 1m Ω the serial resistance).

The input and output characteristics for IS-OU1 operational amplifier are shown in Figure 4. As can be seen, the output swing range of the amplifier obtained by macromodel equals of ± 14 V and therefore requirement is met.

In Figure 5 are shown transient simulation results of amplifier macromodel testing in voltage follower mode. As follows from Figure 5 amplifier demonstrates required mode of operation in buffer mode with voltage amplitude ± 14 V.

Thus, proposed macromodel for IS-OU1 operational amplifier well describes the required characteristics with sufficient accuracy.

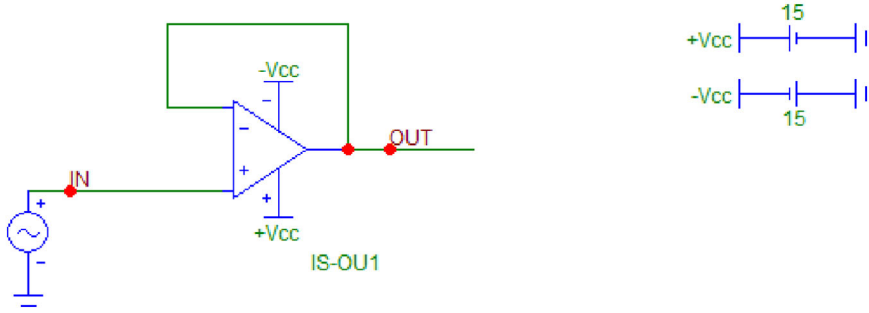

Fig. 3. Circuit for testing of IS-OU1 operational amplifier macromodel in voltage follower mode.

Further, operational amplifier macromodel was tested in inverting amplifier mode where the input signal V_I inverts and applies a signal gain of $-3V/V$ [5, 8].

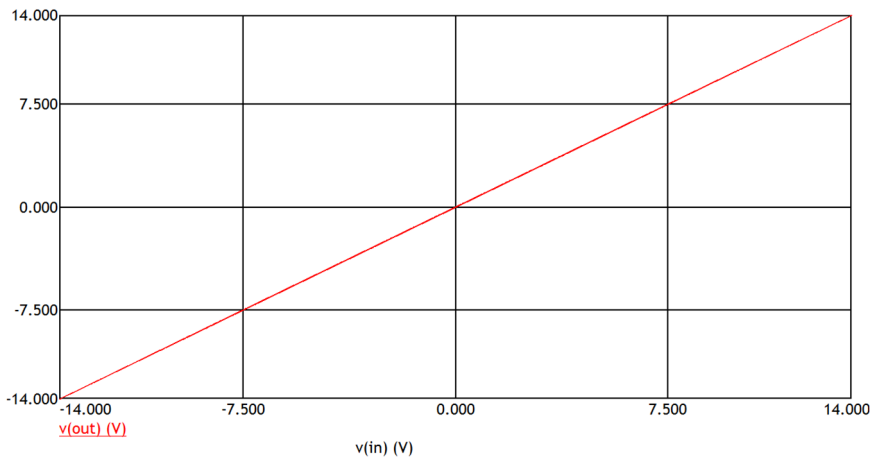

Fig. 4. The input voltage dependence on output voltage for operational amplifier of IS-OU1 in voltage follower mode.

In this case, the input signal typically comes from a low-impedance source because the input impedance of this circuit is determined by the input resistor $R_I=10\text{ k}\Omega$. The common-mode voltage of an inverting amplifier is equal to the voltage connected to the non-inverting node, which is ground in this design.

In accordance with [3, 5, 9] the circuit transfer function is defined by following equation:

$$V_{OUT} = V_I \left(-\frac{R_2}{R_1} \right), \quad (1)$$

where V_{OUT} is output signal voltage, the V_I is the input signal voltage, $R_I=10\text{ k}\Omega$ is the resistor.

Assuming the input signal voltage $V_I=3\text{ V}$ for a desired signal gain G [5, 8] equal of $-3V/V$ calculate R_2 by following equation:

$$R_2 = -GR_1 \quad (2)$$

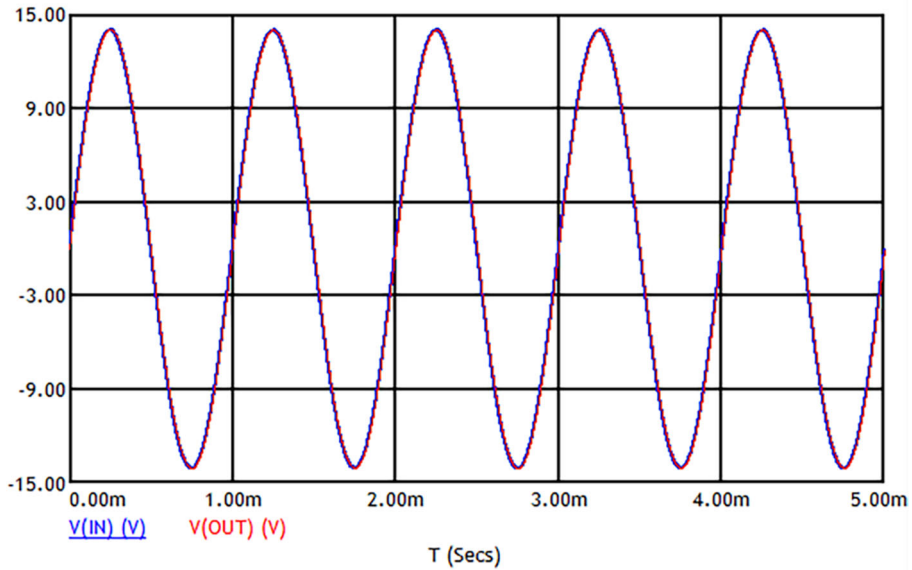

Fig. 5. The input and output voltage depending on time for IS-OU1 operational amplifier in voltage follower mode.

Finally, calculated from equation (1) and (2) value for output signal voltage $V_{OUT}=9\text{ V}$ and value for resistor $R_2=30\text{ k}\Omega$. In Figure 6 is shown testing circuit for testing of operational amplifier macromodel in inverting amplifier mode with $V_I=3\text{ V}$, $R_I=10\text{ k}\Omega$, $R_2=30\text{ k}\Omega$, $R_H=2\text{ k}\Omega$ (load resistance).

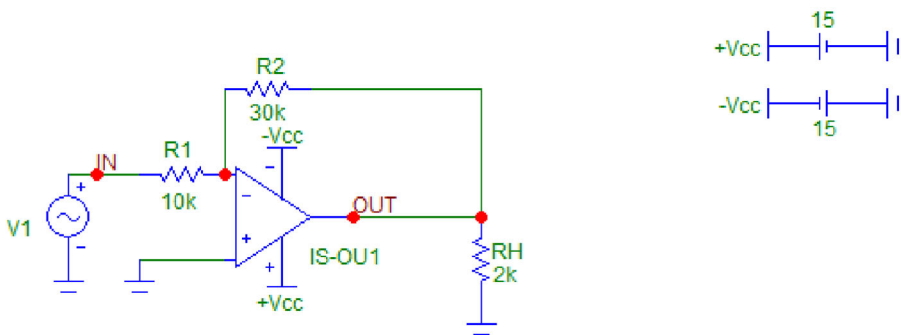

Fig. 6. Circuit for testing of IS-OU1 operational amplifier macromodel in inverting amplifier mode.

Then the IS-OU1 operational amplifier was connected to $\pm 15\text{ V}$ supply voltage and then to inverting node was applied signal with amplitude voltage $V_I=3\text{ V}$ (1 MHz the signal frequency, 1 kHz the carrier frequency, 1 m Ω the serial resistance). Figure 7 presents transient simulation results of amplifier macromodel testing in inverting amplifier.

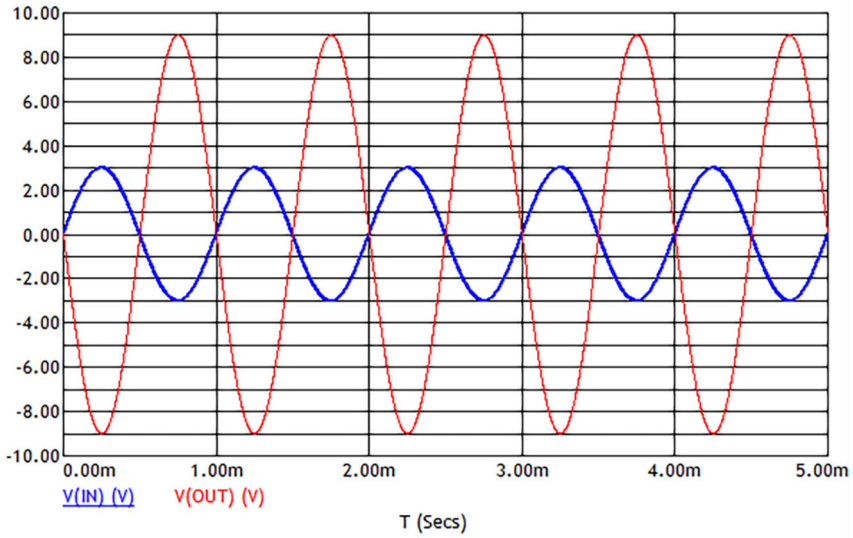

Fig. 7. The input and output voltage depending on time for IS-OU1 operational amplifier in inverting amplifier mode.

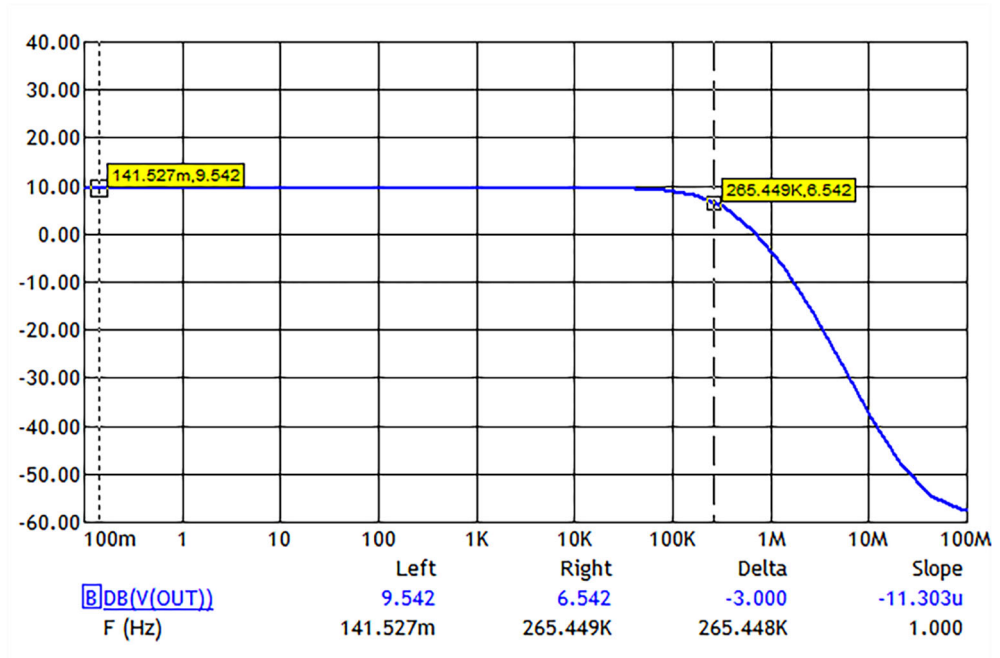

Fig. 8. The voltage gain (dB) depending on frequency (Hz) for IS-OU1 operational amplifier in inverting amplifier mode.

As can be seen from Figure 7 the output voltage (9 V) is three times the magnitude of the input voltage (3 V), and inverted [1, 3, 8]. Thus, the proposed macromodel of amplifier well describes the output and input characteristics with sufficient accuracy. Then calculate the operational amplifiers bandwidth BW for requirement frequency 1kHz. In accordance with [3, 7, 8, 9] BW can be approximated by equation:

$$BW = \frac{GBP}{NG}, \tag{3}$$

where GBP is the gain-bandwidth product (~ 1 MHz), NG is the noise gain that is defined as a $NG=(1+R_2/R_1)=4$.

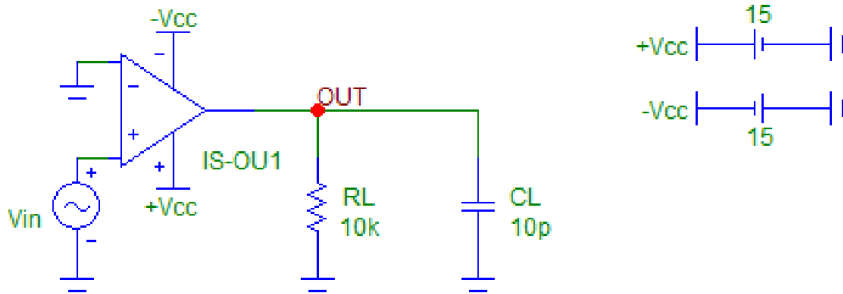

Fig. 9. Circuit for determination of the open loop gain for IS-OU1 operational amplifier.

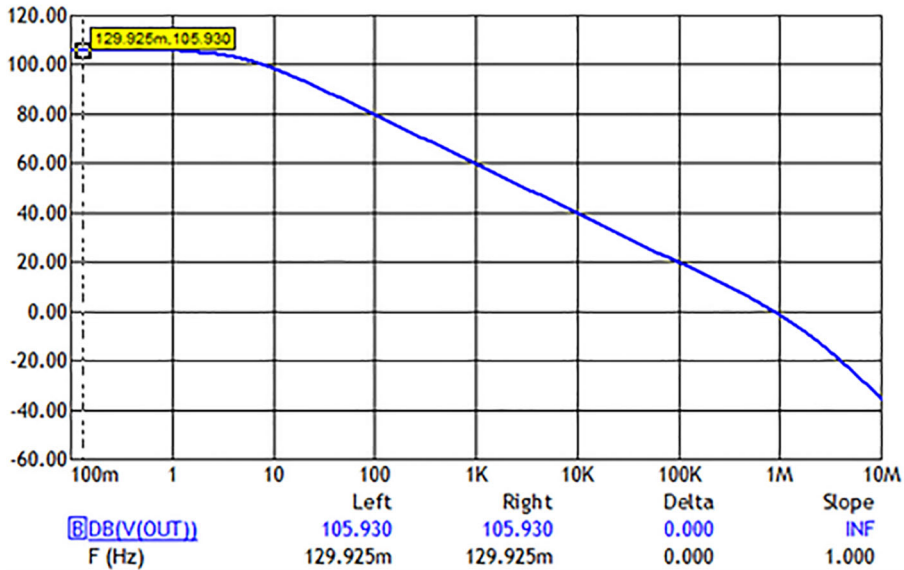

Fig. 10. The open loop gain (dB) depending on frequency (Hz) for IS-OU1 operational amplifier macromodel.

The obtained by equation (3) the amplifiers bandwidth BW equals 275 kHz. From AC simulation results, presented on Figure 8, the bandwidth in accordance with [3, 8, 9] is determined by looking at the 6.542 dB point, which is located at 3 dB given a signal gain of 9.542 dB gives us value of 265.449 kHz. Thus, the modelling result adequately correlates with the determined by equation (3) value of 275 kHz. For determination of the open loop gain for IS-OU1 operational amplifier was created circuit is shown in Figure 9. As can be seen from the Figure 10 the obtained open loop gain value equals ~ 105.9 dB (that is closely acquainted with range (100-110 dB) in proposed macromodel) and unity gain cross frequency value $f_i=859.57$ kHz.

4 Conclusions

In this work a macromodel of an operational amplifier IS-OU1 has been presented. The proposed macromodel is developed using standard algorithm and build-up SPICE techniques for macro-modelling of operational amplifiers with ± 15 V supply voltage and simulates the characteristics, including output voltage swing 14 V, open loop gain ~ 105.9 dB, adequate operation in voltage follower and inverting amplifier modes. The proposed design and model can be used for industry production and processing the test signals and to reduce the computational effort needed for fault simulations in large engineering electrical systems.

This work was carried out with financial support of the Russian Ministry of Science and High Education within the framework of complex project by creation of highly technological industry «Integrated microcircuits of analog signal converters in metal-polymeric package of various types: development and mastering of technology, replacement of imported analogs and organization of serial production» (agreement of 9 February 2023 No. 075-11-2023-008) at the organization of the leading performer of RDDTE (Research and Development Design and Technological Engineering) the Bryansk State Technical University.

References

1. H. Zumbahlen, *Linear circuit design handbook* (Elsevier/Newnes Press, Amsterdam/Boston, 2008)
2. G. Pellizzi, A. Guidobono Cavalchini, M. Lazzari, *Energy Savings in Agricultural Machinery and Mechanization* (Elsevier Applied Science, London, 1988)
3. A. S. Sedra, K. C. Smith, *Microelectronic circuits* (Oxford University Press, Oxford/New York, 2015)
4. S. V. Sedykh, S. B. Rybalka, A. A. Demidov, E. A. Kulchenkov, *J. Phys.: Conf. Ser.* **2086**, 012065 (2021)
5. M. H. Rashid, *SPICE for Power Electronics and Electric Power* (CRC Press/Taylor & Francis Group, Boca Raton, 2001)
6. Spectrum Software - Micro-Cap 12. Analog simulation, mixed mode simulation, and digital simulation software. SPICE and PSpice compatible circuit simulator (2022). <http://www.spectrum-soft.com/index.shtm>
7. M. A. Amelina, S.A. Amelin, *Micro-Cap circuit simulation program. Version 9, 10* (Smolensk branch of NRU MPEI, Smolensk, 2013)
8. S. Yawale, S. Yawale, *Operational Amplifier: Theory and Experiments* (Springer, Singapore, 2021)
9. M. Burns, G.W. Roberts, *An Introduction to Mixed -Signal IC Test and Measurement* (Oxford University Press, New York/Oxford, 2001)