

# Reduced Common Mode Multilevel Inverter Strategy in Photovoltaic Systems

G. Priyanka<sup>1</sup>, J. Surya Kumari<sup>1</sup>, D. Lenine<sup>1\*</sup>, Suresh Kumar Tummala<sup>2</sup>, Hassan Mohammed Al-Jawahry<sup>3</sup>, Harshit Gupta<sup>4</sup>

<sup>1</sup> Department of EEE, RGM College of Engineering and Technology, Nandyal, Andhra Pradesh

<sup>2</sup> Gokaraju Rangaraju Institute of Engineering & Technology, Hyderabad, India

<sup>3</sup> The Islamic University, faculty of Engineering, Najaf, Iraq

<sup>4</sup> Uttaranchal School of Computing Sciences, Uttaranchal University, Dehradun 248007 INDIA

**Abstract:** Now-a-days, non-conventional energy sources are playing a vital role in the generation of electrical energy. This is due to the disadvantages in the conventional sources like pollution, non-availability of the resources, greenhouse effect. Hence more concentration is made by the researcher's on these non-conventional sources so called as renewable energy sources. These renewable sources are used with the converters along with filters to give the best output. In this work, we are focusing on the renewable energy called solar energy and hence the converter is inverter in this case. Basically we have conventional inverters as well as multilevel inverters. Multilevel inverters are basically classified into three types and they are cascaded H-bridge multilevel inverter, diode clamped multilevel inverter, flying capacitor multilevel inverter. Among these cascaded multilevel inverter as many advantages like reduced number of components. This advantage is being used in this work and is simulated by using MATLAB.

## 1. Introduction

In the present industrially society, inverters play a major role and these are conventional. Hence they are replaced by multilevel inverters in the present generation. This beneficiary can be observed in the THD levels of the multilevel inverters in the output waveform, less voltage stresses as the number of components are less. The division of multilevel inverters consists of 1) cascaded multilevel inverter 2) diode clamped multilevel inverter 3) flying capacitor multilevel inverter. Among these topologies cascaded multilevel inverters are being focused by the researchers because of its advantages. This cascaded multilevel inverter is given multiple sources and also the system requires no capacitor which reduces the complexity of the proposed circuit and the cost is minimized. This topology also has advantage of having less THD value.

This proposed circuit topology is given solar energy as the input. Solar energy is the renewable energy source from the sun which has the capability of providing enough energy to the world per annum. This solar energy from the sun is capable of producing heat from

---

\* Corresponding Author: [lenine.eee@gmail.com](mailto:lenine.eee@gmail.com)

which the electrical power can be generated in the solar panels often called as PV panels. These use the principle of photovoltaic effect for the power generation. The panels can be connected either in series or parallel depending upon our rated values. Series connection helps for the improvement of voltage levels and parallel combination of PV panels helps in increasing the current levels.

PWM is a technique that is used to reduce the total harmonic distortion of the load and also the most important technique to vary the frequency and voltage levels of the multilevel inverter. The different types of PWM technique for the multilevel inverters are sinusoidal pulse width modulation (SPWM), space vector pulse width modulation, and selective harmonic elimination pulse width modulation. In the proposed work we are using the SPWM technique for pulse generation to the cascaded H- bridge multilevel inverter.

## 2. Modeling of Solar Cell

The use of renewable energy sources has increased due to its advantages and among them solar energy usage has increased drastically because of its abundant availability and it is not harming the ecosystem. Hence this solar energy by using solar panel is converted into electrical power by a method of principle called photovoltaic effect. Hence it is necessary to model a solar panel and this is done by using MATLAB.

The equivalent circuit of a solar cell is shown in the fig.1 solar cell is the smallest block in the solar panel which consists of a P-N junction in which the light energy is converted into electrical energy. The following are the parameters which are present in the solar cell -  $R_s$  : it is the series resistance in the P-N junction,  $R_{sh}$ : shunt resistance ,  $I_D$ : current passing through the diode,  $I_{sh}$ : shunt leakage current,  $I_L$ : light developed current.

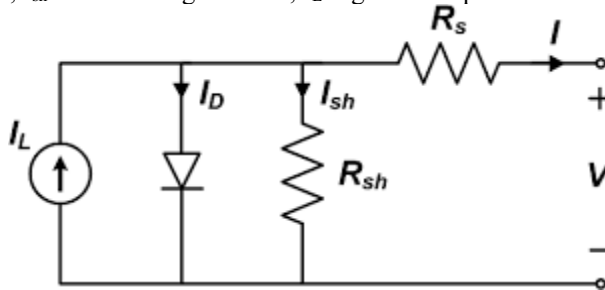

**Fig.1:** equivalent circuit of a solar cell

Basically the output voltage of a solar cell is 0.6V approx. Hence to increase the output power levels we are going for series-parallel combination of the solar cells. These solar cells forms a group known as solar modules and the group of solar modules is called as solar array or solar panel. The expression of solar cell is given by the Eqn. (1)

$$I_{pv} = I_{ph} - I_0 \left[ \exp \frac{qV_{pv}}{NKT} - 1 \right] \tag{1}$$

## 3. I-V and P-V Characteristics of Solar Cell

The I-V and P-V characteristics of a solar cell is shown in the below fig.2. The modeling of the solar cell in this work is carried out at 1000w/m<sup>2</sup> of irradiance and at a temperature of 25°C. These are the standard test conditions. At these values we are able to get the characteristics of solar cell.

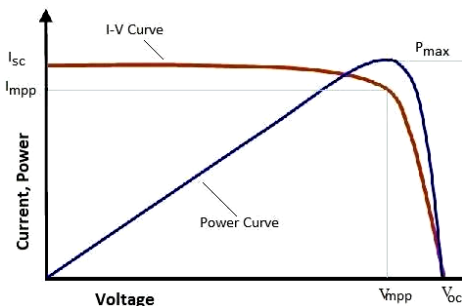

**Fig.2:** IV &PV characteristics of a solar cell

### 4. Proposed Multilevel Inverter

Power electronic converters play a major role for connecting the renewable energy sources to the grid. This work utilizes a power converter called inverter which is used to convert DC source power from the solar cell to AC power. The inverter is so called as cascaded H-bridge multilevel inverter which gives a total output voltage in 9 levels. As it is a cascaded inverter, two bridge circuits are used to produce 9-levels, five from each inverter. The following is the circuit configuration of the proposed multilevel inverter.

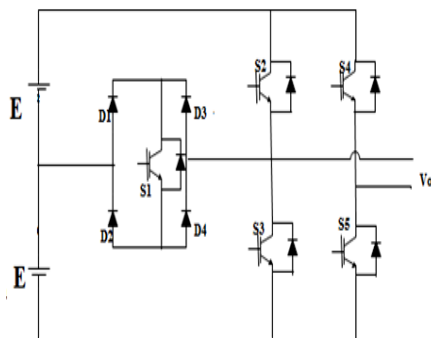

**Fig.3:** Proposed circuit topology of 5-level cascaded inverter

It consists of four switches and four diodes. Based on its principle of operation it gives five levels of output and they are  $2E, E, 0, -E, -2E$ .

**Table.1:** Switching Sequence

Switching Sequence*					Output voltage( $V_o$ )
S1	S2	S3	S4	S5	
0	1	0	0	1	$2E$
1	0	0	0	1	$E$
0	0	0	0	0	$0$
1	0	0	1	0	$-E$
0	0	1	1	0	$-2E$

\*(switch ON = 1, switch OFF = 0)

Two such H-bridge inverters are cascaded together to form the required proposed topology and the circuit is as shown in the below fig. and this is the 9-level topology. This produces the nine output levels of voltage and they are  $4E, 3E, 2E, E, 0, -E, -2E, -3E, -4E$ . Since

each of the terminals in the output of the inverter is connected in series; the output voltage will be obtained by adding the terminal voltages of every inverter.

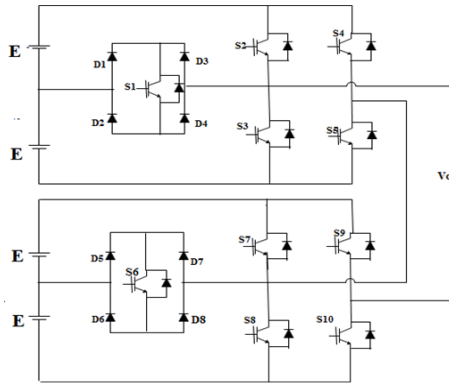

**Fig.4:** Proposed circuit topology of 9-level cascaded inverter

**Table.2:** Working sequence of the proposed circuit

Switching sequence*										Output voltage ( $V_o$ )
S1	S2	S3	S4	S5	S6	S7	S8	S9	S10	
0	1	0	0	1	0	1	0	0	1	4E
1	0	0	0	1	0	1	0	0	1	3E
0	0	0	0	0	0	1	0	0	1	2E
0	0	0	0	0	1	0	0	0	1	E
0	0	0	0	0	0	0	0	0	0	0
0	0	0	0	0	1	0	0	1	0	-E
0	0	0	0	0	0	0	1	1	0	-3E
1	0	0	1	0	0	0	1	1	0	-2E
0	0	1	1	0	0	0	1	1	0	-4E

\*(switch ON = 1, switch OFF = 0)

## 5. Results and Discussion:

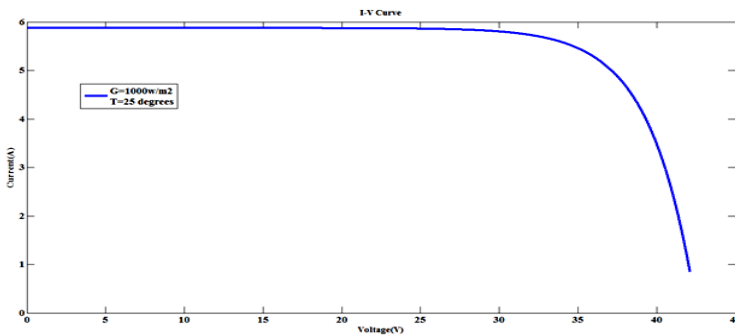

**Fig.5:** IV characteristics of the simulated solar cell

The proposed work is being simulated in the MATLAB. For the working of the switches, pulses are been generated by using the method of PWM technique and in this work sinusoidal PWM technique is being carried out. The solar cell is given the inputs as

temperature =25°C and the irradiance as 1000w/m<sup>2</sup>. The IV and PV characteristics are shown in the below figures. And this is given as input to the cascaded multilevel inverter. This is a 9- level inverter and the output of the inverter is observed at different modulation index. As the modulation index decreases the number of output levels also decreases and these are given in the figures 5 & 6.

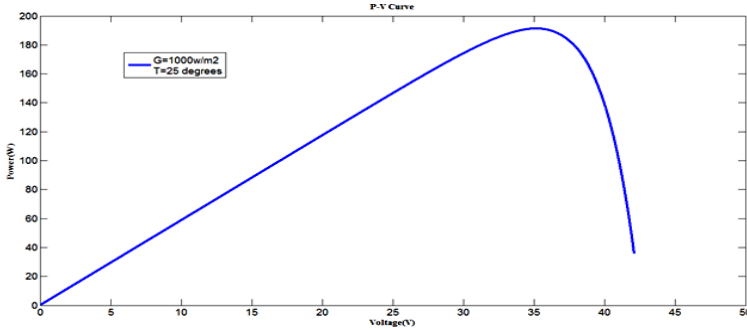

**Fig.6:** PV characteristics of the simulated solar cell

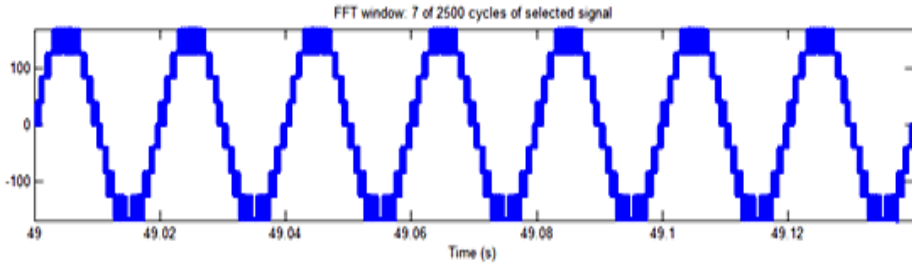

**Fig.7:** 9-level output voltage at modulation index of M=1

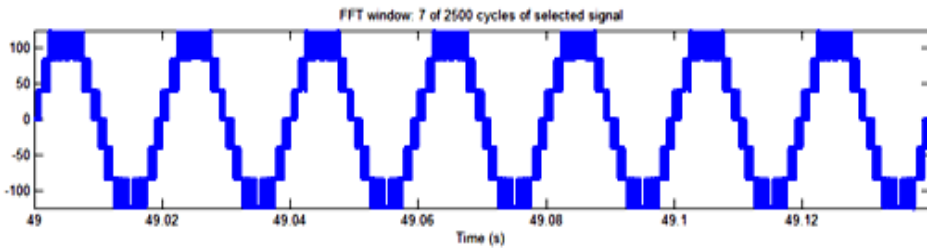

**Fig.8:** 7-level output voltage at modulation index of M=0.75

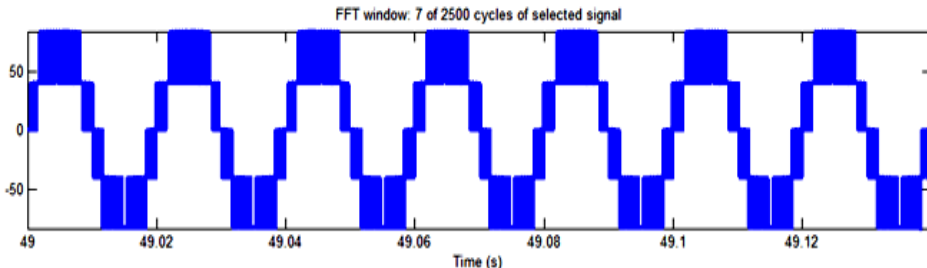

**Fig.9:** 5-level output voltage at modulation index of M=0.5

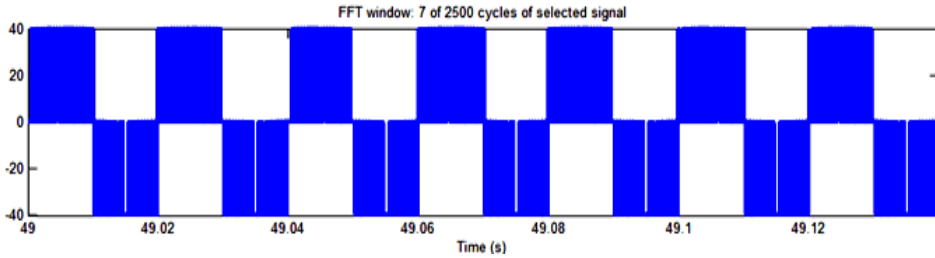

**Fig.10:** 3-level output voltage at modulation index of  $M=0.25$

## 6. Conclusions.

In this work, a nine-level cascaded multilevel inverter is simulated with solar array as the input DC source. Sinusoidal pulse width modulation (SPWM) technique is used to generate pulses to the switches of the inverter. Results are verified in the MATLAB/SIMULINK. We can observe that cascaded multilevel inverter gives us less THD with lesser number of components and lower voltage stresses. This is the main advantage of the proposed circuit topology.

## 7. References

1. B. S. Naik, Y. Suresh, J. Venkataramanaiah and A. K. Panda, "A Hybrid Nine-level Inverter Topology with Boosting Capability and Reduced Component Count," in *IEEE Transactions on Circuits and Systems I I: Express Briefs*, 1-1, 29 May, (2020).
2. R. T. Paul, J. Paul, S. George, S. B and K. Vinod, "Modified three phase Multilevel Inverter with Reduced Number of DC Sources and Switches," 2019 2nd International Conference on Intelligent Computing, Instrumentation and Control 1674-1679, Kannur, Kerala, India, (2019).
3. M. Kavitha, P. B. Bobba and D. Prasad, "Effect of coil geometry and shielding on wireless power transfer system," 2016 IEEE 7th Power India International Conference (PIICON), Bikaner, India, 2016, pp. 1-6,
4. K. P. Panda, S. S. Lee, and G. Panda, "Reduced Switch Cascaded Multilevel Inverter with New Selective Harmonic Elimination Control for Standalone Renewable Energy System," in *IEEE Trans on Industry Appli*, vol. 55, no. 6, pp. 7561-7574, (2019).
5. Siddique, M. D., Mekhilef, S., Shah, N. M., & Memon, M. A., "Optimal Design of a New Cascaded Multilevel Inverter Topology with Reduced Switch Count," *IEEE Access*, (2019)
6. B. J. Varghese, P. B. Bobba and M. Kavitha, "Effects of coil misalignment in a four coil implantable wireless power transfer system," 2016 IEEE 7th Power India International Conference (PIICON), Bikaner, India, 2016
7. A. S. Mohamad, N. Mariun, N. Sulaiman and M. A. M. Radzi, "A new cascaded multilevel inverter topology with minimum number of conducting switches," 2014 IEEE Innovative Smart Grid Technologies - Asia (ISGTASIA), pp.164-169, Kuala Lumpur, (2014).
8. K. Thakre, K. B. Mohanty, H. Ahmed and A. K. Nayak, "Modified Cascaded Multilevel Inverter with Reduced Component Count," 14<sup>th</sup> IEEE India Council International Conference (INDICON), Roorkee, 2017, pp. 1-5, (2017).
9. Farhan A. Salem, "Modeling and Simulation issues on Photovoltaic systems, for Mechatronics design of solar electric applications", Volume 2, Issue 8, August (2014).

10. Tarak Salmi, "MATLAB/Simulink based modeling of solar photovoltaic cell", *International Journal of Renewable Energy Research*, Vol.2, No.2, (2012).
11. B. J. Varghese and P. B. Bobba, "Design and analysis of a robust system for wirelessly powering implantable devices," 2016 IEEE 1st International Conference on Power Electronics, Intelligent Control and Energy Systems (ICPEICES), Delhi, India, 2016, pp. 1-5,
12. Francisco M. Gonzalez-Longatt, "Model of Photovoltaic Module in Matlab", 2<sup>nd</sup> Congress Iberoamericano and De Estudiantes De Ingenieria Electrica, Electronica Y Computation (2005).
13. Nagarjuna, A., Suresh Kumar, T., Yogeswara Reddy, B., Udaykiran, M., Fifteen level cascaded H-bridge multilevel inverter fed induction motor, *International Journal of Innovative Technology and Exploring Engineering*, 2019, 8(11), pp. 640–645.
14. Ami Shukla, "Modeling and simulation of solar PV Module on MATLAB/ Simulink", *IJRSET*, Vol.4, Issue 1, January (2015).
15. Karthik Rao, R., Bobba, P.B., Suresh Kumar, T., Kosaraju, S., Feasibility analysis of different conducting and insulation materials used in laminated busbars, *Materials Today: Proceedings*, 2019, 26, pp. 3085–3089.