

Home Automation Based on IoT

Dr. G. Karuna^{1*}, *R. P. Ram Kumar*¹, *Rajeshwari Kapse*², *Swathi Revulagadda*²

¹Department of AIMLE, GRIET, Hyderabad, Telangana

²UG Student, Department of CSBS, GRIET, Hyderabad, Telangana

Abstract. The next iteration of the internet is called the Internet of Things (IoT). The internet of things (IoT) describes the hardware parts that are connected and talk to one another over the internet. Automation technology is an additional advantage of IoT. Life has gotten simpler and more open-ended thanks to improvements in automation technologies. Since there are more people using the internet than ever before thanks to recent technological advancements, everyone's life is now completely surrounded by it. Wireless Home Automation using IoT is a system that uses mobile or computers to control the components of the home. By enabling customers to control appliances anywhere in the world, home automation sets itself apart from other solutions.

1 Introduction

Home automation system automatically controls of household appliances. Home automation systems uses various microcontrollers and multiple parameters to monitor and control household appliances. IoT sensors and other communication devices are used, which can control home appliances effectively. We can control home appliances from anywhere in the world by using a mobile device, a laptop, or the internet. The system can control various tube lights, fans, household appliances, electrical motors, air conditioners, and air heating systems, among other things, and is easily accessed by web- or internet-enabled devices. Because they can be implemented more affordably and offer flexible functionality that everyone can easily customize in accordance with their needs, these IoT systems are in high demand and have a lot of value. This system architecture includes a suggested system model that uses the Internet to connect, communicate, and coordinate a variety of communication devices for a home automation system. This two Node MCUs are present in the suggested approach. Node Micro Controller Unit (NodeMCU) is an open-source device that combines hardware and software to create a very affordable system based on the ESP8266 chip.

2 Literature survey

With the increase in automation technology, life is becoming more straightforward and effortless. In today's busy world, automation is preferred over manual systems. With increasing numbers of internet users, the internet has become an integral part of everyone's life. Automated homes are yet another new buzz of the internet, and computerized homes are

* Corresponding author: karuna.g@griet.ac.in

easier to handle than traditional homes. The automated home uses a wireless sensor network and biometric technology. Biometric technology employs the authentication of home entrances which enhances the home's security using a private cloud. A lot of other smart home designs estimate only some of the system's cost in addition to describing its structure and analyzing the communications it incorporates.

The Internet of things provides an easier and more effective way to handle the home. Home automation is a new technology employed in traditional homes that make life easier and homes easily manageable. Remote control of lights, fans, and other home appliances. A computer or mobile-based home automation developed to control remote devices. Android software that is connected to home appliances is used as a medium to maintain home appliances.

The authors made a smart home system that can control and manage home appliances. Because they can be controlled remotely from anywhere in the world, smart homes do away with the need for manual control. The proposed system contains servers, actuators, sensors, and microcontrollers. The proposed system helps manage the home without humans' physical interaction with the home by controlling gas leakage, water leakage, fans on & off, etc.

The Internet of things is a fast-developing disruptive technology rapidly changing how people spend their everyday life. After the internet revolution, the internet has become an integral part of everyone's life. IoT is used in the security of homes. A smart IR sensor is placed at the entrance of the building and is used to detect the motion of obstacles. The signal is sent to detect the presence of any block. The owner may or may not be present in the home; the notification, or an email, is sent to the owner. Under home automation, all home appliances are connected through sensors to the mobile application. The mobile application is used to control home appliances from any part of the world.

3 Proposed method

A server, actuators, sensors, and microcontrollers are the most important equipment that make up the proposed model of the home automation system. The configured back-end server will be in charge of managing and keeping an eye on the sensor devices. The proposed model of home automation system will be remotely controllable over the Internet using wireless communication tools like smartphones, tablets, and other wireless devices. The proposed home automation system will manage and control the air conditioning system, fans that turn on and off automatically, lights that turn on and off automatically, sensors that automatically detect gas leaks, and other devices. It will also regulate and control the room's temperature. The proposed home automation system uses IoT-connected communication devices to monitor and regulate gas leakage, fan on/off, light on/off, room temperature, and humidity levels. The NodeMCU is the system's central processing unit and controls numerous home appliance-related operations. To collect real-time data for a home automation system, NodeMCU connects and communicates with various sensors. The user ultimately saw the visibility results after this data and information were sent to the Internet.

4 Implementation

Numerous sensors will be installed throughout the proposed home automation system to collect data and transmit it to the central microprocessor. The home automation system uses a variety of sensor devices to sense, communicate with, and collect data from numerous appliances. Microprocessors receive real-time data from the sensors, which are continuously gathering it. The microprocessor contains a code that automatically controls home appliances like fans, tube lights, doors etc. Additionally, it can monitor these appliances remotely, notify

the user when a problem develops, and cloud-storing the information it gathers. Users can view the outcomes and make decisions after the actual data processing has taken place in the cloud. The sensor devices are also connected to various NodeMCU ports.

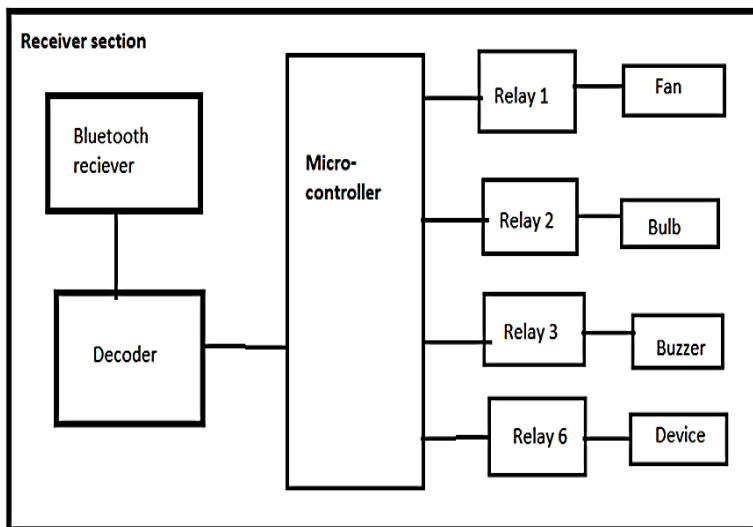

Fig. 1. Block diagram.

4.1 Modules of home automation system

4.1.1 Module 1 of the data collection unit

Sensors for home automation systems are included in this data collection unit module. The data such as environmental conditions of specific room in which the system is implemented are gathered through various sensors connected, which can communicate with each other. They then display this information to a third-party server, such as *thingier.io* (to monitor and visualize the data), and send it to the microprocessors so the processors can decide what action to take next based on the data.

- Humidity and Temperature Sensor (DHT11): Digital temperature and humidity sensors with a low price tag include the DHT11. A resistive component is used to measure the environment in the DHT11 sensor, which also includes a humidity captivating sensor and a thermostat element. The sense produces an output that can be understood by us or other means and is connected to a microcontroller with high performance.
- Light Dependent Resistor (LDR): It is also referred to as a "photoresistor" because it uses electromagnetic radiation's incident resistivity as a source of power. They are consequently light-sensitive technology. The semiconductor material is the primary component used to make LDRs. Due to the characteristics of photoconductive materials, when light is loaded into a resistor, the resistance naturally and decreases with respect to time.
- Grove Gas Sensor (MQ-2): It is a model of a gas sensor with a useful option for spotting gas leaks in residences. The sensor is capable of in-time, fast response detection of a variety of gasses, including H₂, LPG, CH₄, and CO. Additionally, the measurements will be made quickly to ensure accuracy. Sensitivity varies according to the potentiometer.

4.1.2 Central processing unit module II

Two NodeMCUs that will function by providing sensor in and out connections are contained in the aforementioned designed module. A popular open-source platform for the creation of IoT applications is Node MCU. Its hardware is based on the ESP-12 module, and its Wi-Fi SoC is the ESP8266. In most cases, the firmware—not the development kit—is referred to as the Node MCU. The Lua scripting language is the foundation of the Firmware. The ESP8266 is a known Wi-Fi SoC widely used in IoT applications. The purpose of the Arduino IDE is to provide programming language tools for utilizing a variety of libraries and functions to carry out a variety of tasks.

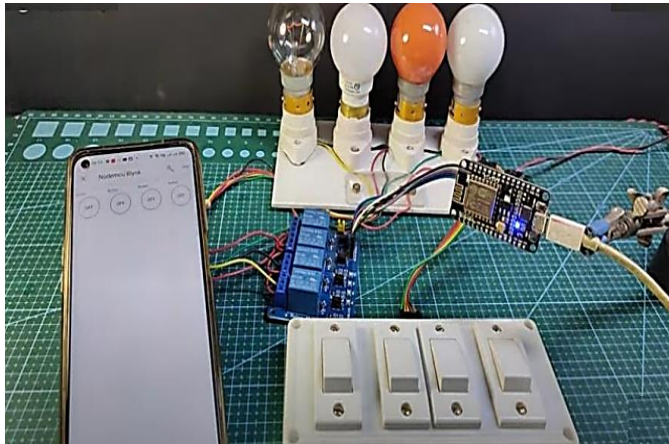

Fig. 2. Real-time experiment of home automation using IoT.

4.1.3 Interface Unit - module III

The user can utilize the functionality of *thinger.io* (it is called *thinger.io*) by using the third-party IoT cloud server that is included in the aforementioned module. A cloud platform called *Thingier.io* offers features like data monitoring, data collection (with free cloud storage for storing the data), and device control.

5 Results and discussions

Home appliances like fans, lights, and air conditioning can all be remotely controlled by a mobile device. From the internet, download the Blynk Android app. It has the ability to operate electrical devices. The operational model, for instance, is that anyone turning on or off a light in their home notifies others via text message to their mobile device. The system will receive a positive output for knowing the results of various appliances connected to the home automation system because all sensors are connected and tested in conjunction with one another. If the room temperature rises above 45 degrees, the temperature sensor will automatically detect it and sound an alarm. The gas and smoke detector sensor will automatically sound a buzzer to alert humans to any unneeded gas leaks in the kitchen, and it will also send an SMS to a mobile device that will display a message indicating whether or not there were any leaks. A room's humidity level will be detected by the humidity sensor, which has a threshold that is by default set to 100. Various unnecessary lights, fans, and air conditioning systems are automatically detected and turned off by the home appliances. These systems turn off automatically when people are not using them to conserve energy and

lower electricity bills. Following the establishment of each connection, it immediately begins to work. When a person enters a room in a house, the system sends a message to their phone to let them know, and then automatically turns on and off the lights, fans, air conditioners, and motors in the room. tors).

6 Conclusion

The proposed automation system is scalable, but when applied on large scale, security issues arises. Appropriate actions should be taken, such as weeping the bell to alert humans, to avoid problems that will occur in their homes. Internet-capable devices can remotely control all household appliances, including lights, fans, refrigerators, and air conditioning systems. The portable internet-enabled device will automatically control the house doors from a distance.

References

1. N. Dickey, D. Banks and S. Sukittanon, *Home automation using Cloud Network and mobile devices*, in the Proceedings of IEEE Southeastcon, Orlando, FL, USA, (2012)
2. Javale, Deepali, *Int. J. of Elect. Comm. and Comp. Tech.* 3, 2, (2013)
3. H. Basil, *Int. J. of Soft Comp. and Eng.* 1, 6, (2012).
4. P. Siva Nagendra Reddy and K. Tharun Kumar Reddy and Praveen Kumar Reddy and G. N. Kodanda Ramaiah and S. Nanda Kishor, *An IoT based home automation using android application*, in the Proceedings of 2016 International Conference on Signal Processing, Communication, Power and Embedded System (SCOPES2016), (2016)
5. K. Baraka, M. Ghobril, S. Malek, R. Kanj and A. Kayssi, *Low cost Arduino/Android-based Energy-Efficient Home Automation System with Smart Task Scheduling*, in the Proceedings of 2013 Fifth International Conference on Computational Intelligence, Communication Systems and Networks, Madrid, Spain, (2013)
6. M. Asadullah and A. Raza, *An overview of home automation systems*, in the Proceedings of the 2016 2nd International Conference on Robotics and Artificial Intelligence (ICRAI), Rawalpindi, Pakistan, (2016)
7. M. A. Bakar, *AIP Conference Proceedings.* **2339**, 1, (2021)
8. V. Subba Rao, T. Mahesh Kumar, N. Santhosh, K. Ramya Laxmi, *Int. J. of Eng. Res. & Tech.*, **9**, 11, (2021)