

Sun Powered Mobility: “Developing A Solar Tracking System For Electric Vehicle Charging”

Srinivasa Rao Jalluri^{1*}, *BhuvanaChandra Kusuma*², *AkhilaSri Narra*³, *PrajweshSunny Seelam*⁴ and *Saketh Veerabathini*⁵

¹ Associate Professor, Department of Electrical and Electronics Engineering, VNR VJIET, Hyderabad, Telangana, India

² UG Student, Department of Electrical and Electronics Engineering, VNR VJIET, Hyderabad, Telangana, India

³ UG Student, Department of Electrical and Electronics Engineering, VNR VJIET, Hyderabad, Telangana, India

⁴ UG Student, Department of Electrical and Electronics Engineering, VNR VJIET, Hyderabad, Telangana, India

⁵ UG Student, Department of Electrical and Electronics Engineering, VNR VJIET, Hyderabad, Telangana, India

Abstract: Sun is the only free source available to the PV module in our area. When the sun shines on a PV cell, solar energy is converted into electrical energy. Today, solar energy is a key component of supplying our energy demands. However, on occasion, this demand cannot be satisfied by solar energy. We use MPPT techniques in those circumstances because they increase power generation and have the key advantage of operating in any environment. It draws the greatest amount of power possible from the available PV unit without depending on any environmental circumstances. These techniques are performed on a boost converter with a battery circuit as a load. This research compares three maximum power tracking methods: perturb and observe (P&O), incremental conductance (IC), and fuzzy logic-based.

I. Introduction

One of the most important renewable energy sources, photovoltaic (PV) generation, has many advantages, including cleanliness, ease of maintenance, and lack of noise. This technology has been used in several applications, including satellite power systems, solar power generation, solar battery charging stations, and solar vehicles (such as cars, ships, and aeroplanes). Some challenges must be overcome when a PV MPPT system is placed in a car in order to get the most power out of the PV panels.

The MPPT is a charge controller that accounts for the fluctuating Voltage Current characteristic of a solar cell. The MPPT tricks the solar panels into producing a variable voltage and current, allowing more power to get into the battery or batteries, even when you are unable to adjust the load. The MPPT establishes the operating point that will supply the

* Corresponding Author: srinivasarao_j@vnrvjiet.in

most power possible to the batteries while monitoring the output voltage and current from the solar panel. If our MPPT can accurately track the operating point, which is always shifting, where the power is at its maximum.

MPPT TECHNIQUES:

The maximum power point (MPP) of the widely used array is necessary for the solar power producing system. Temperature and sun radiation are continually changing; thus it is important to monitor the MPP of solar arrays.

A. PERTURB AND OBSERVE METHOD

Due to its simplicity of usage, the Perturbation and Observation approach has been widely adopted. By adjusting the PV panel output voltage, the P&O algorithm will force the PV system to approach the maximum power point. The P&O algorithm's control flow diagram is shown in Figure(1)

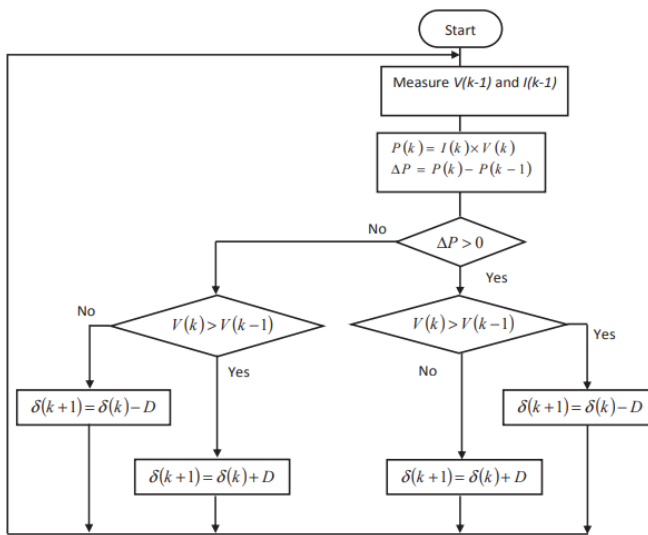

Figure1. Flow chart of P&O method [1]

The P&O approach alters the PV panel's operating voltage to determine the direction change for maximising power; if power increases, the operating voltage is further altered.

If it drops, the direction of the perturbation is reversed, whereas if it increases. Up till the MPP is attained, this procedure is periodically repeated. Later, the system centred itself on the MPP. On the basis of the following relationship, it is possible to determine the duty cycle perturbation at time (t+1):[1]

$$d(t+1) = d(t) + (2\text{Sign} - 1)D \tag{1}$$

Where Sign is given by:

$$\text{Sign} = ([P(t) - P(t-1)] > 0) \oplus ([V(t) - V(t-1)] > 0) \tag{2}$$

B.INCREMENTAL CONDUCTANCE METHOD

Based on the fact that the slope of the PV panel power versus voltage curve is zero at the MPP, positive to the left of the MPP, and negative to the right of the MPP, the incremental conductance (IncCond) approach was developed. The MPPT system describes the link between the instantaneous conductance(I/V) and the incremental conductance ($\Delta I/\Delta V$) given by:

- $[\Delta I/\Delta V] + [I/V] = 0$, at MPP (3)

- $[\Delta I/\Delta V] + [I/V] > 0$, left of MPP (4)

- $[\Delta I/\Delta V] + [I/V] < 0$, right of MPP (5)

- The condition $(\Delta I/\Delta V) + (I/V) = 0$ (6)

is rarely satisfied because to noise, measurement errors, and quantification errors; as a result, in steady state, the system oscillates about the MPP. To address this issue, we add a new parameter, as follows:

- $|\Delta I/\Delta V + I/V| \leq \epsilon$ (7)

- The flowchart picture depicts the IncCond algorithm.

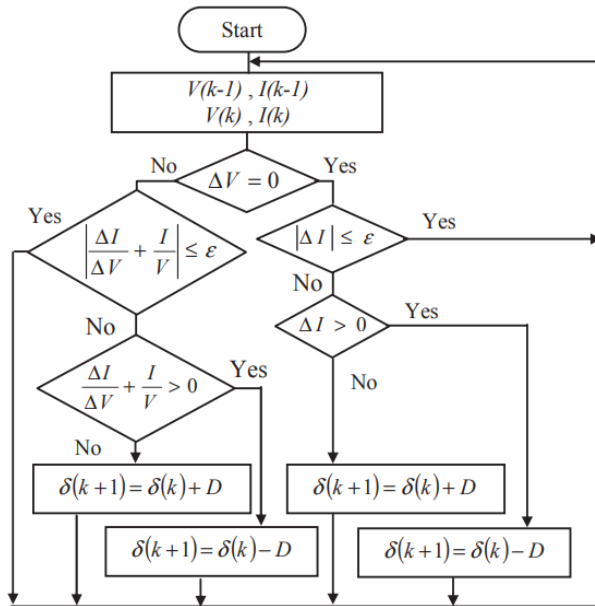

Figure 2. Flowchart of IC method [1]

- The value of I determines how loud the oscillations around the MPP will be. With an increase in ϵ , it declines .

- The operational point diverges from the genuine MPP for a rather high value of ξ , though. For the MPPT system to perform well, the parameter's value must be properly chosen.

C.FUZZY LOGIC

The most major and productive use of fuzzy logic theory has been made possible by advancements in microelectronic technology. Fuzzy logic processors, based on fuzzy logic, offers a mathematical tool for turning (IF-THEN) statements that represent language control rules into an automatic control strategy. [9] [10] [11].

The corresponding change of error CE and error E, which are stated in the formula, are the two inputs of the FLC.

$$\bullet E(k)=[P(k)-P(k-1)]/[V(k)-V(k-1)] \quad (8)$$

$$\bullet CE(k)=E(k)-E(k-1) \quad (9)$$

$P(k)$ and $V(k)$ stand for the PV panel's output power and voltage at sampling instant k , respectively. The scaling factors for the inputs are dP_{pv} and dV_{pv} and the defuzzification gain is gdV_{pv}^* . dV_{pv}^* stands for the result of the fuzzy procedure.

The three functional building elements that make up the fuzzy logic controller are fuzzification, fuzzy rules and inference engine, and defuzzification.

Fuzzification:

Fuzzification, a method used in MPP Tracking with fuzzy logic, is the transformation of crisp input variables, such as PV voltage and current, into fuzzy variables that may be used in a fuzzy logic controller. For a fuzzy logic MPPT algorithm to capture the uncertainty and imprecision related to real-world input variables, fuzzification is a crucial stage in the development process.

The input variable range is divided into several fuzzy sets or membership functions, each of which represents a distinct degree of membership in a certain linguistic variable. As an illustration, the input variable for PV voltage may be fuzzified into language variables like "low," "medium," and "high," each of which would have a set of membership functions that would signify varying degrees of membership.

Fuzzy Rule:

In rule-based systems, fuzzy rules are a particular kind of system. It is possible to reason with ambiguity and imprecision using the mathematical framework of fuzzy logic.

Variables are not given exact values in fuzzy logic; instead, they are given degrees of belonging to a certain set. In complicated systems and phenomena that are challenging to model using conventional logic, this gives representations more flexibility.

In order to indicate the relationships between different variables, a collection of assertions known as fuzzy rules is used. Typically, they take the form of "if-then" statements, where the "if" section indicates the circumstances under which the rule applies and the "then" part provides the outcome or course of action.

In conclusion, a vital element of a fuzzy logic system that enables automated reasoning and decision-making based on fuzzy rules and input data is the inference engine. It mixes the input variables in accordance with the fuzzy rules to provide a crisp output value that can be applied to decision-making or system control.

Defuzzification:

The FLC's crisp output is calculated during the defuzzification process. It explains how to translate a space of fuzzy logic statements that corresponds to the output of an inference into a rigid control action. The most popular defuzzifier, the centre of gravity Defuzzifier, is used in this study. The flow chart for fuzzy logic is in figure

Table 1. Inference Engine Table

$\Delta V_{pv}^*[o/p]$	$\Delta V_{pv}[i/p]$				
	NB	NS	ZE	PS	
NB	PS	PB	NB	NB	
NS	PS	PS	NS	NS	
ZE	ZE	ZE	ZE	ZE	
PS	NS	NS	PS	PS	
PB	NS	NB	PB	PB	

FLOW CHART:

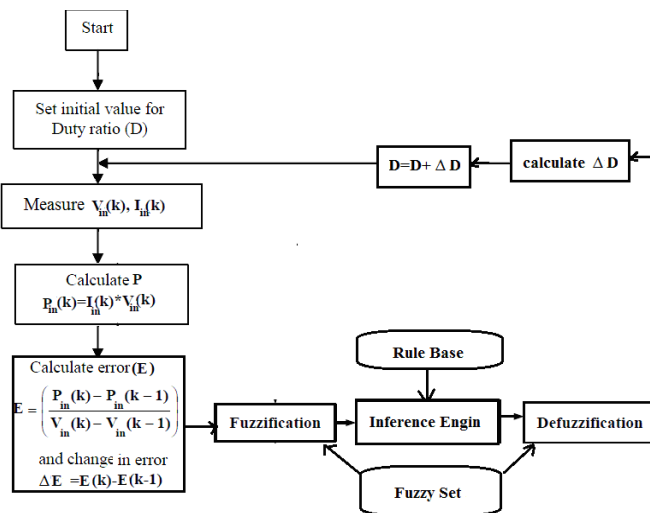

Figure3: Flow chart of Fuzzy logic

The inputs and outputs of fuzzy logic controller are as shown:

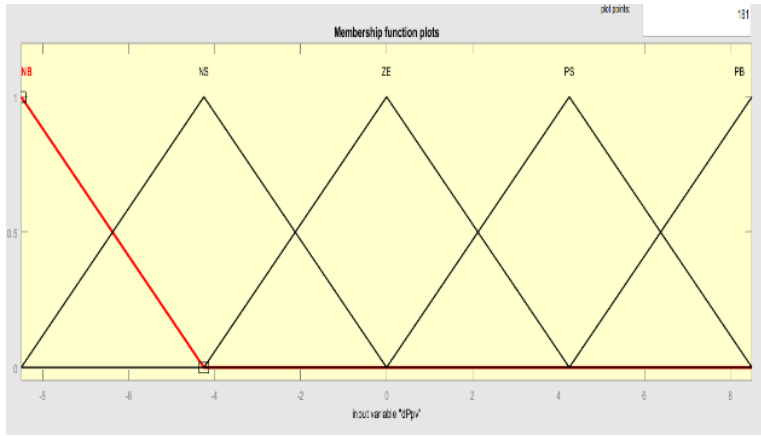

Figure 4: Input 1 dPpv

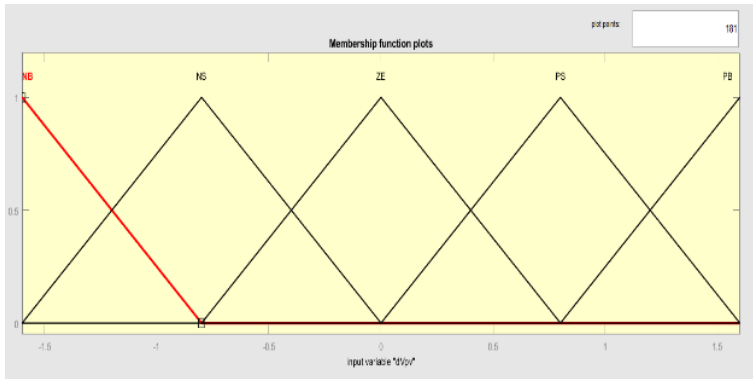

Figure5: Input 2 dVpv

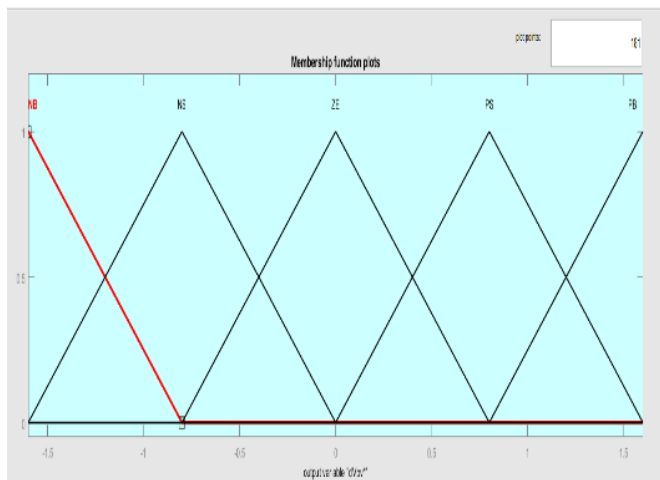

Figure 6: Output dVpv*

2.SOLAR PANEL

A. DESCRIPTION OF SOLAR PANEL

The solar panel used here is Kyocera KC200GT.

A photovoltaic (PV) module called the Kyocera KC200GT is made to produce power from sunshine. The module's specifications are as follows:

- Power output: 200 watts
- Cell type: Polycrystalline silicon
- Cell efficiency: 16%
- Module efficiency: 14.8%
- Dimensions: 65.43 x 39.09 x 1.77 inches (1664 x 992 x 45 mm)
- Weight: 44.1 lbs (20 kg)
- Maximum system voltage: 1000V
- Operating temperature: -40°C to 85°C
- Warranty: 20-year power output warranty, 5-year workmanship warranty

The Kyocera KC200GT module can be used in a variety of solar power systems, including those for homes, businesses, and industries. Its high-efficiency polycrystalline cells are built to produce the most power possible even in low light.

The I-V and P-V characteristics of the respective solar panel are shown below:

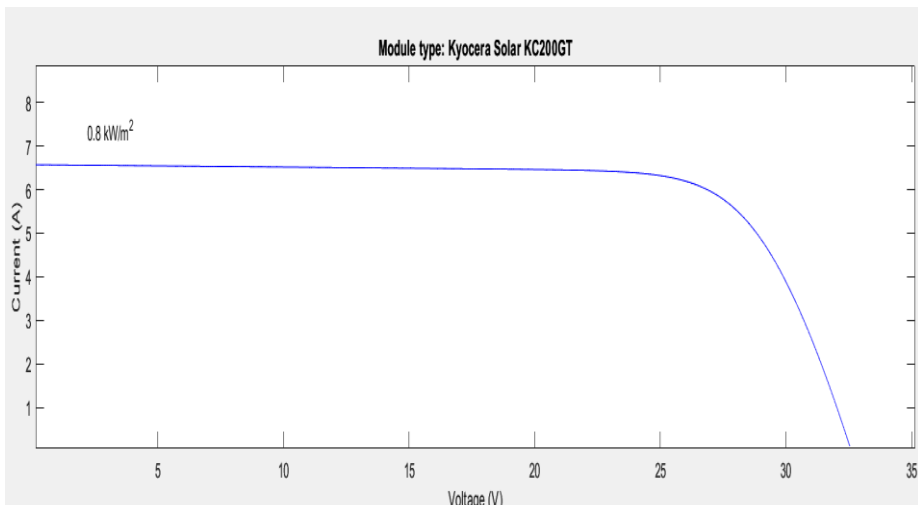

Figure 7: I-V Characteristics of Kyocera Panel

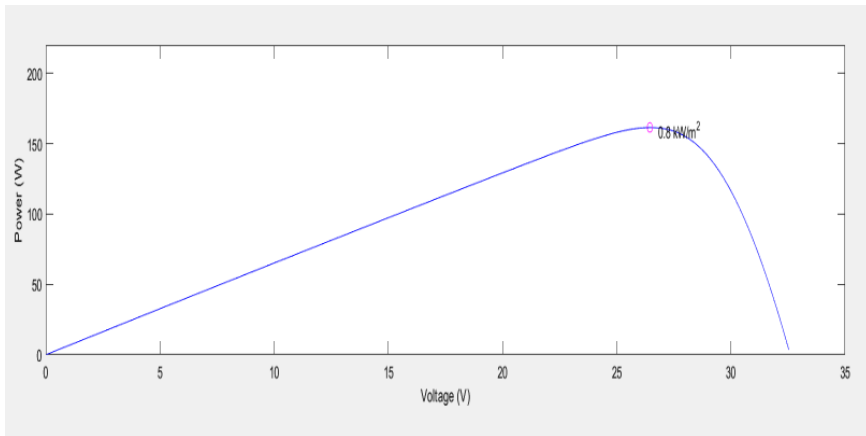

Figure8 :P-V Characteristics of Kyocera Panel

3.BOOST CONVERTER

A boost converter is a DC to DC power converter that steps up voltage from its input to its output. It is a step up converter. It has two modes of operation.

Modes of operation of Boost converter:

Model1:

The inductor is charged by the battery when the switch is closed, storing energy. This mode causes an exponential increase in inductor current. Due to the diode's ability to stop current flow, the load current, which is supplied by the discharge of the capacitor, remains constant.

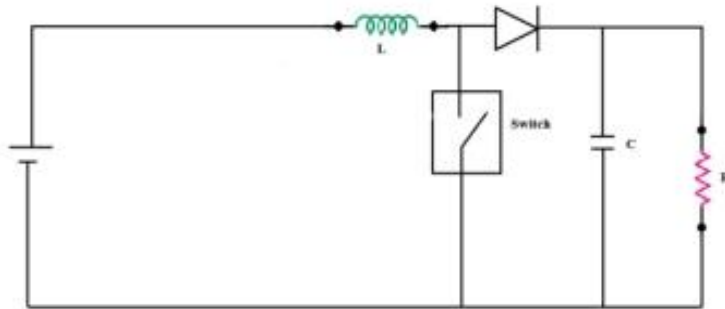

Figure9: mode 1 operation

Mode2:

The switch is open in mode 2, which causes the diode to short circuit. Through opposing polarities, the inductor's stored energy is discharged, charging the capacitor in the process. Throughout the entire process, the load current is constant.

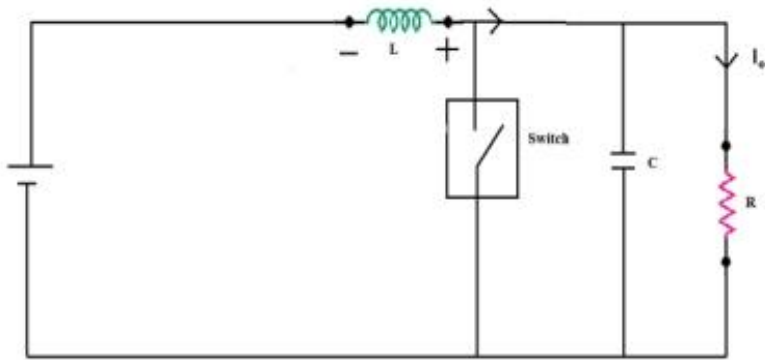

Figure 10: Mode 2 operation

Table 2. Elements specifications

Element	Specification
Inductor	5e-3
Diode	Forward voltage: -0.8v
Mosfet	Internal dioderesistance:0.01
Input capacitor	4000e-6
Output Capacitor	1e-6
R load	50 ohms
Battery	Li-Ion

4.RESULTS

The results of different algorithms are as shown:

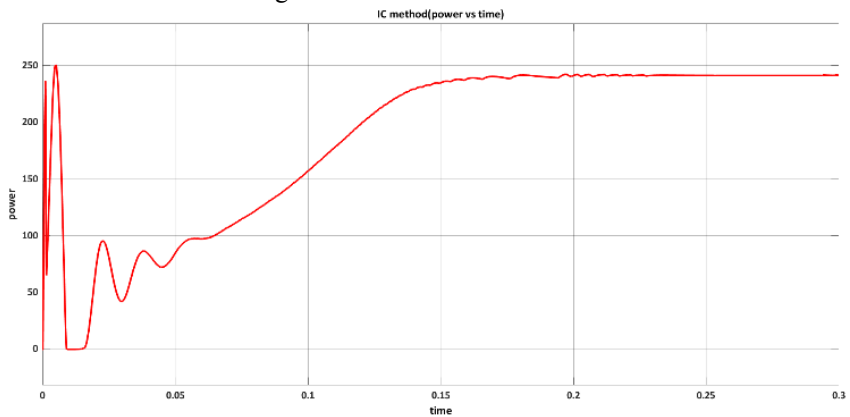

Figure 11. IC METHOD(Power vs Time)

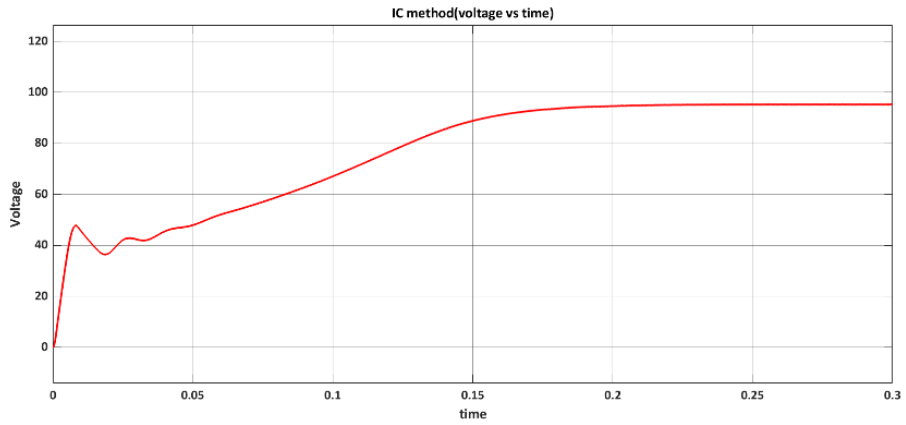

Figure12.IC METHOD(voltage vs Time)

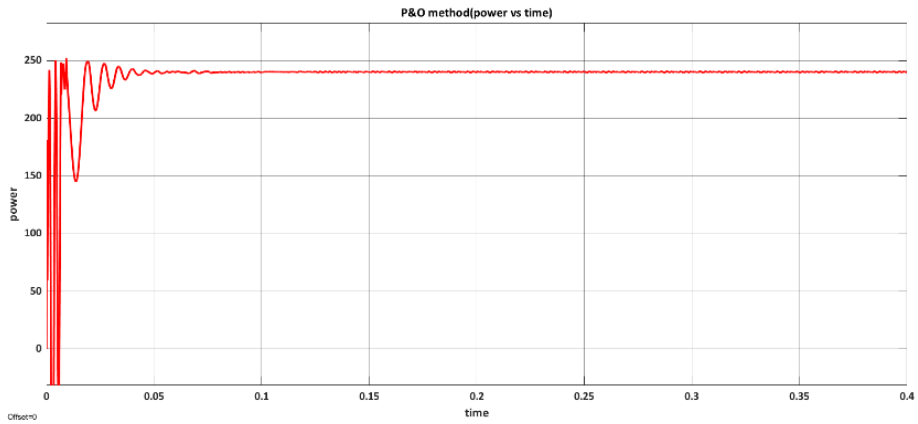

Figure 13.P&O METHOD(power vs Time)

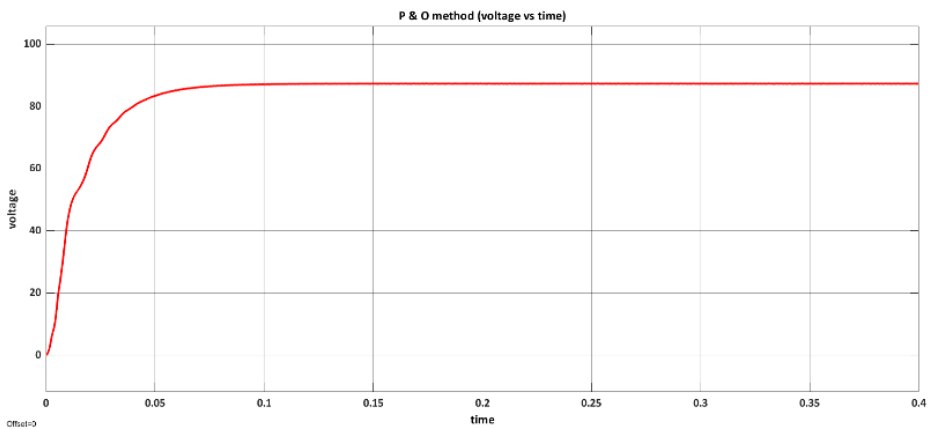

Figure 14.P&O METHOD(voltage vs Time)

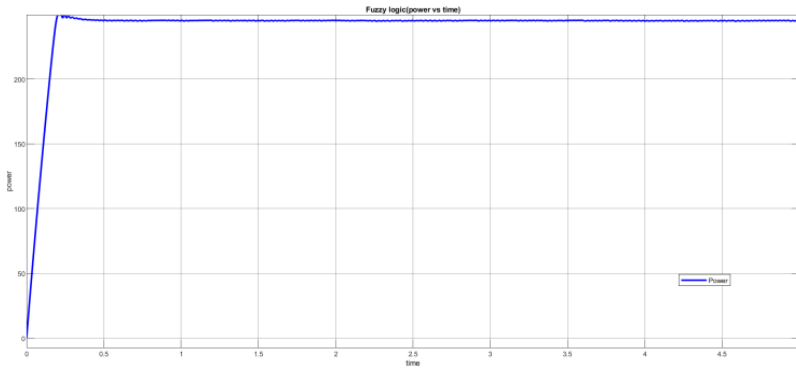

Figure 15.FUZZY LOGIC METHOD(power vs Time)

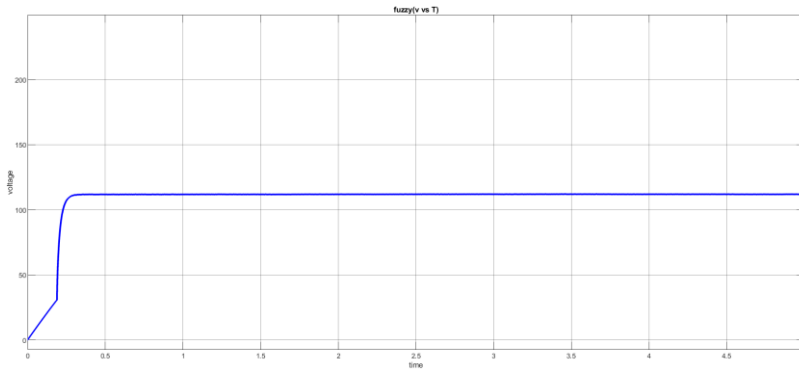

Figure 16.FUZZY LOGIC METHOD(voltage vs Time)

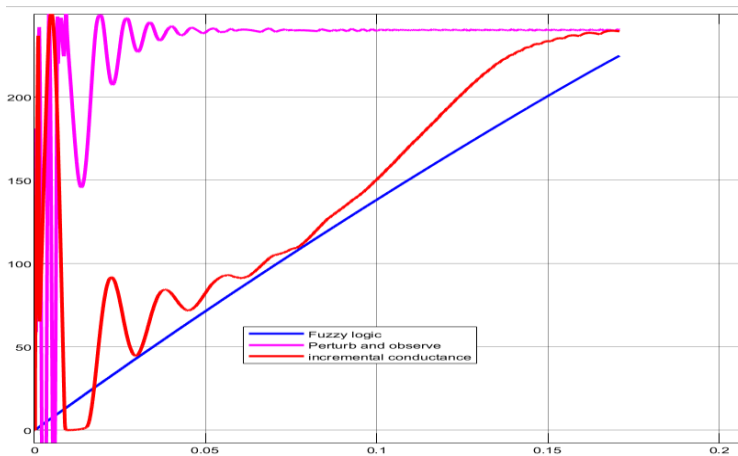

Figure17 .Comparison of power

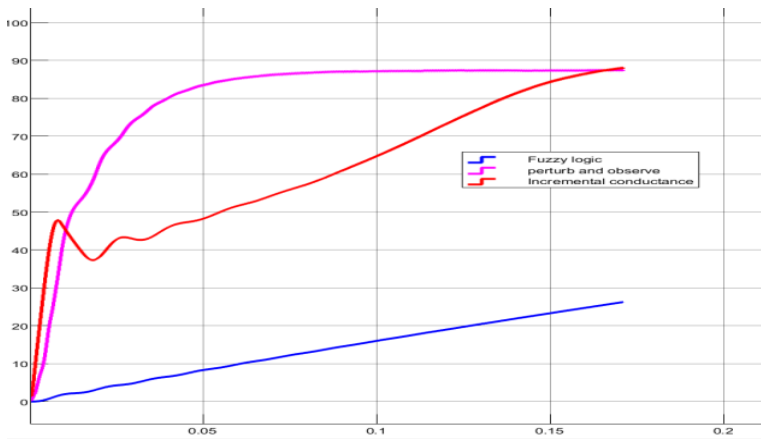

Figure18. Comparison of voltage

5.CONCLUSION

Perturb and observe controller is very easy to use and execute. At steady state, the system's operating point for the P&O algorithm oscillates about the MPP causes the available power to be wasted. The choice of the perturbation step-size is crucial since it affects how quickly the MPP is reached; a larger step-size can enable quicker tracking, but this will increase the oscillations around the MPP. While the amplitude of the oscillation can be slightly reduced using the InC method, which is more complicated than the P&O, the system might not function at the same level MPP. In comparison to the other MPPT algorithms examined in this research, the suggested fuzzy logic offers faster and more reliable tracking of maximum power.

References

1. Beriber, D., & Talha, A. (2013). "MPPT techniques for PV systems". 4th International Conference on Power Engineering, Energy and Electrical Drives. doi:10.1109/powereng.2013.6635826
2. Gergaud O, Multon B, Ben Ahmed H. "Analysis and experimental validation of various photovoltaic system models". 7th International ELECTRIMACS Congress, Montréal, Canada, 2002, pp. 1-6.
3. ESRAM T, Chapman P.L. "Comparison of photovoltaic array maximum power point tracking techniques". IEEE Trans. Energy Conversion, 2007; 22: 439-449.
4. Tafticht T, Agbossou K, Dombia ML, Chériti A. An improved maximum power point tracking method for photovoltaic systems. Renewable Energy, 2008; 33: 1508-1516.
5. Veerachary M, Senjyu T, Uezato K. "Neural-network-based maximum-power-point tracking of coupled inductor interleaved boost converters supplied PV system using fuzzy controller". IEEE Trans. Ind. Electron, 2003; 50: 749-758.
6. Enrique JM, Durán E, Sidrach-de-Cardona M, Andújar JM. "Theoretical assessment of the maximum power point tracking efficiency of photovoltaic facilities with different converter topologies". Solar Energy, 2007; 81: 31-38.
7. Femia N, Petrone G, Spagnolo G, Vitelli M. "Optimization of Perturb and Observe Maximum Power Point Tracking Method". IEEE Trans. Power Electron., 2005; 20: 963-973.