

# Design and Development of High Frequency Inverter for Wireless Power Transfer Application

*B Phaneendra Babu*<sup>1\*</sup>, *V Karthik*<sup>2</sup>, *Mohammed Musharraf*<sup>2</sup>, *Ahmed Hussein Alkhayyat*<sup>3</sup>, *Deepika Dua*<sup>4</sup>

<sup>1</sup> Gokaraju Rangaraju Institute of Engineering and Technology, Hyderabad, INDIA

<sup>2</sup> Computer Technical Engineering Department, College of Technical Engineering, The Islamic University, Najaf, Iraq

<sup>3</sup> Uttaranchal School of Computing Sciences, Uttaranchal University, Dehradun 248007 INDIA

**Abstract.** A number of power electronics converter topologies are implemented as Wireless Power Transfer (WPT) systems applications expand. In these applications, the optimal converter design is essential for handling the high power and frequency operation. In this paper, Simulation & Hardware development of High frequency Inverter with 90KHz frequency with Pulse Width Modulation switching strategy is presented. The inverter topology is simulated in 2021a version MATLAB/Simulink with R and RL loads and its conversion ability is proven through relevant waveforms. Simultaneously designed and developed prototype model of power rating 100watt with Mosfet as switches at output voltage of 230V with R load and analyse the output behaviour of voltage waveforms at various loads. The outcomes show effective enhancements for the proposed design.

**Keywords:** Wireless Power Transfer (WPT), High Frequency, Pulse width modulation

## 1 Introduction

The efficient transfer of electric power from one point to another across a vacuum or an environment without the need of wire or any other material is known as wireless power transmission (WPT). High frequency is necessary for many advantages. The use of high frequency in wireless power transfer allows for more efficient and precise transfer of energy, as well as potentially reducing interference and allowing for smaller size of the components. The higher frequency is the better choice when losses have to be reduced, size have to be minimized and the local heating has to be prevented. However, it's important to note that the specific frequency used for wireless power transfer depends on the specific application and requirements of the system, and other factors such as safety and regulatory requirements may also need to be considered. One of the most critical components of the WPT system is the HF inverter. There are many topologies of high frequency inverter. Among them H bridge are used in simulation and half bridge in prototype is used. Recent advancements in scientific

---

\* Corresponding author: [bobbaphani@gmail.com](mailto:bobbaphani@gmail.com)

and methodological techniques have led to the development of compact and portable electronics. Power electronics converters have become essential in modern electronic devices due to their critical functions, making them more practical and attractive. The growing popularity of Wireless-Power Transmission (WPT) systems in everyday life has increased the demand for smaller and more portable power electronics. The HF Inverter is used for the WPT application in this project, with a class-E inverter being the chosen converter. The use of a high-frequency switching frequency of 90 KHz reduces the size of circuit components, such as inductors and capacitors. The PWM method is employed for switching, as it is both simple and efficient, reducing switching pressure and electromagnetic interference (EMI). This project presents an optimal layout for a 1KW, 90 KHz 1-phase inverter for WPT devices with closed-loop configurations and detailed selection of electrical power and signal components. The proposed inverter is simulated in MATLAB/Simulink 2021a version, and its conversion ability is proven through relevant waveform and figure analysis. A prototype model of a power rating of 100 watts with MOSFET switches at an output voltage of 230 volts with a bulb load is designed and developed, and the output behaviour of voltage waveforms at various loads is analysed. The proposed design shows effective enhancements in conversion ability as One of the most critical components of the WPT system is the HF inverter. There are many topologies of high frequency inverter. Among them H-bridge are used in simulation and half bridge in prototype.

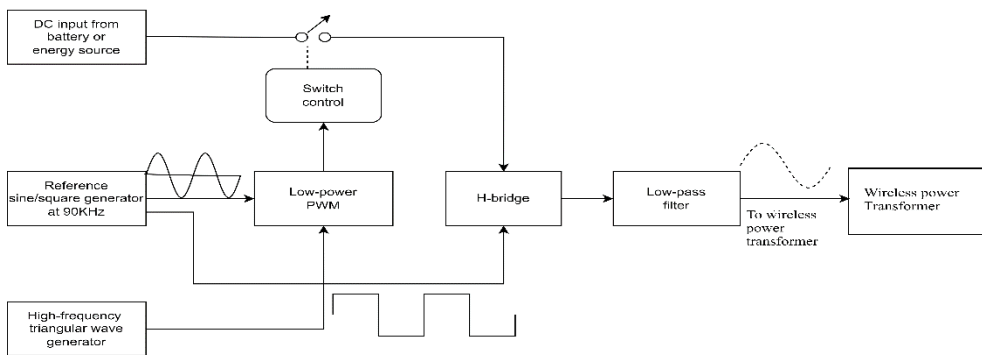

Fig 1 Block Diagram of High Frequency Inverter

Fig 1 Block Diagram of High Frequency Inverter shows the block diagram of the proposed model. DC input power supply is given from battery or SMPS, by comparing reference wave and triangular pulse PWM signal is generated which is used to pulse H bridge inverter or Mosfet switches at high frequency switching pulse to obtain high frequency output. Various filters or used to remove ripples and smoothen the output voltage waveform. In simulation we can generate High frequency pulse either directly or by comparing reference pulse using PI technique. In case hardware various electronic components are used to generate required pulse. In both cases for obtaining closed loop operation, we need feedback from output voltage and current. In MATLAB PI technique is used from voltage and current values compared with reference signal to generate PWM signal. Simultaneously in hardware model current and voltage readings are fractionized to produce required pulse using MSP controller and IC.

## **2. Proposed Design Procedure**

Typically, proposed inverter deliver 1KW Power at 230Volts and 90KHz frequency using four semiconductor power switches. Power MOSFET are preferred in WPT applications due to its positive temperature coefficient and high switching frequency as well as considerations related to the breakdown voltage requirements. The entire inverter design process is presented in this section.

### **2.1 Design of inverter using MATLAB**

Simulation of High frequency Inverter with open loop and closed loop topologies are designed using MATLAB/Simulink. The MATLAB simulations are shown in fig 2 and 4

#### *2.1.1 Open loop Configuration*

In open loop configuration there is no feedback path from output to input and PWM signal is directly generated and given to the Mosfet's as a switches of H bridge inverter. Fig.3 shows 1-phase HF inverter with the MOSFET. Ideal DC Voltage source supply of 100V is given to the switches input terminal. In this the pulse is generated directly through Pulse generator block and the duty cycle of 0.5 is assigned. Two switches open at alternative manner respectively to provide continuous supply to the load. Not logic is used to provide alternative pulses to the switches. End response of the switches is linked to RL load, simulated waveforms shown in the Fig.3

#### *2.1.2 Closed loop Configuration*

The In closed loop operation feedback from output is given to input along with reference signal such that it will correct if any error present in the output as compared with reference signal. Fig.4 shows single phase Closed loop HF Inverter with PI Regulator. Ideal DC Voltage source supply of 100V is given to the switches input terminal. RC filter is arranged to reduce ripples in dc source. Switching pulse to switches is generated by taking output voltage, current values i.e., feedback from the output and given to Sine wave Reference block which analyse and calculated error in the output parameters and predetermined values. The predetermined values can be varied according to the type of application. The voltage and current feedback with gain is integrated to generate reference signal which simultaneously compared with repeating sequence to generate final pulse to the switch. RL and RC filters are used to remove or filter out the ripple content from the output. Simulated output is shown in the Fig 6

#### *2.1.3 Simulation Results*

A Simulink model of the mentioned converter topology was developed in MATLAB Simulink version 2021a. The open loop and closed loop inverters are simulated and results are shown in the figures. The performance can be confirmed by exposing the inverter system varying various loads. Simulation results tells us that the regulator is capable of producing good end response electric voltage parameter.

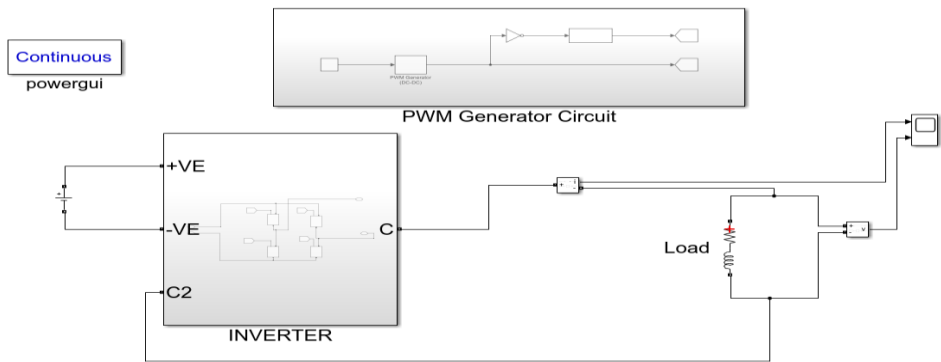

Fig 2 Openloop inverter simulation in MATLAB

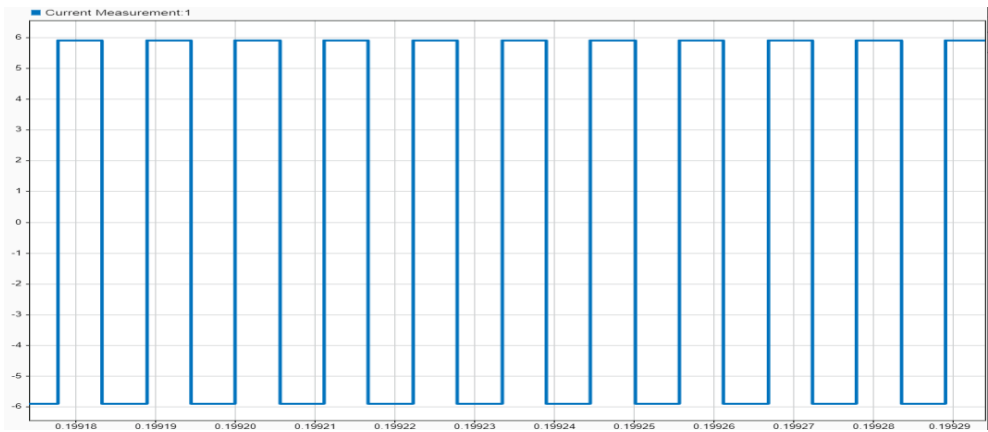

Fig 3 Output current waveform of open loop inverter



Fig 4 Output voltage waveform of open loop inverter

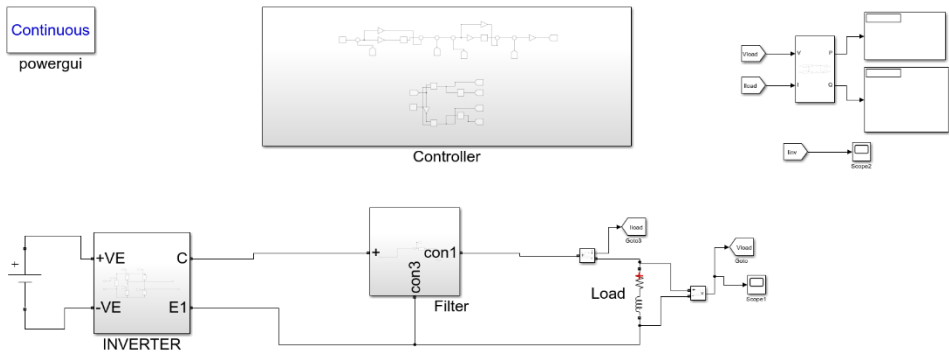

Fig 5 Closedloop inverter Simulation in MATLAB

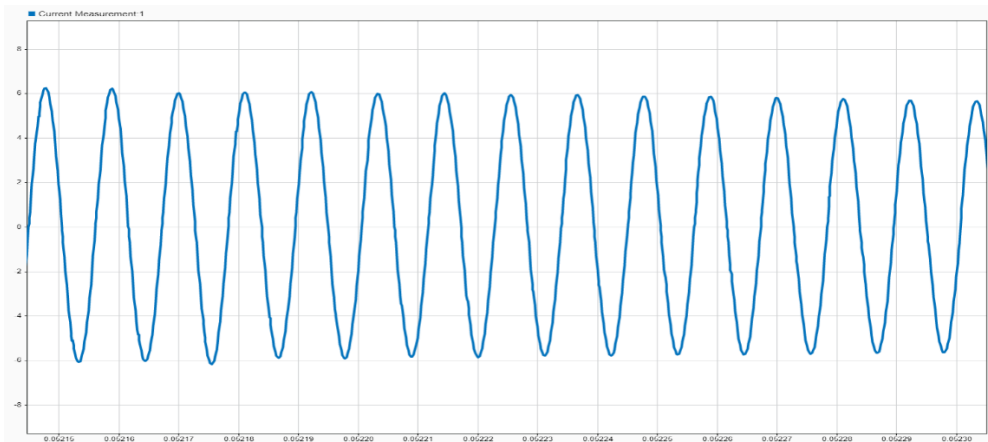

Fig 6 Output current waveform of closeloop inverter

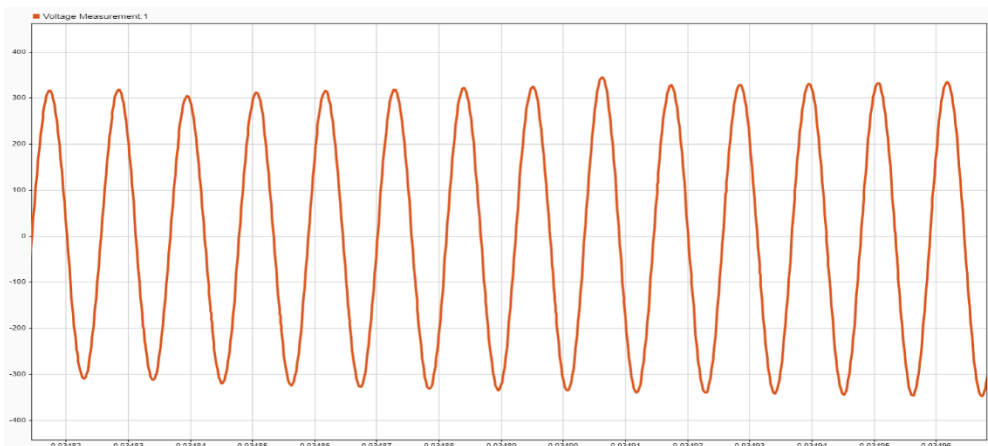

Fig 7 Output voltage waveform of closeloop inverter

### 3. Hardware system development

Due to some electronic constraints the Hardware ratings of the Inverter is reduced to 100Watt at an output of 230Volts and 30KHz frequency. Implementing a high-frequency inverter for wireless power transfer (WPT) applications requires careful consideration of several factors such as power requirements, efficiency, and electromagnetic interference (EMI). The first step is to determine the power requirements of application, such as the power output, input voltage, and frequency range. This will help you to select the appropriate components for high-frequency inverter. In this project requirements are 100watt 230volts 30KHz frequency. Then choosing the inverter topology and select the switching devices. The switching devices, such as MOSFETs or IGBTs, are critical components in the high-frequency inverter. Choose the devices that can handle the voltage and current requirements of your application and have fast switching speeds to reduce switching losses. In this MOSFETs used as switching devices with heat integrated sinks. Designing the control circuit is responsible for regulating the output voltage and frequency of the inverter. The control circuit must be designed to provide high accuracy and stability over a wide range of operating conditions. In this project we used MSP with SG3525PWM IC for controlling purpose. To optimize the efficiency, consider using high-quality components, minimizing the switching losses, and designing an efficient control algorithm. Once you have designed and implemented your high-frequency inverter, it is essential to test and validate its performance. Testing inverter under various operating conditions to ensure that it meets application requirements. Overall, implementing a high-frequency inverter for WPT applications requires careful consideration of several factors, including power requirements, efficiency, and EMI. The hardware design for the inverter including MSP microcontroller circuit, Inverter circuit and MOSFET driver. The system comprises of an opto isolator, gate drivers, an inverter circuit, a filter circuit, and a step-up transformer. PWM signal generated by MSP microcontroller should be isolated for safety. The gate drivers then fed the outputs. After that, power switches get the gate drivers' output. Because of the switching pattern, the inverter's output has a square waveform. The harmonic content was reduced using the LC filter to produce a square wave signal. The hardware design for the inverter including MSP microcontroller circuit, Inverter circuit and MOSFET driver. The system comprises of an opto isolator, gate drivers, an inverter circuit, a filter circuit, and a step-up transformer. PWM signal generated by MSP microcontroller should be isolated for safety. The gate drivers then fed the outputs. After that, power switches get the gate drivers' output. Because of the switching pattern, the inverter's output has a square waveform. The harmonic content was reduced using the LC filter to produce a sine wave signal.

#### 3.1 Block diagram of hardware system

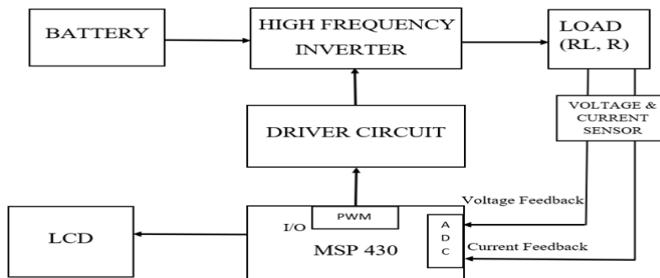

Fig 8 Hardware block diagram of High frequency Inverter

**Battery:** The battery will be a 12V, 1.3Ah/7.5Ah battery. From battery the dc power will be given to all the electronic devices.

**Inverter:** The inverter converts the battery's dc power to ac power. It will convert the dc voltage to an approximate 230V ,90KHz.

**Feedback:** Voltage and current sensors provide feedback from the load.

**MSP Controller:** It will take feedback from sensors and with comparison with reference value it will generate signal to driver circuit.

**Driver circuit:** It will generate PWM signal for Mosfet's gate terminals for switching the Mosfet.

**LCD Display:** It is 16x2 display which is used to display measured parameters.

**Load:** AC load will be a variable type resistive load i.e., Incandescent lamps

Table -1: List of components

S.NO	List of the components
1	IRFZ44N Mosfet
2	ZMPT101B AC Voltage Sensor
3	ZMCT103C 5Amp AC Current Sensor
4	DC-DC buck converter (12V to 5V)
5	SG3525 PWM Controller Module
6	MSP430G2553 Controller
7	PC817 opto-coupler
8	Arduino Nano
9	Battery (12V, 1.3Ah/7.5Ah)
10	Voltage level shifter (5V to 3.3V)
11	Transformer (12/230)
12	LCD Display (16x2)

#### 4. Hardware operation

When the switch is on at the battery then the inverter starts operating.12V DC supply is converted to 5V DC supply through LM25965 buck converter. The 5 volts supply is connected to various electronic components such as LCD display, voltage and current sensors, MSP and NANO controller which operate at 5volts DC supply. Simultaneously 12Volts supply is given to Inverter circuit as well as to centre tap Ferrite transformer. ACS712 current sensor and ZMPT103 voltage sensor measure the voltage and current values, the output of sensors is at 0-5volts depending upon their magnitude. Further it is given to Arduino nanos A0 and A1 pins which is used to convert Analogue signal to digital signal. D5 and D6 pins of nano is given to voltage level shifter which convert 5volts dc to 3.3volts dc as MSP take 3.3v input signal and finally connected to P1.0 and P1.1of MSP430 controller. The MSP controller is interconnected with LCD display which displays the measured value of current and voltage for monitoring all the data, simultaneously stabilises the given values with pre fractionized values to allow feedback provisions.

It will generate pulse signal depending upon the feedback values. The output from pin P2.4 and P1.6 of controller is given to Pic817 Optocoupler which is used to giving pulse to the PWM IC SG3525 through isolated terminals. On receiving signal to SG3525 pin Vcc and S0 it will generate PWM signal of high frequency which is given to IRFZ44N Mosfet gate terminals. Mosfet start conducting which will rectify DC to high frequency AC of 12volts in between filters are used to reduce noise of the signal AC voltage is stepped up using Ferrite core transformer from 12V to 230volts. The output of the transformer is connected to load terminals which is 100watt bulb and cycle of feedback will continues.

#### 4.1 Results and discussions

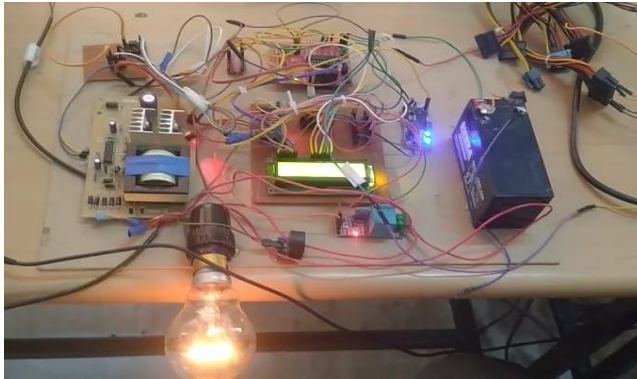

Fig 9 Working of hardware model

Developed prototype model of High frequency inverter with 100watt ratings with electric components as described in the description. DC Input from the 12volts battery is converted into 230volts AC at approximately 30KHz frequency. Buck converter supply 5V constant DC supply to all the electronic components throughout the operation. Current and Voltage sensor provide continuous feedback from load. MSP430G2553 controller take feedback from sensors and with comparison with reference value it will generate signal to driver circuit and also interconnected with LCD circuit. PWM IC SG3525 generate switching pulses to IRFZ44N Mosfet. These are integrated with Aluminium heatsinks to cool and maintain constant temperature throughout the operation. Terminals are taken from output of Mosfet and Transformer to measure the electric parameters. The output voltage waveform and frequency are measured through DSO and results are depicted in the fig.8. The designed inverter maintains constant voltage throughout the operation due to feedback mechanism. Measured values of electric quantities monitor through LCD display continuously and changes in output electric quantities can easily observed. Due to few electronic constrains the designed inverter deliver 100watt output at 230V AC and approximately at 30KHz frequency. Fig.9 shows the prototype working model of inverter and fig.8 shows the output voltage waveform of inverter.



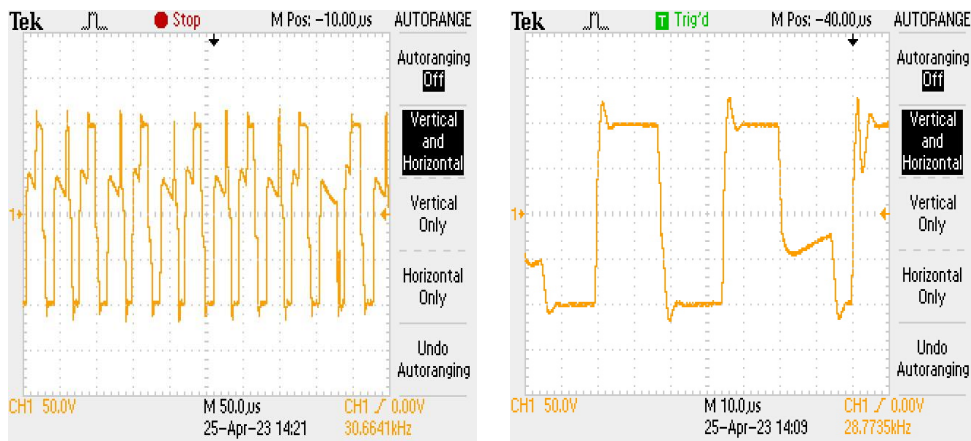

Fig 10 Output voltage waveforms of inverter in DSO

The output waveforms in the fig.10 shows the output voltage waveform and frequency across the load. The output square waveform with harmonic content depicted across the load.

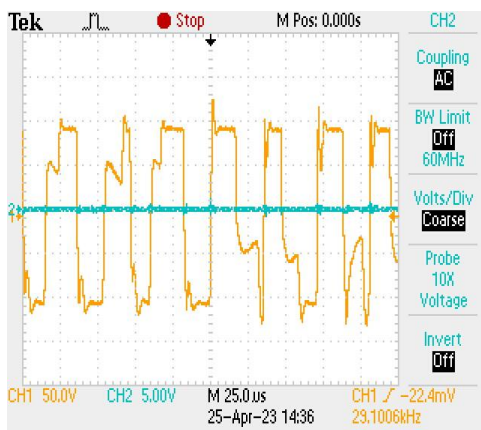

Fig 11 Input DC voltage and Output AC voltage waveform in DSO

Fig.11 shows the both Input DC voltage and Output AC voltage waveform. DC input of 12V shown in channel two output and AC output in channel one output of DSO. The output waveform with various load is analysed and measured to demonstrate Inverter capability during operation. Simulation output waveforms and result are compared with Hardware results and output waveforms which shows similarities simultaneously

## 5. Conclusion

The paper presents an effective design and implementation of High Frequency Inverter for WPT applications in MATLAB/Simulink at 1KW,230V and 90KHz frequency with open and closed loop operations. Simultaneously hardware model at 100watt,230V and 30KHz frequency with feedback. Results demonstrates that the inverter is capable of producing desired output due to the feedback which makes the system more stable and reliable in operation. Performance of the planned inverter design is evaluated under various operating and control circumstances. The output parameters of the inverter depict that it is suitable for WPT applications.

## References

1. S. M. Cherati1, N. A. Azli2, S. M. Ayob and A. Mortezaei “Design of a Current Mode PI Controller for a Single-phase PWM Inverter” 2011 IEEE Applied Power Electronics Colloquium (IAPEC)
2. Ahmed A. S. Mohamed, Dual Allen, Tarek Youssefi “Optimal Design of High Frequency H-Bridge Inverter for Wireless Power Transfer Systems in EV Applications”. IEEE, and Osama Mohammed, Fellow, IEEE Energy Systems Research Laboratory, Florida International University
3. Singh, S.K., Tambe, S.P., Raja, V.S., Kumar, D., Thermally sprayable polyethylene coatings for marine environment, *Progress in Organic Coatings*, 2007, 60(3), pp. 186–193.
4. Siva Subramaniyam C N1, Lokeshwar S2 “Design of Single-Phase High Frequency Inverter for Wireless Charging Application”. *International Research Journal of Engineering and Technology (IRJET)* e-ISSN: 2395-0056 Volume: **06** Issue: 05 May 2019 [www.irjet.net](http://www.irjet.net) p-ISSN: 2395-0072
5. Chandrakant R Shinde1, Gopal R Shinde “Inverter design using high frequency”. Vol-3 Issue-1 (2017) *IJARIE-ISSN(O)-2395-4396*
6. Supritha S B, Sushmitha P C, Ujwala Kini H, Vidya M, Dr. Rajendra R. Patil “Wireless Power Transfer By High Frequency Resonating Coils And Mosfet”. *International Journal of Engineering Research & Technology (IJERT)* ISSN: 2278-0181 Published by, [www.ijert.org](http://www.ijert.org) NCESC - 2018 Conference Proceedings
7. Nimitha Gopinath1, Praveen Kumar C2”Matlab/Simulink Model of High Frequency Converter For Electrosurgical Generators”. *IOSR Journal of Electrical and Electronics Engineering (IOSR-JEEE)* e-ISSN: 2278-1676, p-ISSN: 2320-3331, Volume **13**, Issue 2 Ver. III (Mar. – Apr. 2018), PP 29-35
8. Suresh Kumar Tummala, Phaneendra Babu Bobba & Kosaraju Satyanarayana (2022) SEM & EDAX analysis of super capacitor, *Advances in Materials and Processing Technologies*, 8:sup4, 2398-2409,
9. Tummala, S.K., Indira Priyadarshini, T., Morphological Operations and Histogram Analysis of SEM Images using Python, *Indian Journal of Engineering and Materials Sciences*, 2022, 29(6), pp. 794–798.
10. Satyanarayana, K., Gopal, A.V., Babu, P.B., Design optimisation of machining parameters for turning titanium alloys with taguchi-grey method, *International Journal of Machining and Machinability of Materials*, 2013, 13(2-3), pp. 191–202
11. Kosaraju, S., Anne, V.G. & Popuri, B.B. Online tool condition monitoring in turning titanium (grade 5) using acoustic emission: modeling. *Int J Adv Manuf Technol* 67, 1947–1954 (2013).
12. Naik, R.B., Ratna, D., Singh, S.K., Synthesis and characterization of novel hyperbranched alkyd and isocyanate trimer based high solid polyurethane coatings, *Progress in Organic Coatings*, 2014, 77(2), pp. 369–379
13. Sachin Maheshri1, Prabodh Khampariya “Simulation & Hardware Development of Single-Phase Sinusoidal Pulse Width Modulation (Unipolar) Inverter” *International Journal on Recent Technologies in Mechanical and Electrical Engineering (IJRMEE)* ISSN: 2349-7947 Volume: **2** Issue: 3 001–007