

Improving the quality of irrigation water by vacuum treatment

A I Belyaev^{1*}, *E P Borovoy*², *A M Pugacheva*¹, *O N Volskaya*³, and *Yu N Petrov*¹

¹Federal Research Center for Agroecology of the Russian Academy of Sciences, Russia

²Volgograd Agrarian University, Volgograd, Russia

³Volgograd State Technical University, Volgograd, Russia

Abstract. The first stage of research of the water purification plant was carried out in laboratory conditions on a hydraulic model at the Department of Water Supply of the Volga State University, the second stage of tests for purification and activation of water was carried out at the experimental production site of the Volga State University "Innovative Village" before sowing tomatoes in the ground, on a plant with a capacity of 10 m³/ day. The second stage included the work performed in the following sequence: first, they achieved stable operation of the water purification unit by vacuum-ejection method, then they achieved stable operation of the water activation unit using a vacuum activator. The final tests were carried out at the start of both installations. The installations worked in semi-automatic mode. It should be noted that the vacuum-ejection unit includes a vacuum-ejection oxidizer and a semi-automatic sand filter, working as a single unit.

1 Introduction

According to Doctor of Technical Sciences, Grigorov S.M.: "Water-ecological balance in irrigation systems will take place if the water intake for irrigation from water sources during the extremely dry periods of the growing season does not exceed the established sanitary norm, and irrigation does not result in formation of an erosive runoff, undesirable change in the natural regime of groundwater and adverse changes in the water-salt regime of irrigated areas and adjacent territories. Restrictions on the norms of withdrawal of natural waters from water sources and norms of water supply are known [1]. All of them aim to preserve the water-ecological balance characteristic of automorphic soil formation in irrigated areas, as well as not disturbing the natural ecological situation that had developed before the start of irrigation in the adjacent territories. Irrigation water quality indicators can be attributed to the standards for the functioning of irrigation systems, which characterize the water-ecological balance" [7].

Scientists have been dealing with irrigation water quality issues for many years [4-6]. The authors have also dealt with this problem for more than a decade. They have developed an effective scheme for groundwater treatment with its simultaneous activation for drip

* Corresponding author: aksenovmp@mail.ru

irrigation. The studies carried out according to the above scheme, as well as the studies of many scientists, aimed to develop a method and devices for activating and treating groundwater for drip irrigation, which will significantly increase the yield and quality characteristics of cultivated crops at the lowest energy costs, safety and ease of maintenance. them [1].

2 Materials and methods

The test area is a drip irrigation system at the pilot production site of the VolgSAU "Innovative Village" with preliminary laboratory studies of the water treatment plant model.

The research is based on the introduction of two methods of water treatment: the first is vacuum ejection, the second is vacuum activation. Both installations are related to reclamation, specifically to installations for the implementation of reclamation measures: irrigation with simultaneous activation of water to obtain high yields and high-quality crop production. To analyze the positive impact of activated water on the growth, yield and quality of tomatoes, the authors decided to divide the irrigated plot into 2 plots. Irrigation of tomatoes in the first area was carried out with plain water from a well, and in the second area - according to the developed scheme (Figure 1).

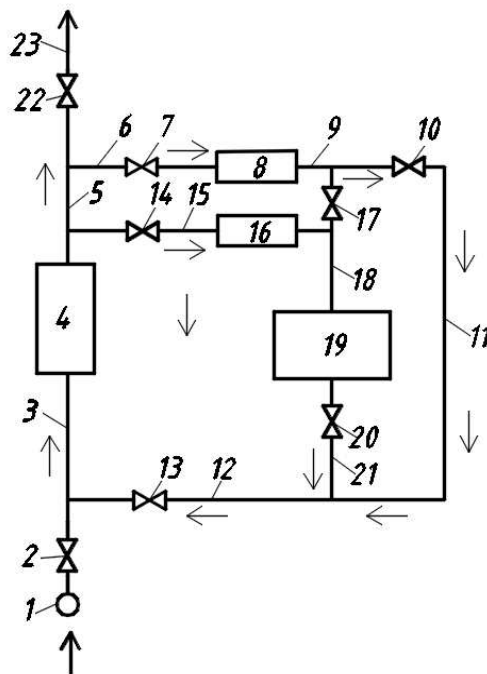

Fig. 1. Diagram of underground water purification and activation plants.

The complex of devices and equipment shown in the diagram (Figure 1) consisted of a pump 4, which was connected by a suction pipeline 3 through a valve 2 to a well 1 and a carrier pipeline 5 through a valve 22 to a line connecting to the drip irrigation system of the site. Vacuum-ejection unit 8, designed to purify underground water from suspensions, iron and other impurities, vacuum activator 16, designed to activate water, circulation tank 19 are connected in series by pipelines 6, 9, 11, 12, 15, 18, 21 through valves 7, 10, 13, 14, 17,

20. The circuit works as follows. Groundwater from well 1 is supplied through suction pipeline 3 through open valve 2 to pump 4 and then through pressure pipeline 6 through open valve 7 to vacuum ejection unit 8. In this case, valves 13, 14, 10, 20 are closed, valve 17 is open. In this mode, water, after cleaning from suspensions, iron and other impurities through an open valve 17, is fed into the circulation tank 19, where it is filled. When the tank is filled with water (according to the values of the flow meters or the threshold of water in the tank 19), pump 4 is automatically turned off, while valves 2 and 6 are closed, valves 14 and 20 open, which turns on the pump and purified water flows through the contour of positions 20, 21, 12, 13, 3, 4, 14, 15 enters the degasser 16. In this case, the valves 2, 7, 17 are closed. In the degasser 16, water is activated and circulates along the circuit 16, 18, 19, 20, 21, 12, 13, 3, 4, 14, 15, 16, 18, 19 "up to the optical density $D = 0.09 - 0.12$, as the main indicator of cavitation processes, determined on the turbidimetric liquid analyzer AZhST-94. During the study of activated water, the heating temperature $^{\circ}\text{C}$, water acidity - pH, and total water hardness were additionally determined" [7]. As soon as the activated water reached the indicated optical density, within an hour, this water was supplied to the drip irrigation system for watering tomatoes. Moreover, the watering of tomatoes was alternated, i.e. the first irrigation was carried out with purified water along the circuit 3, 4, 5, 6, 7, 8, 9, 10, 11, 12, 13, 3, 4, 22, 23, the second with activated water along the circuit 3, 4, 14, 15, 16, 18, 19, 20, 21, 12, 13, 3, 4, 22, 23. The process of purification from suspensions, iron, and other impurities was carried out on a vacuum ejection unit 8, shown in fig. 2 and includes a vacuum ejection oxidizer 1' and a sand filter with elements 4', 5', 6', 7', 8', 9', 10', 11', 12', 13', 14', 15', 16'. Installation of water treatment 8 operates as follows. The water supplied from the well 1 through the suction pipeline 3 through the open valve 2 to the pump 4, and then through the pressure pipelines 5 and 6 through the open valve 7 enters the vacuum ejection treatment plant 8. In this case, the valves 13, 14, 17 are closed. Vacuum-ejection oxidizer 1', mounted on a sand filter 3', consists of a confuser 12, a Venturi nozzle 22, and several stages connected coaxially one into another 32, 42, 52, and 62.

3 Results and Discussion

The essence of the work of the vacuum ejection oxidizer 1' is described in detail in the monograph of the authors [2] and consists in the fact that the installation operates under pressure and in the places of narrowing of its elements 1² and 2² "vacuum zones are created that allow gases dissolved in water to boil in volume, destroy the integrity jet and turn it into a water-air flow that fills the entire cross-sectional area of the vacuum chamber 3². The released gases in the vacuum annular zone are sucked off by the flow itself. The release of CO₂ contributes to an increase in the pH of the water, which creates favorable conditions for the oxidation of iron. The water-air flow obtained in this way enters the vacuum-ejection stages 4², 5² and 6², in which air is ejected from the environment through the air supply pipes 72, due to which the process of continuous dispersion of water droplets in the ejected air flow takes place" [2]. Further, the water-air flow enters the flow divider, where an intensive separation of gases and water occurs. The gases exit into the atmosphere through baffles arranged on the pipe 2'.

Water after the vacuum ejection oxidizer 1' enters the semi-automatic downward filtration filter, the essential advantage of which is the absence of the need for a tank and pumps for wash water, which makes maintenance of the installation simple and does not require highly qualified specialists [10].

The filtering load is quartz sand of a standard equivalent diameter. Vacuum ejection oxidizer and filter work as a single mechanism. Its essence lies in the fact that, having passed the vacuum ejection oxidizer 1', water with oxidized iron, but already without gases,

enters the sand filter 3'. "Passing through an unflooded filter bed, water is freed from ferric iron, organic substances and suspensions" [2, 9].

After cleaning, the water initially goes to fill the circulation tank 19, which accumulates the volume of water for the activation process and further watering the tomatoes for several hours.

Purified water is activated using a vacuum activator 16 (Figure 1).

Vacuum activator 16 operates as follows. Water under pressure enters through the connecting pipe 1'' and then into the confuser 2'' with a Venturi pipe attached at the end into the vacuum chamber 3'' (Figure 2). "The gas emulsion flow formed at the chamber outlet is fed into a closed conical zone 4'' at an angle to its axis, thereby creating a rotational and translational motion for the flow. The flow begins to form a spiral vortex with a vertical axis and a vortex swirl radius decreasing downwards. force, the flow is divided into liquid and gas phases. At the same time, there is a deep separation and separation of aggressive gases from the flow, which are directed upwards and exit into the atmosphere through the branch pipe 6'', and the water purified from gases, which has changed its structure, is directed to the branch pipe 5'' and further into the drip irrigation system of the site" [2].

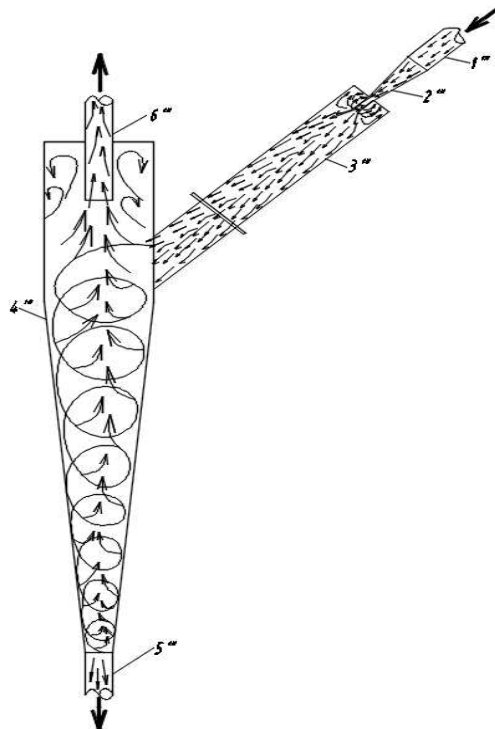

Fig. 2. Vacuum activator.

It should be noted that the purification and activation of irrigation water according to the proposed drip irrigation scheme made it possible not only to increase the yield, but also to improve the change in the chemical composition of tomato fruits. The studies were carried out on two areas identical in area and distribution of droppers, with the only difference being that one area was watered with plain water, the second - with purified and activated water. Moreover, watering with activated water was carried out as follows:

- During the flowering period - 3 times.
- Fruit formation - 3 times.

- Milky ripeness - 2 times.
- Full ripeness - 1 time.

All other irrigations on the experimental site were carried out with purified water. At the end of each interphase period, the maximum leaf area was determined in both plots [3]. The results are summarized in Table 1.

Table 1. The dynamics of the growth of the leaf surface of tomatoes when irrigated with plain and activated water in the interphase periods.

No. p/p	Interphase period, thousand, m ² /ha	Control (plain water)	Experience (activated water)
1.	Bloom	15.4	22.2
2.	Fruit formation	32.6	41.8
3.	Milky ripeness	29.8	42.0
4.	Full ripeness	18.0	24.5

At the end of the period of full ripeness, the quality of tomato fruits taken from both plots of 100 kg from different plots was compared. The results are summarized in Table. 2.

Table 2. Comparison of quality indicators of tomato fruits when irrigated with plain and activated water.

No. p/p	Chemical composition of tomatoes (fresh weight)	Control (plain water) at a yield of 55.0 t/ha	Experience (activated water) with a yield of 90.8 t/ha
1.	Organic and mineral compounds without water (dry matter), %	5.8	6.6
2.	Sucrose, %	3.8	3.3
3.	Vitamin C, mg/100 g	15.6	16.8
4.	Chemicals (nitrates), mg/kg	74.8	34.6

4 Conclusion

The studies carried out by the authors showed a close relationship between the yield and its quality (Table 2). When irrigated with plain water, the yield of tomatoes was 55.0 t/ha, and when irrigated with purified and activated water - 90.8 t/ha. The yield of activated water is 1.65 times higher than that of plain water. At the same time, the quality of the chemical composition is higher in terms of the main indicators for tomatoes watered with activated water than for tomatoes watered with plain water. Purified water by the vacuum-ejection method presented by the authors kills pathogenic bacteria. Activated water obtained by a vacuum method also has antibacterial properties. That is why irrigation water obtained using a vacuum is able to fight nitrates, and this is clearly seen from Table. 2. The content of nitrates in tomatoes watered with purified or activated water is 2 times less than in tomatoes watered with plain water.

References

1. A.D.O. Akhmedov, E.E. Dzhamaletdinova, *Features of water-saving technology for irrigation of vegetable crops in the south of Russia*, Scientific journal of the Russian Research Institute of Land Reclamation Problems, **4, 36**, 17-30 (2019)

2. E.P. Borovoy, O.N. Volskaya, A.A. Churakov, Improvement of groundwater treatment and activation technologies for effective use in the domestic and drinking water supply system (VolgGTU, Volgograd, 2020), 100
3. V.N. Kavtsevich, A.V. Derevinsky, *Evaluation of the components of the productive and biochemical composition of fruits in F1 hybrids obtained on the basis of racemes of tomato*, Bulletin of the Belarusian State Polytechnic University named after M. Tank, **1**, **47**, 22-27 (2016)
4. A.A. Sukhova, D.P. Arkova, E.A. Antyasolva, D.N. Nikiforova, D.R. Safina, Ameliorative complexes: assessment, state control and process management using digital technologies (Volgograd), 32 (2022)
5. E.I. Mikhnevich, D.E. Propolsky, *Analysis of water deironing methods and conditions for their application*, Reclamation, **2**, **80**, 59-65 (2017)
6. I.V. Novikova, E.N. Luneva, A.V. Gritsai, *Means and technologies of water treatment for drip irrigation of agricultural lands*, Scientific journal of the Russian Research Institute of Land Reclamation Problems, **3**, **35**, 1-17 (2019)
7. A.S. Ovchinnikov, V.S. Bocharnikov, O.V. Bocharnikova, E.V. Pustovalov, M.A. Denisova, *Analysis of the efficiency of filter media during iron removal of water from underground water sources for drip irrigation systems*, Izvestiya NV AUK, **2**, **62**, 330-338 (2021)
8. A.V. Loiko, I.V. Shibanov, G.G. Kagramanov, A.M. Blanco-Pedrekhon, *Experience in the implementation of membrane technology for the treatment of artesian waters with a high content of iron and manganese*, Vodoochistka, Water treatment, Water supply, **4**, **124**, 58-62 (2018)
9. P.D. Fraser, M. Truesdale, C.R. Bird, *Carotenoid biosynthesis during tomato fruit development*, Plant Physiol, **105**, 405-413 (2014)
10. A. Matsak, K. Tsytlshvili, *Using different filter media of stormwater treatment performance*, Norwegian Journal of development of the International Science, **1**, **20**, 19-22 (2018)
11. I.P. Kruzhilin, A.S. Ovchinnikov, N.V. Kuznetsova, O.V. Kozinskaya, S.D. Fomin, V.S. Bocharnikov, E.S. Vorontsova, *Water pressure monitoring in irrigation piping as quality management tools of sprinkler irrigation*, ARPN Journal of Engineering and Applied Sciences Open access, **13**, 4181-4184 (2018).